

Job Name: 25-3452 - Churchill Downs Skye Terrace Improvements  
 Job Location: Louisville, KY 40208  
 Contractor: Louisville Paving and Construction

Plant: 100  
 4/30/2026 1:21:58 PM

Tech: Jared - F  
 PC: J. Jarvis



**Structure ID: S215**

**P1 MH048BAVF**

**MH BASE Custom Ht T/n**

- P3) 32" x 32" - CASTING HEIGHT - 3"
- P2) 48" - MH FLAT TOP w/32"x32" Hole F/G - 12"
- P1) 48" - MH BASE Custom Ht T/n - 34"
- 1) CASTING - HOE 595 F/G
- 1) 48" - Conseal CS-102 1.00"
- 1) 32" x 32" - Conseal CS-102 1.00"
- 2) Hole - 16

0 lb  
 1629 lb  
 3534 lb  
 376 lb  
 0 lb  
 0 lb  
 0 lb  
 -----  
 Structure Total: 5539 lb

**Structure Notes:**  
 1. PER ASTM C478 SPECIFICATIONS.  
 2. CONCRETE = 4,000 PSI AT 28 DAYS.  
 3. NO STEPS AND NO INVERT CHANNEL.  
 4. CASTING BY ICAST (HOE 595 F/G)

REINFORCING PER ASTM A615 (GRADE 60).  
 - TOP SLAB (As .62) #5 BARS AT 6" C.C.E.W..  
 - RISER/WALLS (As .12)  
 - FLOOR (As .31) #5 BARS AT 12" C.C.E.W.

Rim: 454.5' Rim to Invert: 4.12' Slack: 0.44" Sump: 0" Step Position:

Position	Elev	Angle	Ext. (cw)	Pipe	Pipe OD	Connector	Hole	Horz Size	Up ( )	Offset
Invert 1	450.38'	0°	0"	12" HDPE	14.5"	Hole 16	16"	16.312"	-1.25"	0"
Invert 2	450.38'	252°	127.5"	12" HDPE	14.5"	Hole 16	16"	16.312"	-1.25"	0"
Invert 3										
Invert 4										
Invert 5										
Invert 6										
Invert 7										
Invert 8										

RIGHT-SIDE UP VIEW (int. dimensions)

UPSIDE-DOWN VIEW (int. dimenions)

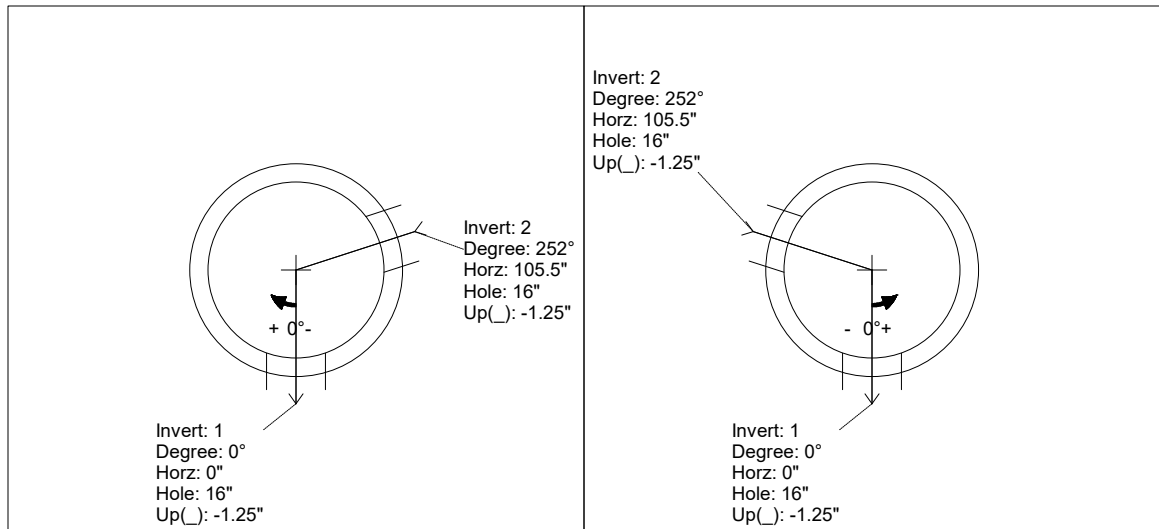
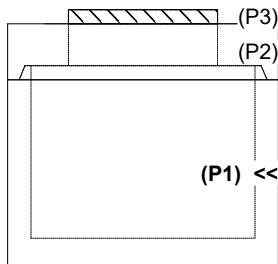

INSIDE WALL DIMENSIONS

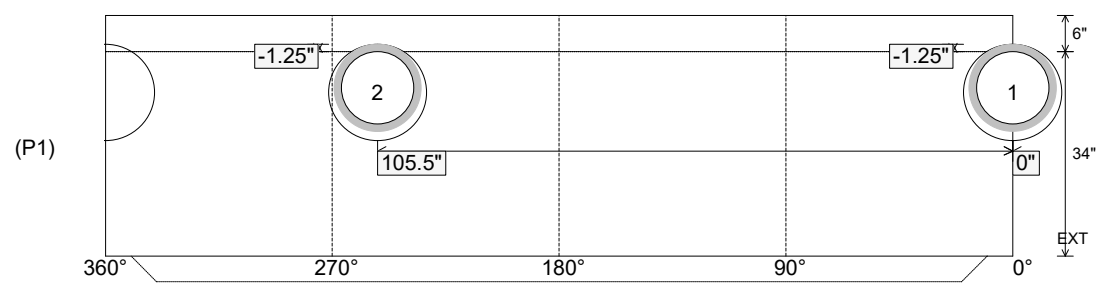

Coating (Int): Coating (Ext):	Seam Up: Tongue Seam Dn: n/a	Wall Thickness: 5" Floor Height: 6"	Height (Int): 34" Height (Ext): 40"	Weight (Net): 3534 lb Volume (Net): 0.9cu.yd
----------------------------------	---------------------------------	--	--	---