

Job Name: 25-1684P11 KYTC Jefferson Co. Call 200 (251007)
 Job Location: I-264 Louisville, Ky.
 Contractor: Cleary Construction, Inc.

Plant: Beaver Dam, Ky.
 5/28/2026 1:40:12 PM

Tech: N. Richards
 PC: J. Jarvis



Structure ID: 10+27 RT MH-A INLET 45A

P1 MH048BAVF

MH BASE Custom Ht

- P3) 24" - CASTING HEIGHT - 8"
- P2) 48" - ECC CONE w/ 24" HOLE - 36"
- P1) 48" - MH BASE Custom Ht - 40"
- 1) 48" - Conseal CS-102 1.00"
- 1) 24" - Conseal CS-102 1.00"
- 2) Hole - 30
- 1) Hole - 22
- 6) MH Step ML-10-TDS-NCR - 10"

0 lb
 3000 lb
 3328 lb
 0 lb
 0 lb
 0 lb
 0 lb
 0 lb
 Structure Total: 6328 lb

Structure Notes:
 -KYTC STATE PROJECT 251007
 -REINFORCING: PER ASTM C-478 SPECIFICATIONS.
 -TYPE 2 MANHOLE FRAME & COVER (BY OTHERS).
 -CS-102 BUTYL REQUIRED (SUPPLIED BY ICAST).
 -KYTC CERTIFICATIONS REQUIRED.

Rim: 581.24' Rim to Invert: 6.64' Slack: 0.18" Sump: 4.5" Step Position: 270

Position	Elev	Angle	Ext. (cw)	Pipe	Pipe OD	Connector	Hole	Horz Size	Up ()	Offset
Invert 1	574.6'	0°	0"	21" RCP B WALL	26.5"	Hole 30	30"	32.406"	0"	0"
Invert 2	574.6'	97°	49.096"	18" CMP	19"	Hole 22	22"	22.854"	2.5"	0"
Invert 3	574.6'	180°	91.106"	21" RCP B WALL	26.5"	Hole 30	30"	32.406"	0"	0"
Invert 4										
Invert 5										
Invert 6										
Invert 7										
Invert 8										

RIGHT-SIDE UP VIEW (int. dimensions)

UPSIDE-DOWN VIEW (int. dimensions)

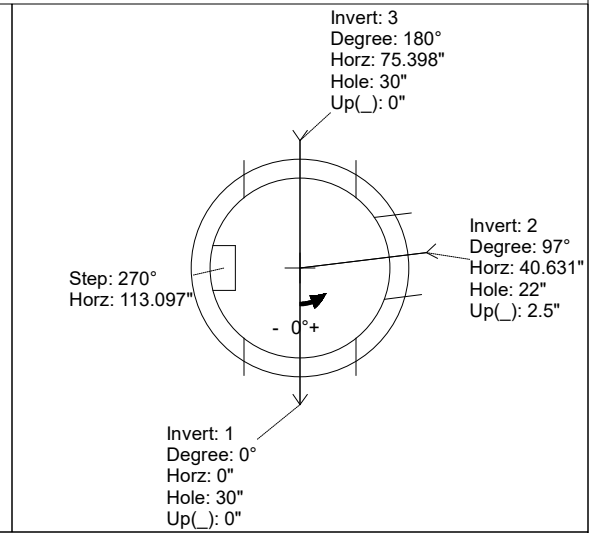
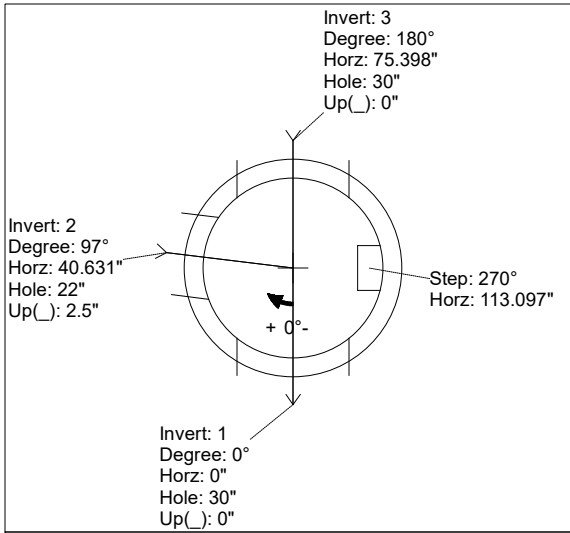
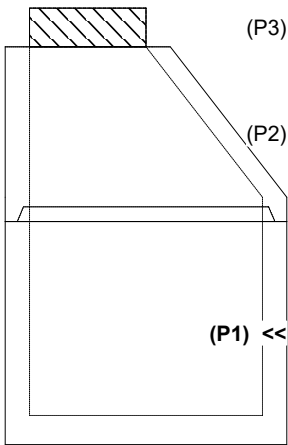

INSIDE WALL DIMENSIONS

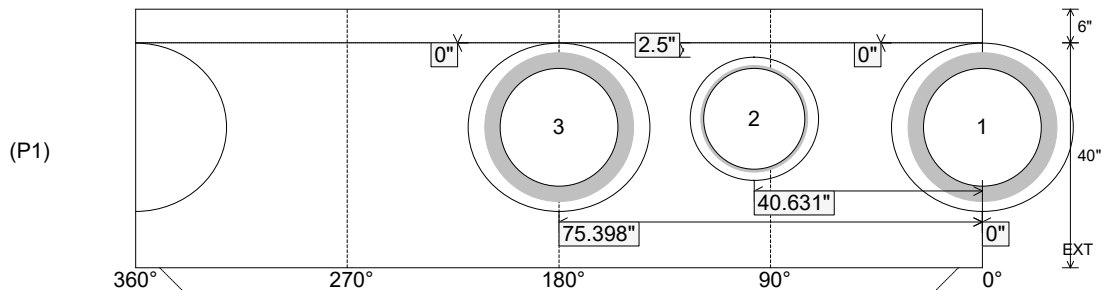

Coating (Int):
 Coating (Ext):

Seam Up: Tongue
 Seam Dn: n/a

Wall Thickness: 5"
 Floor Height: 6"

Height (Int): 40"
 Height (Ext): 46"

Weight (Net): 3328 lb
 Volume (Net): 0.85cu.yd