

Job Name: 26-1228 - L&N Federal Credit Union
 Job Location: Louisville, KY 40243
 Contractor: H & W Landworks

Plant: 100

5/6/2026 12:05:51 PM

Tech: Jared - A

PC: T. Lewis



Structure ID: S-2-3 ST-MH

P2 MH048LD12ECC

MH FLAT TOP w/ 24" ECC Hole F/G

- P3) 24" - CASTING HEIGHT - 7"
- P2) 48" - MH FLAT TOP w/ 24" ECC Hole F/G - 12"
- P1) 48" - MH BASE T/n - 24"
- 1) CASTING - HOE MC-420 F/C Storm
- 1) 48" - Conseal CS-102 1.00"
- 2) Hole - 18

	0 lb
	1561 lb
	2789 lb
	340 lb
	0 lb
	0 lb
Structure Total:	4690 lb

- Structure Notes:
1. PER LOUISVILLE MSD / ASTM C-478 SPECS
 2. CONCRETE: 4,000 PSI AT 28 DAYS
 3. REINFORCEMENT: #4 BAR @ 10" C.C. E.W. (GRADE 60) - 2" MIN. REBAR CLEARANCE (TYP)
 4. HOE MC-420 FRAME & COVER "STORM MSD" SUPPLIED BY ICAST
 5. LIFTERS: 3 EA. WRA016 CONAC WIRE ROPE ANCHORS FOR PLANT & FIELD HANDLING
 6. TOP SURFACE TO RECEIVE FLOATED FINISH

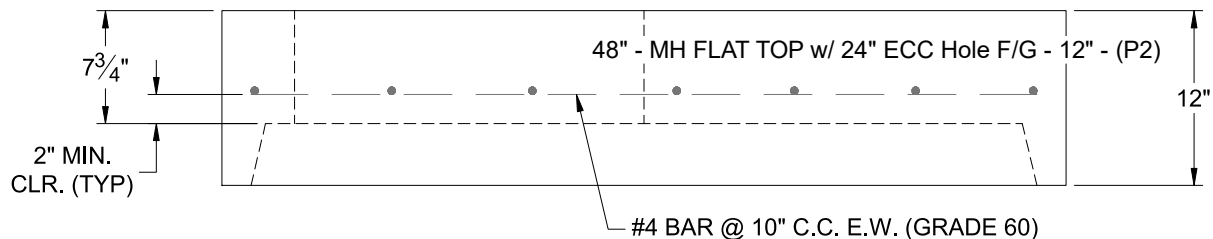
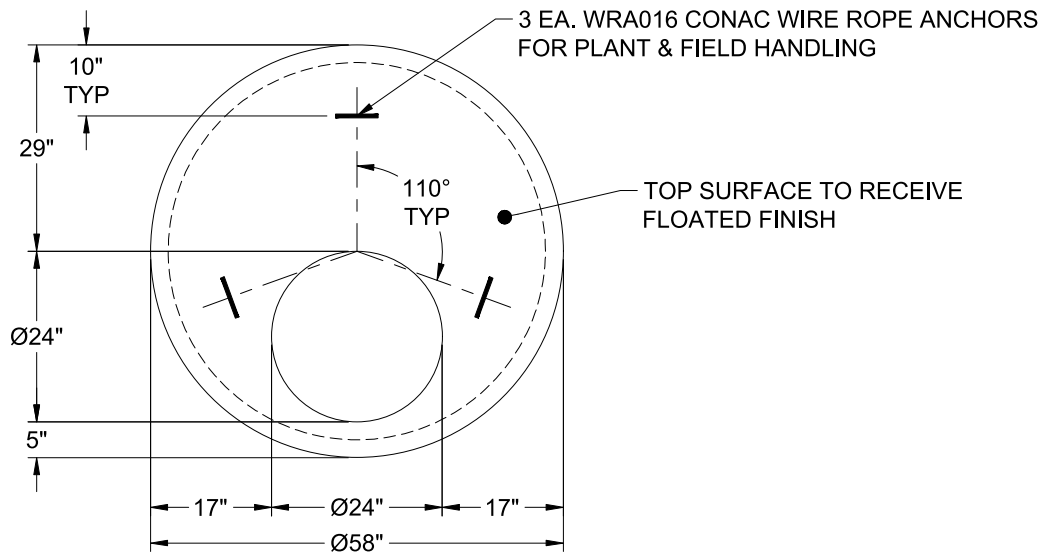

Coating (Int):
 Coating (Ext):

Seam Up: Flat
 Seam Dn: Groove

Wall Thickness: 5"

Height (Ext): 12"

Weight (Net): 1561 lb
 Volume (Net): 0.42cu.yd