

Job Name: 26-2087 839373 Georgetown Commons  
 Job Location: Georgetown, KY  
 Contractor: Contech Engineering Solutions

Plant: Beaver Dam  
 4/27/2026 2:30:09 PM

Tech: S. Felletter  
 PC: C. Goff



**Structure ID: 10-CS-10**

**P2 MH120RS84**

**MH RISER NO STEPS T/G**

- P5) 24" - CASTING HEIGHT - 4"
- P4) 120" - MH FLAT TOP SPEC. (2 - 24"Ø HOLES) F/G - 18"
- P3) 120" - MH RISER NO STEPS T/G - 36"
- P2) 120" - MH RISER NO STEPS T/G - 84"
- P1) 120" - MH MONOBASE 14F, Custom Ht T/n - 48"
- 1) CVSTENCILING
- 1) ASSEMBLY REQUIRED - BRACKETS ONLY
- 3) 120" - Conseal CS-102 1.00"
- 2) Hole - 32

0 lb  
 16223 lb  
 13675 lb  
 30395 lb  
 36838 lb  
 0 lb  
 0 lb  
 0 lb  
 0 lb  
 -----  
 Structure Total: 97131 lb

**Structure Notes:**  
 4" CASTING BY OTHERS  
  
 LIFTING ANCHORS TO BE INSTALLED ON THE OUTSIDE OF THE STRUCTURE  
  
 ICAST TO INSTALL BRACKETS ONLY  
  
 CONTECH'S LOGO AS WELL AS THE INLET AND OUTLET MUST BE STENCILED ONTO THE STRUCTURE

Rim: 867.8' Rim to Invert: 8.73' Slack: 6.836" Sump: 92.076" Step Position:

Position	Elev	Angle	Ext. (cw)	Pipe	Pipe OD	Connector	Hole	Horz Size	Up ( )	Offset
Invert 1	859.07'	270°	334.58"	24" HDPE	27.8"	Hole 32	32"	32.392"	34.076"	0"
Invert 2	859.07'	322°	411.075"	24" HDPE	27.8"	Hole 32	32"	33.134"	34.076"	12"
Invert 3										
Invert 4										
Invert 5										
Invert 6										
Invert 7										
Invert 8										

**RIGHT-SIDE UP VIEW (int. dimensions)**

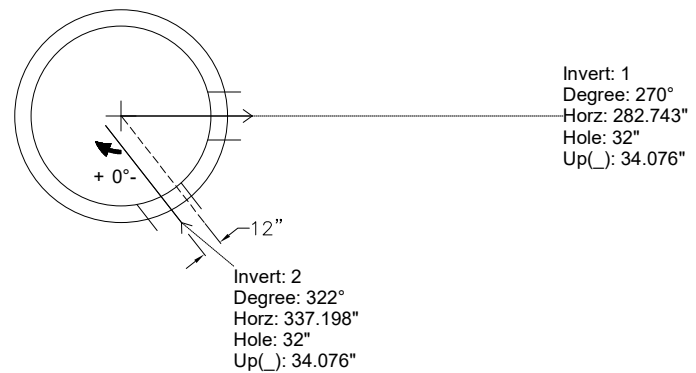
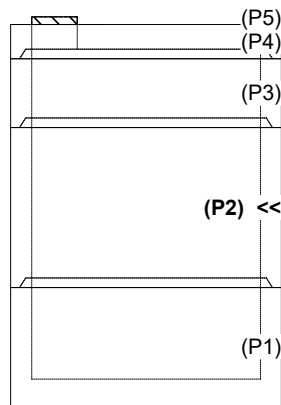

**INSIDE WALL DIMENSIONS**

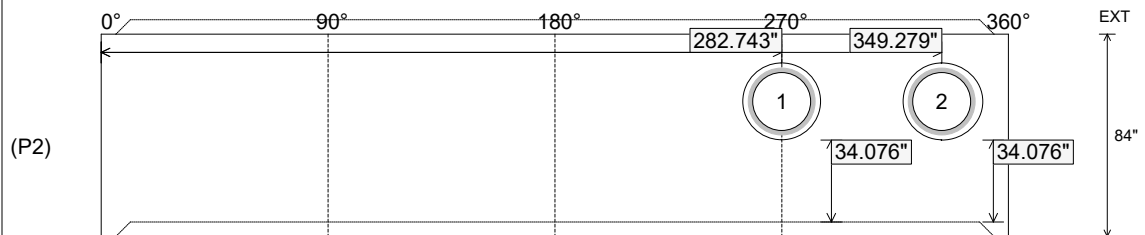

Coating (Int):  
 Coating (Ext):

Seam Up: Tongue  
 Seam Dn: Groove

Wall Thickness: 11"  
 Floor Height: 0"

Height (Int): 84"  
 Height (Ext): 84"

Weight (Net): 30395 lb  
 Volume (Net): 7.76cu.yd

**Structure ID: 20-CS-12**

**P2 MH144RS60**

**MH RISER T/G**

P6) 24" - CASTING HEIGHT - 4" P5) 144" - MH FLAT TOP w/ 24" ECC Hole F/G - 18" P4) 144" - MH RISER T/G - 36" P3) 144" - MH RISER T/G - 84" P2) 144" - MH RISER T/G - 60" P1) 144" - MH MONOBASE 14F, Custom Ht T/n - 24" 1) CVSTENCILING 1) ASSEMBLY REQUIRED - BRACKETS ONLY 4) 144" - Conseal CS-102 1.00" 2) Hole - 44	0 lb 24911 lb 19370 lb 41809 lb 32283 lb 39578 lb 0 lb 0 lb 0 lb 0 lb ----- Structure Total: 157950 lb	<b>Structure Notes:</b> 4" CASTING BY OTHERS  LIFTING ANCHORS TO BE INSTALLED ON THE OUTSIDE OF THE STRUCTURE  ICAST TO INSTALL BRACKETS ONLY  CONTECH'S LOGO AS WELL AS THE INLET AND OUTLET MUST BE STENCILED ONTO THE STRUCTURE
--	---	---

Rim: 866.5' Rim to Invert: 10.35' Slack: 6.236" Sump: 108.036" Step Position:

Position	Elev	Angle	Ext. (cw)	Pipe	Pipe OD	Connector	Hole	Horz Size	Up (L)	Offset
Invert 1										
Invert 2										
Invert 3										
Invert 4										
Invert 5										
Invert 6										
Invert 7										
Invert 8										

**RIGHT-SIDE UP VIEW (int. dimensions)**

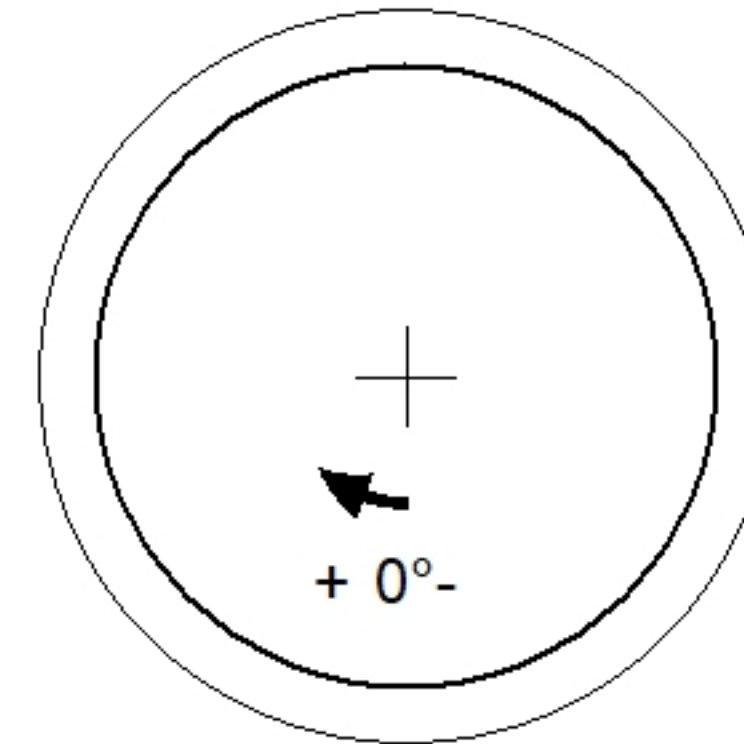
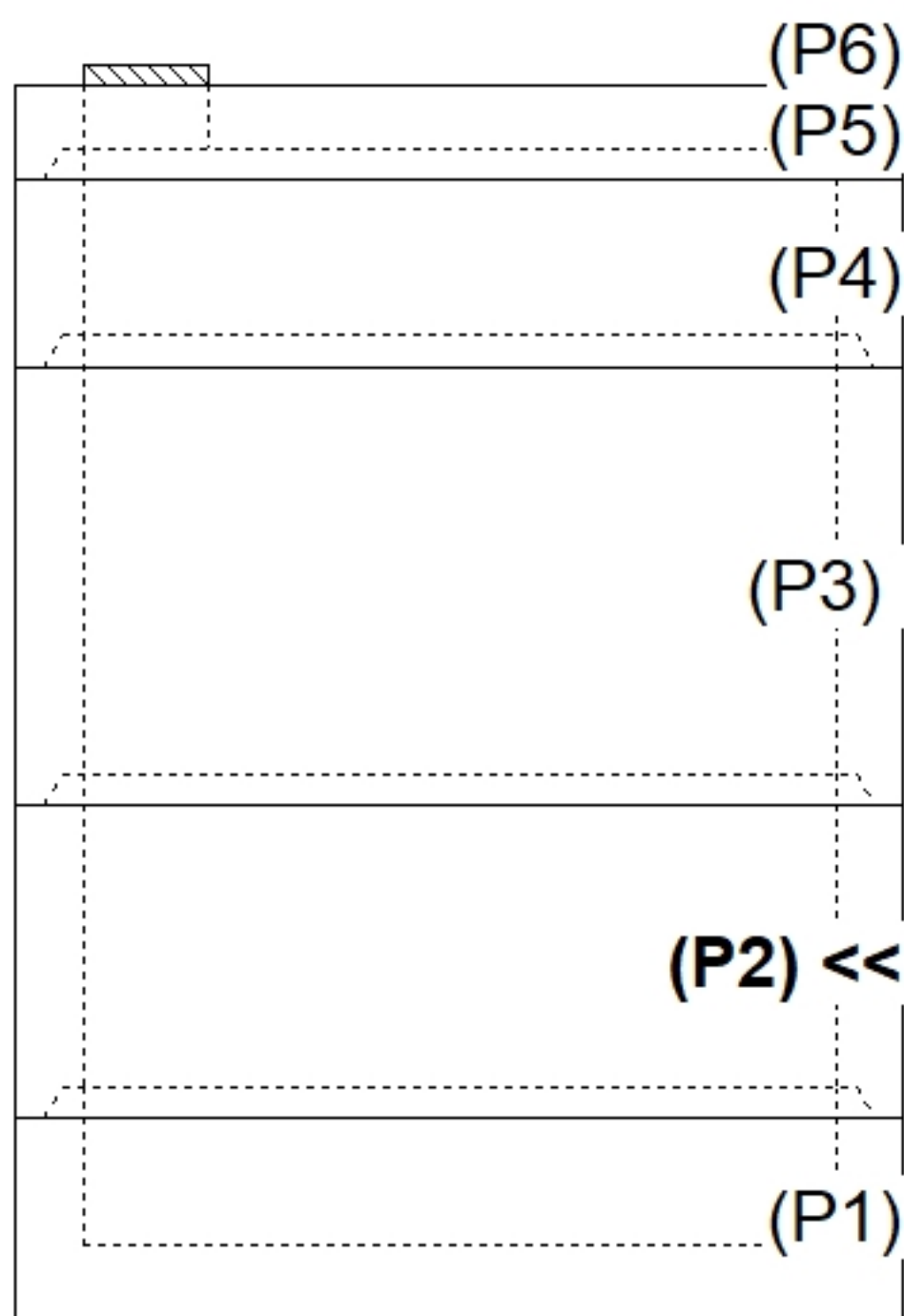

**INSIDE WALL DIMENSIONS**

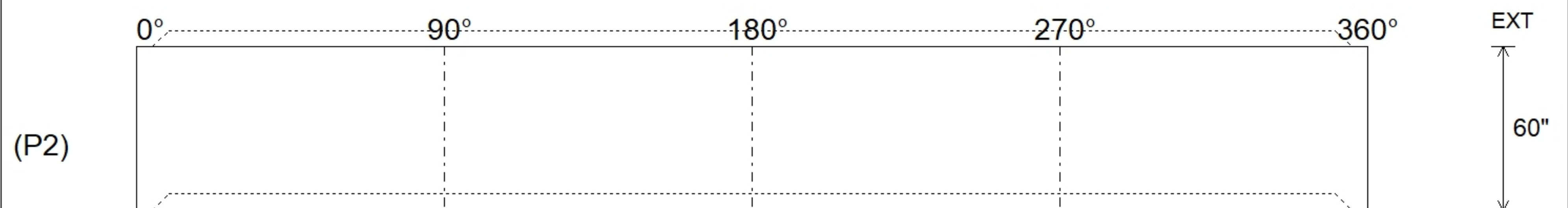

Coating (Int): Coating (Ext):	Seam Up: Tongue Seam Dn: Groove	Wall Thickness: 13" Floor Height: 0"	Height (Int): 60" Height (Ext): 60"	Weight (Net): 32283 lb Volume (Net): 8.25cu.yd
----------------------------------	------------------------------------	---	--	---

Job Name: 26-2124 833344 The Kingdom Center  
 Job Location: Louisville, KY  
 Contractor: Contech Engineering Solutions

Plant: Beaver Dam  
 4/30/2026 1:48:04 PM

Tech: S. Felletter  
 PC: C. Goff



**Structure ID: 10-CS-3**

**P3 MH036LD10-30ECC**

**MH FLAT LID w/30in ECC Hole F/G**

- P4) 30" - CASTING HEIGHT - 4"
- P3) 36" - MH FLAT LID w/30in ECC Hole F/G - 10"
- P2) 36" - MH RISER T/G - 48"
- P1) 36" - MH BASE T/h - 12"
- 1) CVSTENCILING
- 1) ASSEMBLY REQUIRED
- 2) 36" - Conseal CS-102 1.00"
- 2) Hole - 16

	0 lb
	683 lb
	1871 lb
	1272 lb
	0 lb
	0 lb
	0 lb
	0 lb
Structure Total:	3826 lb

Structure Notes:  
 4" CASTING BY OTHERS  
  
 LIFTING ANCHORS TO BE INSTALLED ON THE OUTSIDE OF THE STRUCTURE  
  
 ICAST TO INSTALL THE INTERNALS  
  
 CONTCH'S LOGO AS WELL AS THE INLET AND OUTLET MUST BE STENCILED ONTO THE STRUCTURE

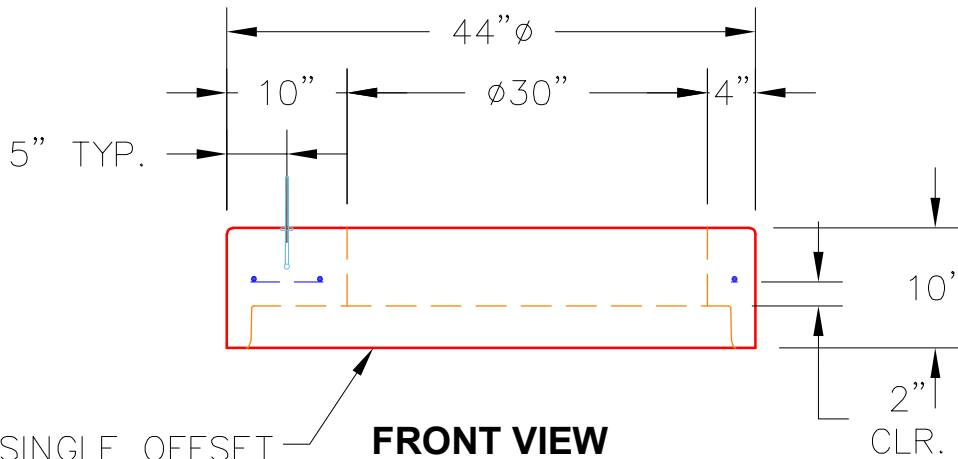
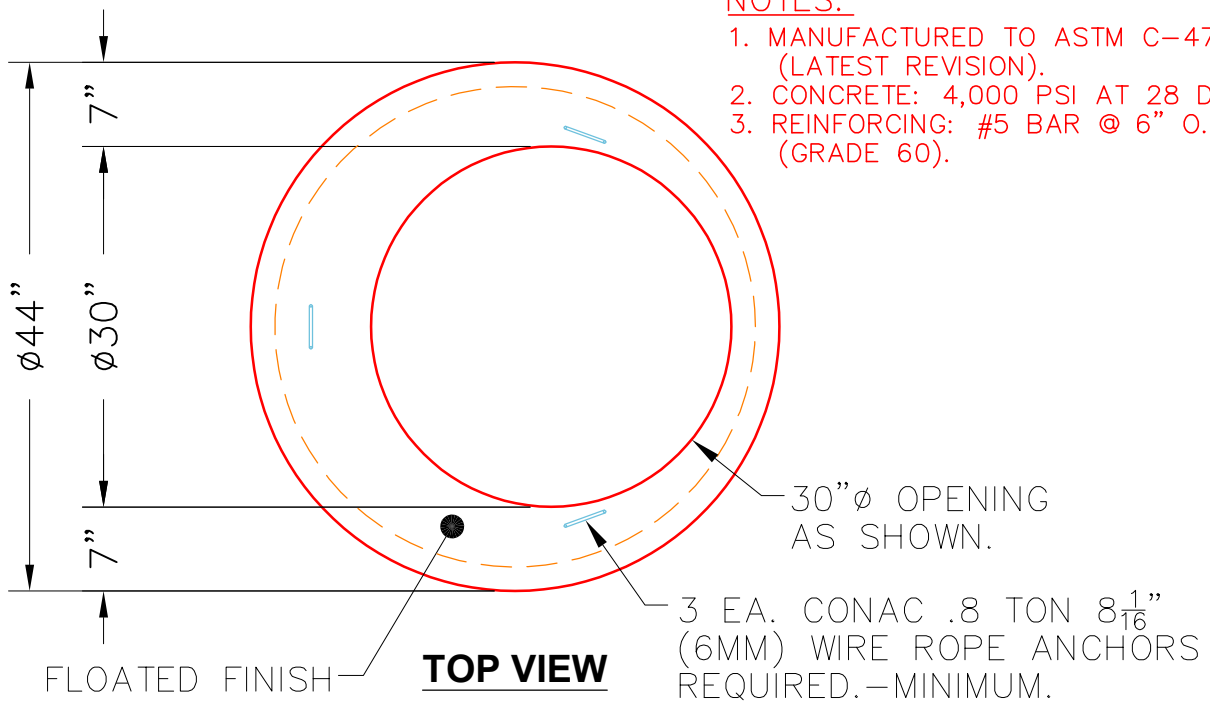

Coating (Int): Coating (Ext):	Seam Up: Flat Seam Dn: Groove	Wall Thickness: 4"	Height (Ext): 0.833'	Weight (Net): 683 lb Volume (Net): 0.17cu.yd
----------------------------------	----------------------------------	--------------------	----------------------	---

Job Name: 26-1228 - L&N Federal Credit Union  
 Job Location: Louisville, KY 40243  
 Contractor: H & W Landworks

Plant: 100

5/6/2026 12:05:51 PM

Tech: Jared - A

PC: T. Lewis



**Structure ID: S-2-3 ST-MH**

**P2 MH048LD12ECC**

**MH FLAT TOP w/ 24" ECC Hole F/G**

- P3) 24" - CASTING HEIGHT - 7"
- P2) 48" - MH FLAT TOP w/ 24" ECC Hole F/G - 12"
- P1) 48" - MH BASE T/n - 24"
- 1) CASTING - HOE MC-420 F/C Storm
- 1) 48" - Conseal CS-102 1.00"
- 2) Hole - 18

	0 lb
	1561 lb
	2789 lb
	340 lb
	0 lb
	0 lb
Structure Total:	4690 lb

- Structure Notes:
1. PER LOUISVILLE MSD / ASTM C-478 SPECS
  2. CONCRETE: 4,000 PSI AT 28 DAYS
  3. REINFORCEMENT: #4 BAR @ 10" C.C. E.W. (GRADE 60) - 2" MIN. REBAR CLEARANCE (TYP)
  4. HOE MC-420 FRAME & COVER "STORM MSD" SUPPLIED BY ICAST
  5. LIFTERS: 3 EA. WRA016 CONAC WIRE ROPE ANCHORS FOR PLANT & FIELD HANDLING
  6. TOP SURFACE TO RECEIVE FLOATED FINISH

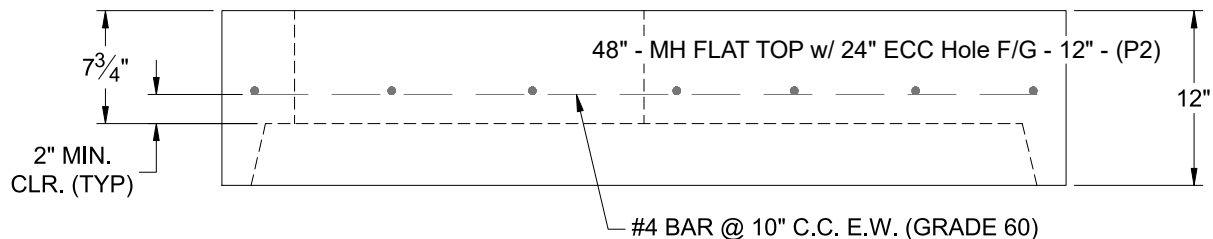
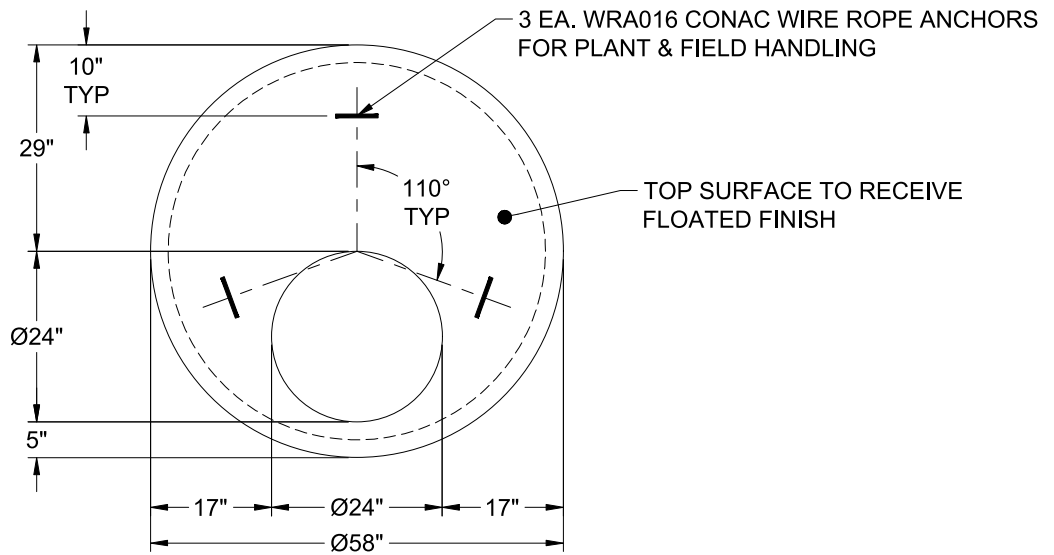

Coating (Int):  
 Coating (Ext):

Seam Up: Flat  
 Seam Dn: Groove

Wall Thickness: 5"

Height (Ext): 12"

Weight (Net): 1561 lb  
 Volume (Net): 0.42cu.yd

Job Name: 26-1228 - L&N Federal Credit Union  
 Job Location: Louisville, KY 40243  
 Contractor: H & W Landworks

Plant: 100

5/6/2026 12:05:51 PM

Tech: Jared - A

PC: T. Lewis



**Structure ID: S-1-2 SCI**

**P2 MH048LD07-2430 LOU-MSD**

**MH FLAT TOP w/24"x30" Hole LOU-MSD F/F**

- P3) 24" x 30" - CASTING HEIGHT - 6"
- P2) 48" - MH FLAT TOP w/24"x30" Hole LOU-MSD F/F - 7"
- P1) 48" - MH BASE Custom Ht F/n - 27"
- 1) CASTING - HOE 360 L Vane Set (F/G/H)
- 1) 48" - Conseal CS-102 1.00"
- 1) 24" x 30" - Conseal CS-102 1.00"
- 2) Hole - 18"

0 lb  
 1129 lb  
 2998 lb  
 362 lb  
 0 lb  
 0 lb  
 0 lb  
 -----  
 4489 lb

Structure Total:

Structure Notes:

1. PER LOUISVILLE MSD / ASTM C-913 SPECS
2. CONCRETE: 4,000 PSI AT 28 DAYS
3. REINFORCEMENT: #6 BAR @ 4" C.C. E.W. (GRADE 60) - 2" MIN. REBAR CLEARANCE (TYP)
4. HOE 360 FRAME, L-VANE GRATE, & CURB HOOD SUPPLIED BY ICAST
5. LIFTERS: 3 EA. WRA016 CONAC WIRE ROPE ANCHORS FOR PLANT & FIELD HANDLING
6. TOP SURFACE TO RECEIVE FLOATED FINISH

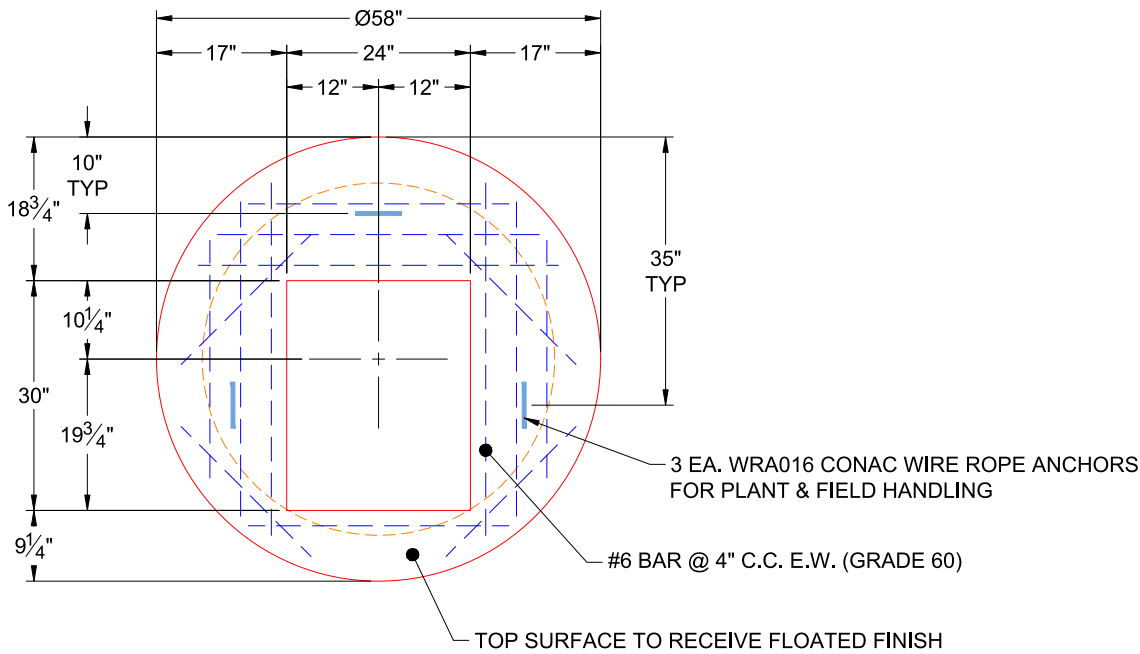

**PLAN VIEW  
(RIGHT SIDE UP)**

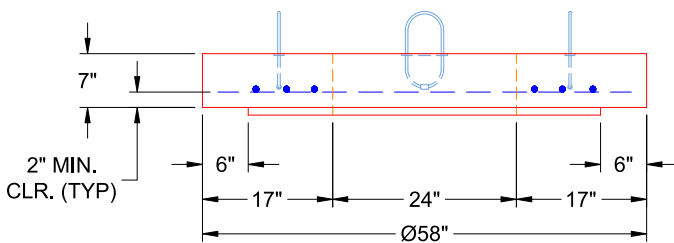

**FRONT VIEW  
(RIGHT SIDE UP)**

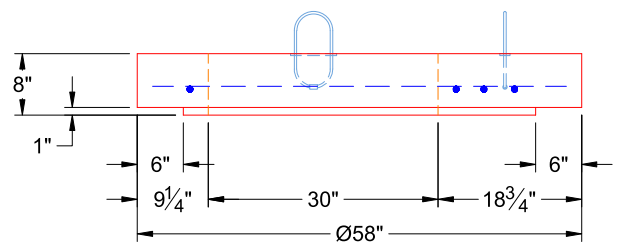

**SIDE VIEW  
(RIGHT SIDE UP)**

Coating (Int):  
 Coating (Ext):

Seam Up: Flat  
 Seam Dn: Flat

Wall Thickness: 5"

Height (Ext): 7"

Weight (Net): 1129 lb  
 Volume (Net): 0.29cu.yd

Job Name: 26-1210 Sacramento Gravity Sewer	Plant: Beaver Dam	Tech: S. Felletter	
Job Location: Sacramento, KY Contractor: Scott & Ritter, Inc.	4/24/2026 8:10:25 AM	PC: T. Lewis	

**Structure ID: CMH4-22 SS-MH**

**P2 MH048RS36**

**MH RISER T/G**

P4) 24" - CASTING HEIGHT - 7"	0 lb
P3) 48" - ECC CONE w/ 24" HOLE F/G - 24"	1550 lb
P2) 48" - MH RISER T/G - 36"	2515 lb
P1) 48" - MH BASE T/n - 42"	4121 lb
1) JOINT WRAP - 0.065"x6"x50' CONSEAL CS212	0 lb
1) JOINT WRAP PRIMER - CONSEAL CS-75 (1 gal.)	0 lb
1) 48" - MH INVERT CHANNEL - FULL HEIGHT	1440 lb
2) 48" - Conseal CS-102 1.00" (Double)	0 lb
3) PSX - 12-08 DD (DBL Bands)	24 lb
8) MH Step ML-10-TDS-NCR - 10"	0 lb
Structure Total:	9650 lb

**Structure Notes:**  
 1. PER ASTM C478 SPECIFICATIONS.  
 2. CONCRETE = 4,000 PSI AT 28 DAYS.  
 3. CASTING BY OTHERS.

REINFORCING PER ASTM A615 (GRADE 60).  
 - CONE (As .12)  
 - RISER/WALLS (As .12)  
 - FLOOR (As .31) #5 BARS AT 12" C.C.E.W.

Rim: 496' Rim to Invert: 8.99' Slack: 0.88" Sump: 2" Step Position: 0°

Position	Elev	Angle	Ext. (cw)	Pipe	Pipe OD	Connector	Hole	Horz Size	Up (L)	Offset
Invert 1										
Invert 2										
Invert 3										
Invert 4										
Invert 5										
Invert 6										
Invert 7										
Invert 8										

**RIGHT-SIDE UP VIEW (int. dimensions)**

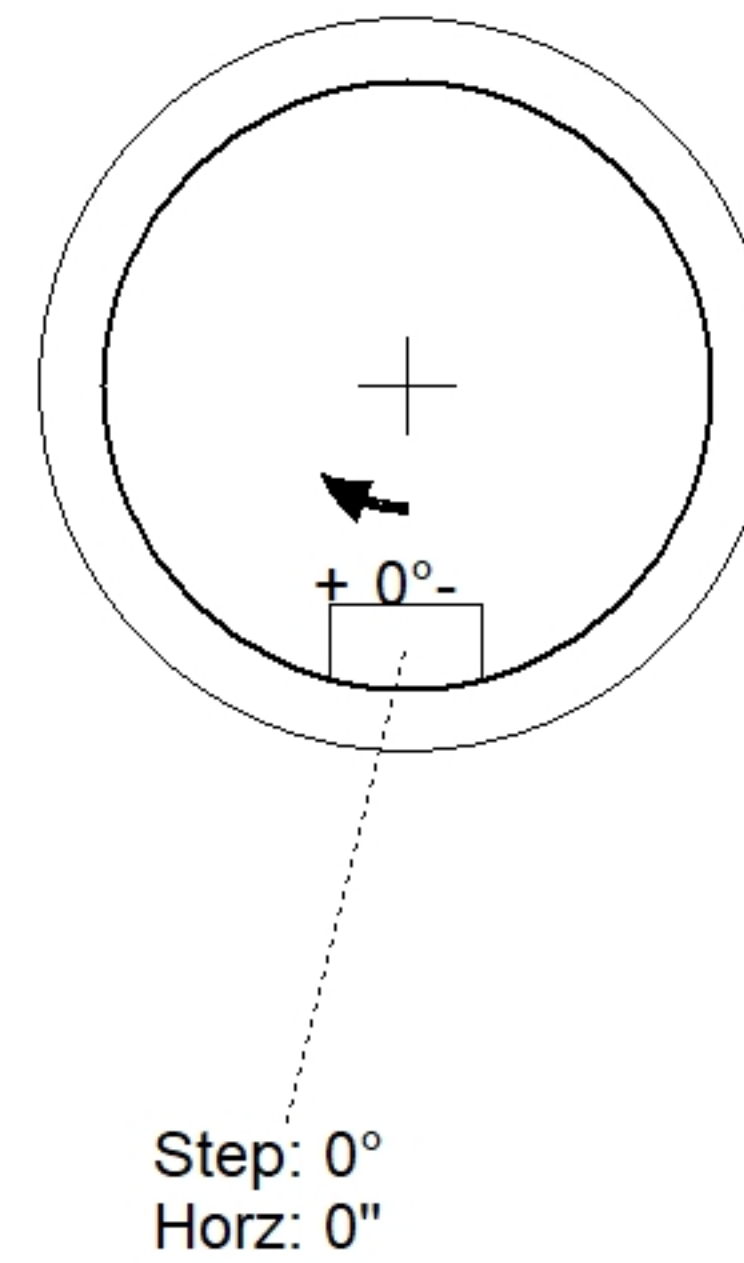
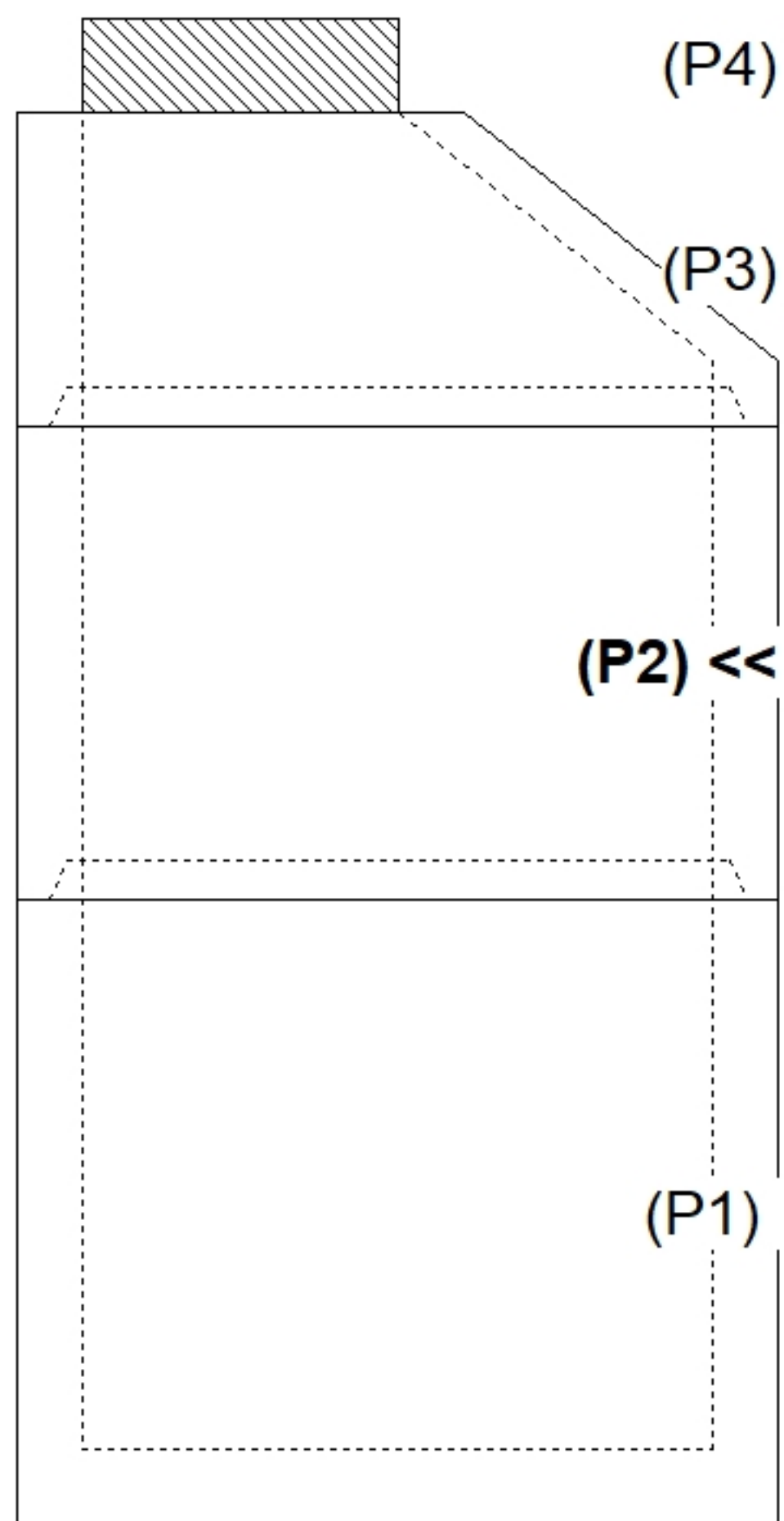

**INSIDE WALL DIMENSIONS**

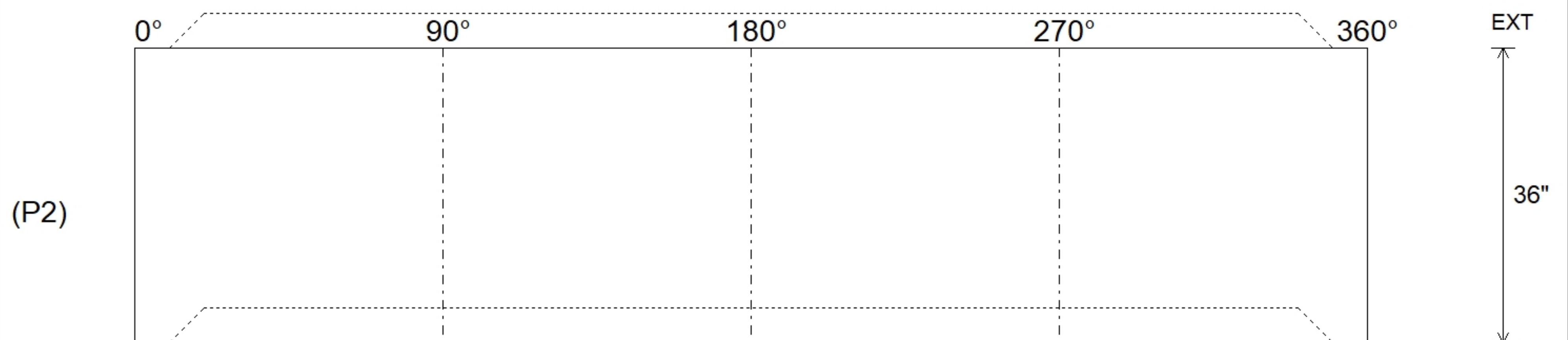

Coating (Int):	Seam Up: Tongue	Wall Thickness: 5"	Height (Int): 36"	Weight (Net): 2515 lb
Coating (Ext):	Seam Dn: Groove	Floor Height: 0"	Height (Ext): 36"	Volume (Net): 0.64cu.yd

Job Name: 26-1210 Sacramento Gravity Sewer Job Location: Sacramento, KY Contractor: Scott & Ritter, Inc.	Plant: Beaver Dam	Tech: S. Felletter	
	4/24/2026 8:09:30 AM	PC: T. Lewis	

**Structure ID: BMH5-16 SS-MH**

**P3 MH048CN30**

**ECC CONE w/ 24" HOLE F/G**

P5) 24" - CASTING HEIGHT - 7"	0 lb
P4) 24" - GRADE RING F/F - 3"	202 lb
P3) 48" - ECC CONE w/ 24" HOLE F/G - 30"	2050 lb
P2) 48" - MH RISER T/G - 48"	3353 lb
P1) 48" - MH BASE T/n - 30"	3330 lb
1) JOINT WRAP - 0.065"x6"x50' CONSEAL CS212	0 lb
1) JOINT WRAP PRIMER - CONSEAL CS-75 (1 gal.)	0 lb
1) 48" - MH INVERT CHANNEL - FULL HEIGHT	1440 lb
2) 48" - Conseal CS-102 1.00" (Double)	0 lb
2) PSX - 12-08 DD (DBL Bands)	16 lb
9) MH Step ML-10-TDS-NCR - 10"	0 lb
Structure Total:	10392 lb

Structure Notes:  
 1. PER ASTM C478 SPECIFICATIONS.  
 2. CONCRETE = 4,000 PSI AT 28 DAYS.  
 3. CASTING BY OTHERS.

REINFORCING PER ASTM A615 (GRADE 60).  
 - CONE (As .12)  
 - RISER/WALLS (As .12)  
 - FLOOR (As .31) #5 BARS AT 12" C.C.E.W.

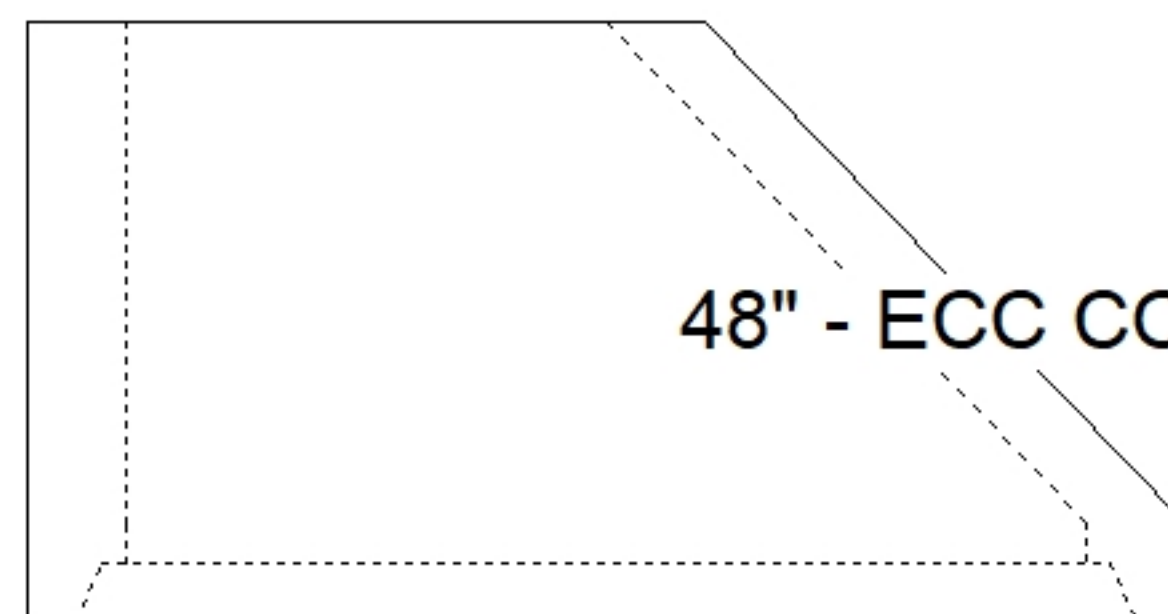
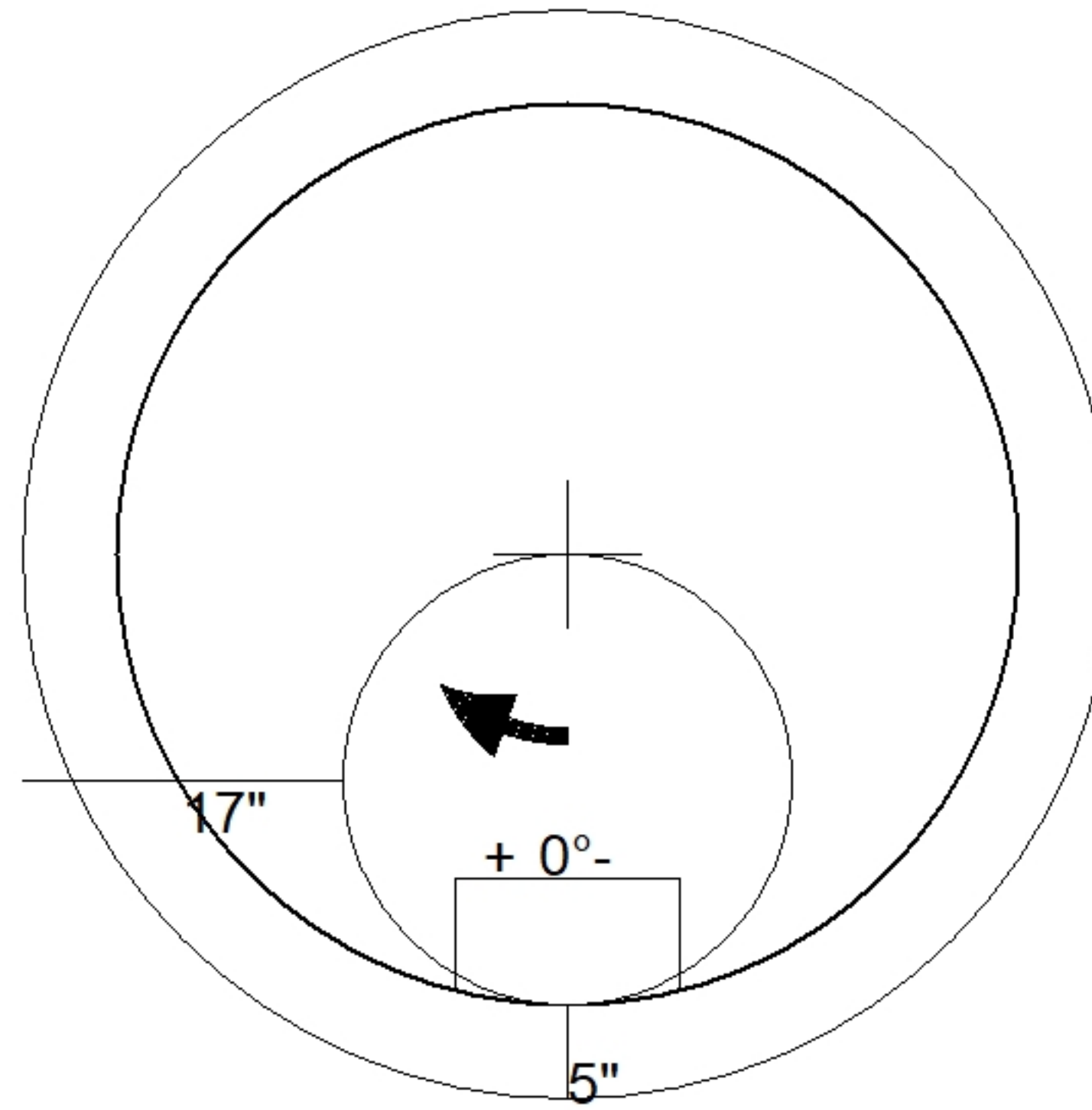

48" - ECC CONE w/ 24" HOLE F/G - 30" - (P3)

Coating (Int): Coating (Ext):	Seam Up: Flat Seam Dn: Groove	Wall Thickness: 5"	Height (Ext): 30"	Weight (Net): 2050 lb Volume (Net): 0.41cu.yd
----------------------------------	----------------------------------	--------------------	-------------------	--

Job Name: 26-1210 Sacramento Gravity Sewer	Plant: Beaver Dam	Tech: S. Felletter	
Job Location: Sacramento, KY Contractor: Scott & Ritter, Inc.	4/24/2026 8:09:29 AM	PC: T. Lewis	

**Structure ID: BMH3-14 SS-MH**

**P3 MH048CN36**

**ECC CONE w/ 24" HOLE F/G**

P5) 24" - CASTING HEIGHT - 7"	0 lb
P4) 24" - GRADE RING F/F - 3"	202 lb
P3) 48" - ECC CONE w/ 24" HOLE F/G - 36"	3000 lb
P2) 48" - MH RISER T/G - 48"	3353 lb
P1) 48" - MH BASE T/n - 18"	2492 lb
1) JOINT WRAP - 0.065"x6"x50' CONSEAL CS212	0 lb
1) JOINT WRAP PRIMER - CONSEAL CS-75 (1 gal.)	0 lb
1) 48" - MH INVERT CHANNEL - FULL HEIGHT	1440 lb
2) 48" - Conseal CS-102 1.00" (Double)	0 lb
2) PSX - 12-08 DD (DBL Bands)	16 lb
8) MH Step ML-10-TDS-NCR - 10"	0 lb
Structure Total:	10504 lb

Structure Notes:  
 1. PER ASTM C478 SPECIFICATIONS.  
 2. CONCRETE = 4,000 PSI AT 28 DAYS.  
 3. CASTING BY OTHERS.

REINFORCING PER ASTM A615 (GRADE 60).  
 - CONE (As .12)  
 - RISER/WALLS (As .12)  
 - FLOOR (As .31) #5 BARS AT 12" C.C.E.W.

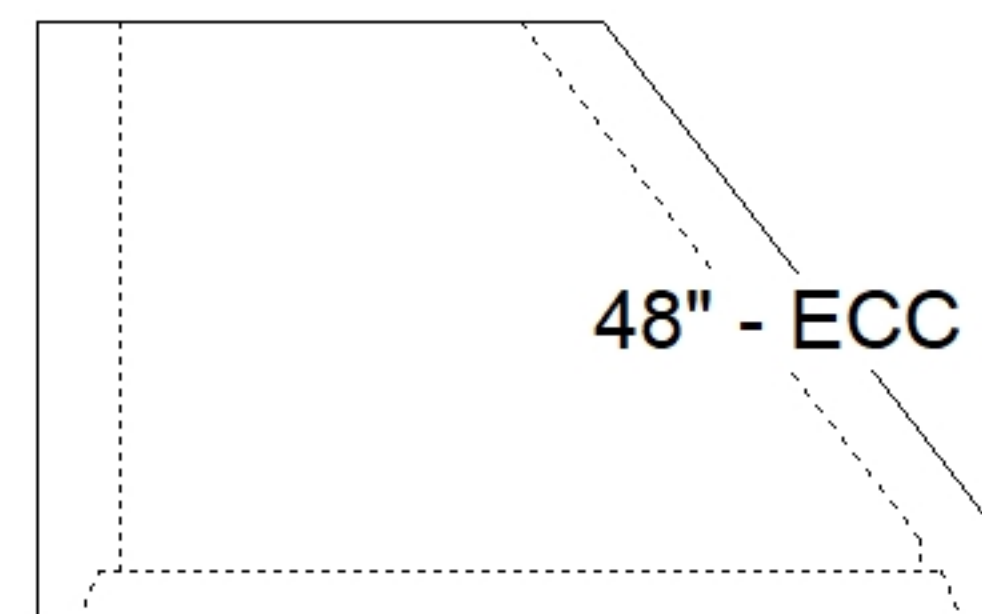
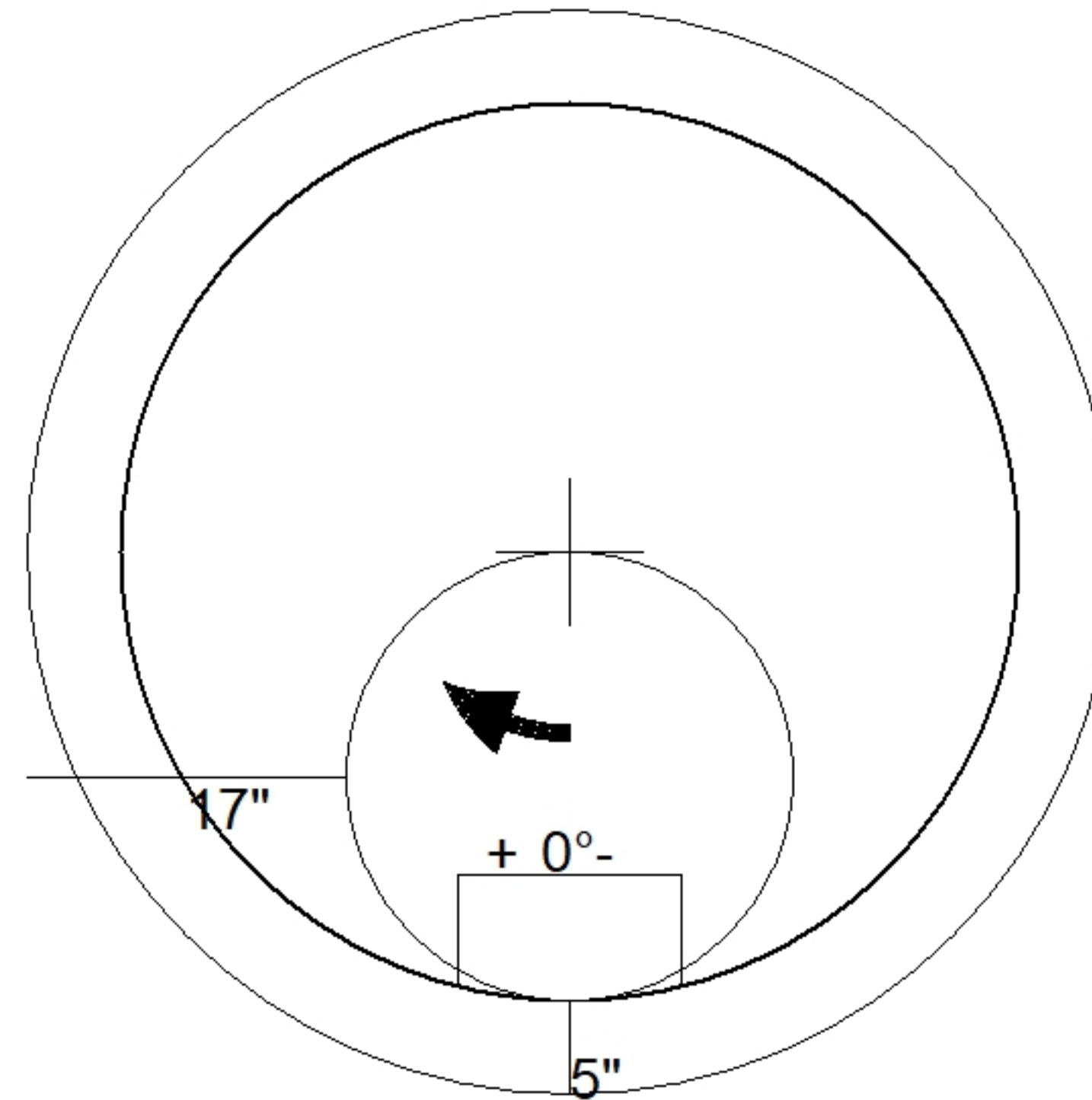

48" - ECC CONE w/ 24" HOLE F/G - 36" - (P3)

Coating (Int):	Seam Up: Flat	Wall Thickness: 5"	Height (Ext): 36"	Weight (Net): 3000 lb
Coating (Ext):	Seam Dn: Groove			Volume (Net): 0.5cu.yd

Job Name: 25-3452 - Churchill Downs Skye Terrace Improvements  
 Job Location: Louisville, KY 40208  
 Contractor: Louisville Paving and Construction

Plant: 100  
 4/30/2026 1:22:57 PM

Tech: Jared - F  
 PC: J. Jarvis



**Structure ID: S107**

**P2 MH048LD12S**

**MH FLAT TOP w/32"x32" Hole F/G**

- P3) 32" x 32" - CASTING HEIGHT - 3"
- P2) 48" - MH FLAT TOP w/32"x32" Hole F/G - 12"
- P1) 48" - MH BASE Custom Ht T/n - 70"
- 1) CASTING - HOE 595 F/G
- 1) 48" - Conseal CS-102 1.00"
- 1) 32" x 32" - Conseal CS-102 1.00"
- 1) Hole - 20
- 1) Hole - 22
- 1) Hole - 16

0 lb  
 1629 lb  
 5835 lb  
 376 lb  
 0 lb  
 0 lb  
 0 lb  
 0 lb  
 0 lb  
 0 lb  
 Structure Total: 7840 lb

**Structure Notes:**  
 1. PER ASTM C478 SPECIFICATIONS.  
 2. CONCRETE = 4,000 PSI AT 28 DAYS.  
 3. NO STEPS AND NO INVERT CHANNEL.  
 4. CASTING BY ICAST (HOE 595 F/G)

REINFORCING PER ASTM A615 (GRADE 60).  
 - TOP SLAB (As .62) #5 BARS AT 6" C.C.E.W..  
 - RISER/WALLS (As .12)  
 - FLOOR (As .31) #5 BARS AT 12" C.C.E.W.

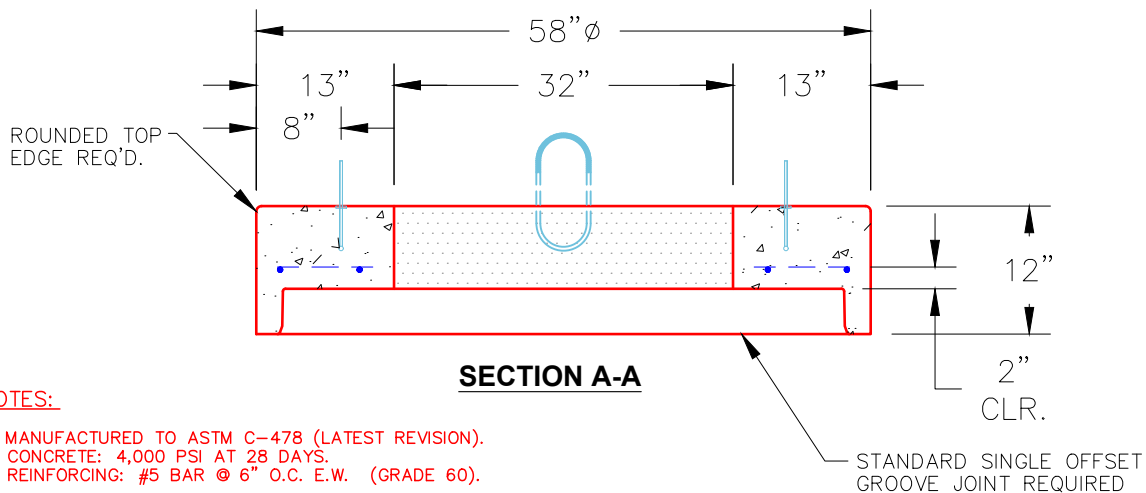
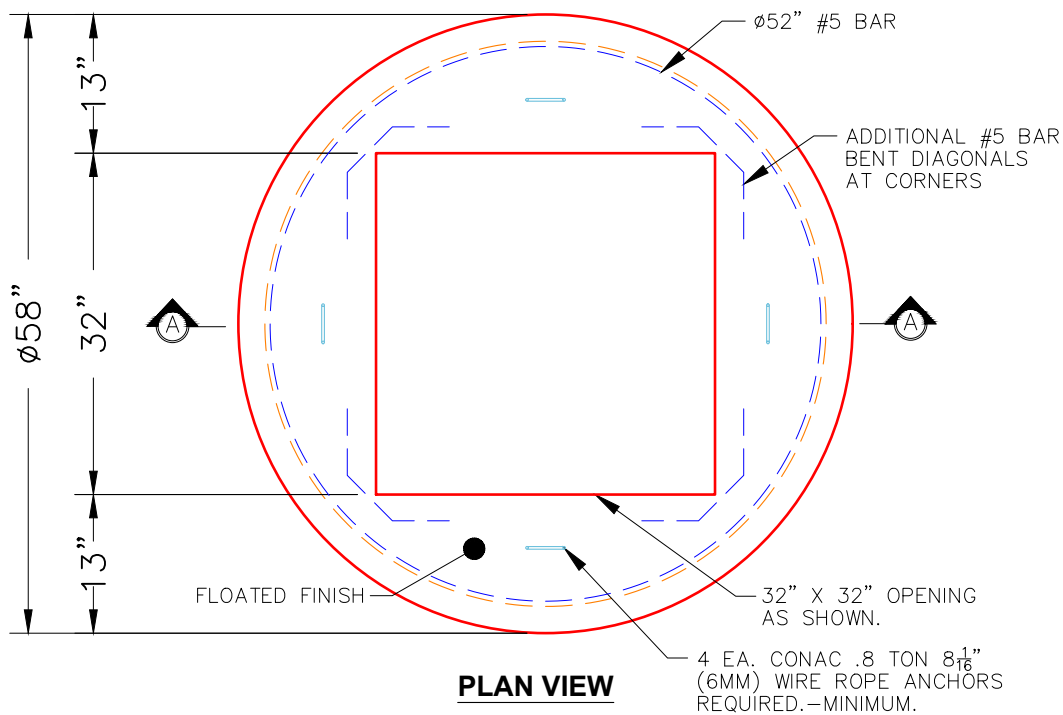

- NOTES:**
- 1. MANUFACTURED TO ASTM C-478 (LATEST REVISION).
  - 2. CONCRETE: 4,000 PSI AT 28 DAYS.
  - 3. REINFORCING: #5 BAR @ 6" O.C. E.W. (GRADE 60).

Coating (Int): Coating (Ext):	Seam Up: Flat Seam Dn: Groove	Wall Thickness: 5"	Height (Ext): 12"	Weight (Net): 1629 lb Volume (Net): 0.42cu.yd
----------------------------------	----------------------------------	--------------------	-------------------	--

Job Name: 26-1577 - Elkhorn Elementary Redesign  
 Job Location: Frankfort, KY 40601  
 Contractor: Louisville Paving and Construction

Plant: 100

5/5/2026 1:40:52 PM

Tech: Jared - A

PC: J. Jarvis



**Structure ID: MH3-5 SS-MH**

**P1 MH048BA36CDARED**

**MH BASE w/ConBlock-CDA Red T/n**

P4) 24" - CASTING HEIGHT - 7"	0 lb
P3) 24" - GRADE RING w/ConBlock-CDA Red F/F - 4"	270 lb
P2) 48" - ECC CONE w/ 24" HOLE, w/ConBlock-CDA Red F/G - 24"	1738 lb
P1) 48" - MH BASE w/ConBlock-CDA Red T/n - 36"	3749 lb
1) 48" - MH INVERT CHANNEL - FULL HEIGHT	1440 lb
1) JOINT WRAP - 12" WD x 048" MAC WRAP	0 lb
1) ADMIXTURE CONBLOCK CDA RED	0 lb
1) CASTING - HOE MC-350 F/C FSD	305 lb
1) 48" - Conseal CS-102 1.00" (Double)	0 lb
2) PSX - 12-08 NYLO	16 lb
<b>Structure Total:</b>	<b>7519 lb</b>

**Structure Notes:**

- PER ASTM C-478 SPECIFICATIONS
- CONCRETE: 4,000 PSI AT 28 DAYS
- REINFORCEMENT: PER ASTM A615
- INVERT CHANNEL REQUIRED
- CONBLOCK CDA RED ADMIXTURE REQUIRED
- NO STEPS
- HOE MC-350 FRAME & COVER "SANITARY FSD" SUPPLIED BY ICAST

Rim: 755.02' Rim to Invert: 5.87' Slack: 1.44" Sump: 2" Step Position:

Position	Elev	Angle	Ext. (cw)	Pipe	Pipe OD	Connector	Hole	Horz Size	Up ( )	Offset
Invert 1	749.15'	0°	0"	8" PVC SDR35	8.5"	PSX 12-08 NYLO	12"	12.129"	0"	0"
Invert 2	750.64'	268°	135.625"	8" PVC SDR35	8.5"	PSX 12-08 NYLO	12"	12.129"	17.875"	0"
Invert 3										
Invert 4										
Invert 5										
Invert 6										
Invert 7										
Invert 8										

RIGHT-SIDE UP VIEW (int. dimensions)

UPSIDE-DOWN VIEW (int. dimensions)

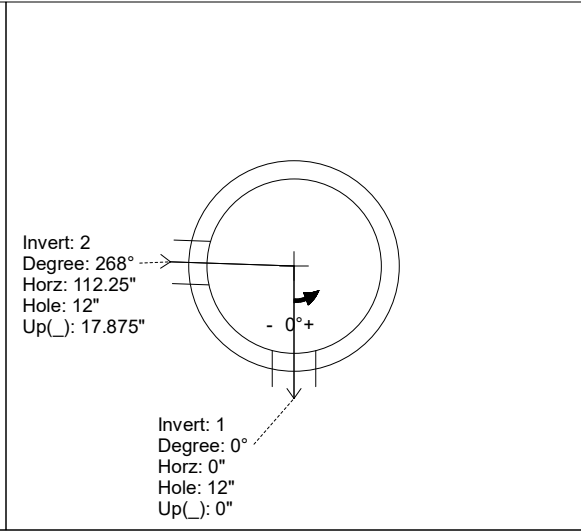
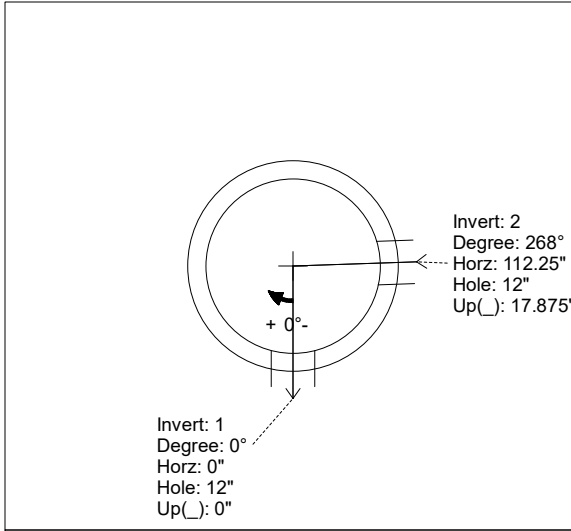
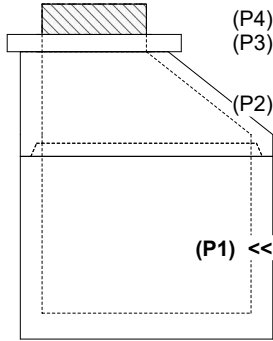

INSIDE WALL DIMENSIONS

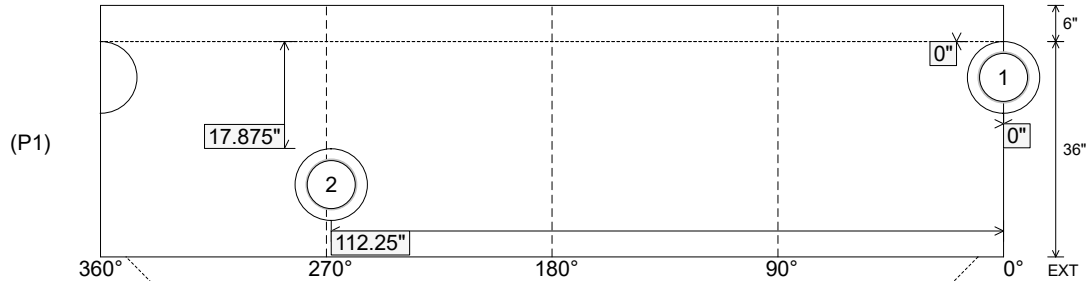

Coating (Int):  
Coating (Ext):

Seam Up: Tongue  
Seam Dn: n/a

Wall Thickness: 5"  
Floor Height: 6"

Height (Int): 36"  
Height (Ext): 42"

Weight (Net): 3749 lb  
Volume (Net): 0.96cu.yd

Job Name: 26-1577 - Elkhorn Elementary Redesign  
 Job Location: Frankfort, KY 40601  
 Contractor: Louisville Paving and Construction

Plant: 100

5/5/2026 1:40:52 PM

Tech: Jared - A

PC: J. Jarvis



**Structure ID: MH3-5 SS-MH**

**P1 MH048BA36CDARED**

**MH BASE w/ConBlock-CDA Red T/n**

- P4) 24" - CASTING HEIGHT - 7"
- P3) 24" - GRADE RING w/ConBlock-CDA Red F/F - 4"
- P2) 48" - ECC CONE w/ 24" HOLE, w/ConBlock-CDA Red F/G - 24"
- P1) 48" - MH BASE w/ConBlock-CDA Red T/n - 36"
- 1) 48" - MH INVERT CHANNEL - FULL HEIGHT
- 1) JOINT WRAP - 12" WD x 048" MAC WRAP
- 1) ADMIXTURE CONBLOCK CDA RED
- 1) CASTING - HOE MC-350 F/C FSD
- 1) 48" - Conseal CS-102 1.00" (Double)
- 2) PSX - 12-08 NYLO

0 lb  
 270 lb  
 1738 lb  
 3749 lb  
 1440 lb  
 0 lb  
 0 lb  
 305 lb  
 0 lb  
 16 lb  
 -----  
 Structure Total: 7519 lb

- Structure Notes:
1. PER ASTM C-478 SPECIFICATIONS
  2. CONCRETE: 4,000 PSI AT 28 DAYS
  3. REINFORCEMENT: PER ASTM A615
  4. INVERT CHANNEL REQUIRED
  5. CONBLOCK CDA RED ADMIXTURE REQUIRED
  6. NO STEPS
  7. HOE MC-350 FRAME & COVER "SANITARY FSD" SUPPLIED BY ICAST

Rim: 755.02' Rim to Invert: 5.87' Slack: 1.44" Sump: 2" Step Position:

Position	Elev	Angle	Ext. (cw)	Pipe	Pipe OD	Connector	Hole	Horz Size	Up ( )	Offset
Invert 1	749.15'	0°	0"	8" PVC SDR35	8.5"	PSX 12-08 NYLO	12"	12.129"	0"	0"
Invert 2	750.64'	268°	135.625"	8" PVC SDR35	8.5"	PSX 12-08 NYLO	12"	12.129"	17.875"	0"
Invert 3										
Invert 4										
Invert 5										
Invert 6										
Invert 7										
Invert 8										

RIGHT-SIDE UP VIEW (int. dimensions)

UPSIDE-DOWN VIEW (int. dimensions)

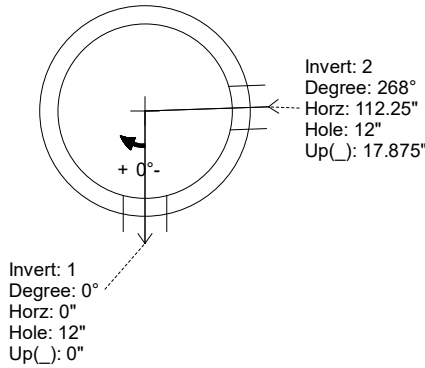
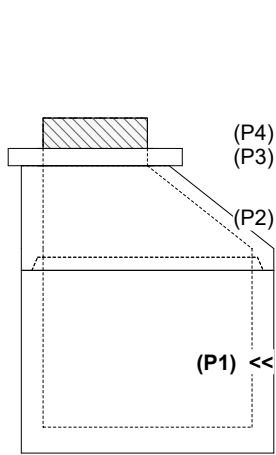

**INVERT CHANNEL DRAWING**

INSIDE WALL DIMENSIONS

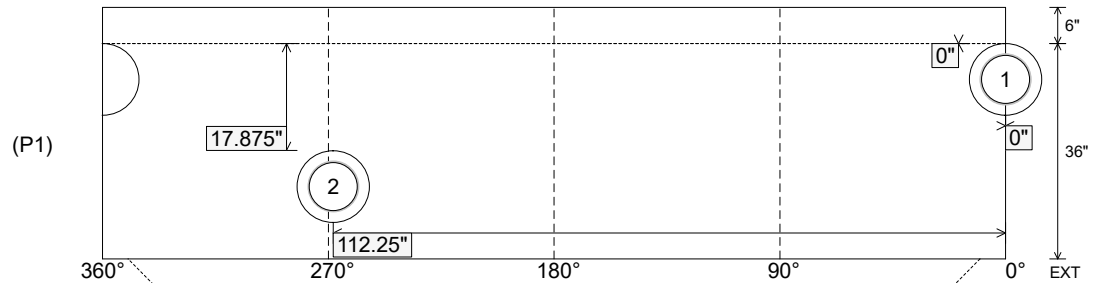

Coating (Int):  
 Coating (Ext):

Seam Up: Tongue  
 Seam Dn: n/a

Wall Thickness: 5"  
 Floor Height: 6"

Height (Int): 36"  
 Height (Ext): 42"

Weight (Net): 3749 lb  
 Volume (Net): 0.96cu.yd

Job Name: 26-1577 - Elkhorn Elementary Redesign  
 Job Location: Frankfort, KY 40601  
 Contractor: Louisville Paving and Construction

Plant: 100

5/5/2026 1:40:51 PM

Tech: Jared - A

PC: J. Jarvis



**Structure ID: MH503-3 ST-MH**

**P1 MH048BAVF**

**MH BASE Custom Ht F/n**

- P3) 24" - CASTING HEIGHT - 7"
- P2) 48" - MH FLAT TOP SPEC. HT. (6") w/24" ECC Hole F/F - 6"
- P1) 48" - MH BASE Custom Ht F/n - 26"
- 1) CASTING - HOE MC-350 F/C Storm
- 1) 48" - Conseal CS-102 1.00"
- 1) DOGHOUSE INVRTD - 30"x26"
- 1) DOGHOUSE INVRTD - 24"x26"
- 1) DOGHOUSE INVRTD - 20"x20"

0 lb  
 771 lb  
 2444 lb  
 305 lb  
 0 lb  
 0 lb  
 0 lb  
 0 lb  
 0 lb  
 Structure Total: 3520 lb

- Structure Notes:
1. PER ASTM C-478 SPECIFICATIONS
  2. CONCRETE: 4,000 PSI AT 28 DAYS
  3. REINFORCEMENT: PER ASTM A615
  4. NO STORM INVERT
  5. NO STEPS
  6. HOE MC-350 FRAME & COVER "STORM" SUPPLIED BY ICAST
  7. CUSTOMER WILL BE RESPONSIBLE FOR NOTCHING TOP OF 24" HDPE TO FIT BELOW FLAT LID

Rim: 757.19' Rim to Invert: 3.16' Slack: 0.82" Sump: 1.9" Step Position:

Position	Elev	Angle	Ext. (cw)	Pipe	Pipe OD	Connector	Hole	Horz Size	Up ( )	Offset
Invert 1	754.03'	0°	0"	24" HDPE	27.8"	DOGHOUSE INVRTD 30"x26"	30" x 26"	32.406"	0"	0"
Invert 2	754.03'	132°	66.75"	18" HDPE	21.2"	DOGHOUSE INVRTD 24"x26"	24" x 26"	25.133"	0.25"	0"
Invert 3	754.5'	243°	123"	15" HDPE	17.6"	DOGHOUSE INVRTD 20"x20"	20" x 20"	20.629"	6.25"	0"
Invert 4										
Invert 5										
Invert 6										
Invert 7										
Invert 8										

RIGHT-SIDE UP VIEW (int. dimensions)

UPSIDE-DOWN VIEW (int. dimensions)

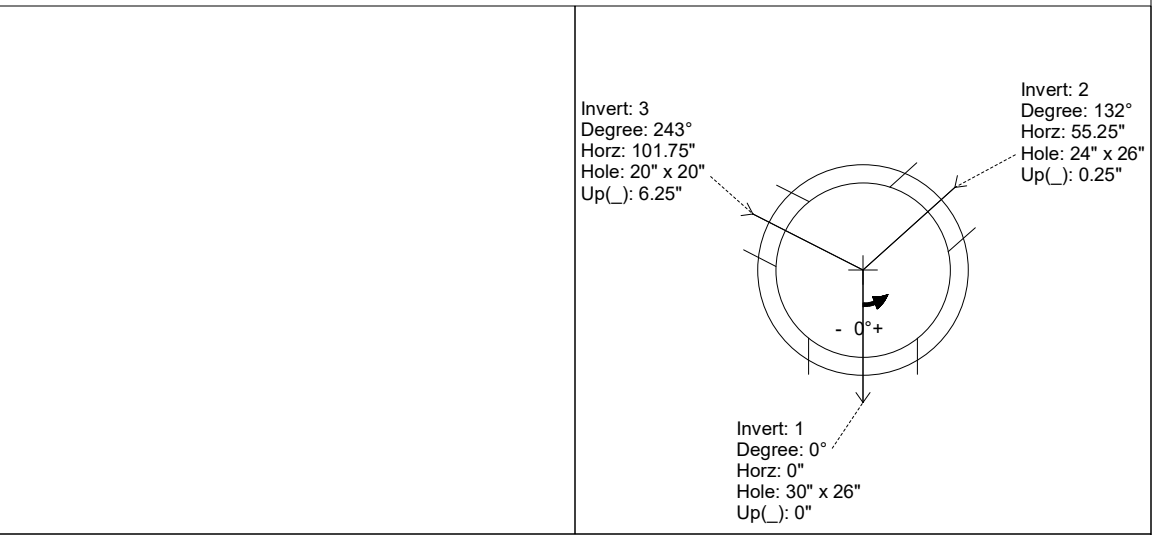
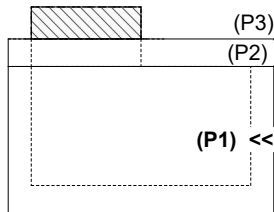

INSIDE WALL DIMENSIONS

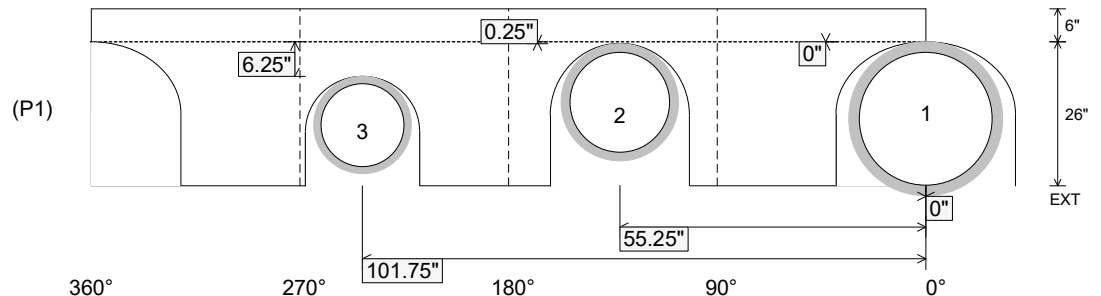

Coating (Int):  
 Coating (Ext):

Seam Up: Flat  
 Seam Dn: n/a

Wall Thickness: 5"  
 Floor Height: 6"

Height (Int): 26"  
 Height (Ext): 32"

Weight (Net): 2444 lb  
 Volume (Net): 0.62cu.yd

Job Name: 25-1431 - Georgetown Commons  
 Job Location: Georgetown, KY  
 Contractor: Winwater Hartford KY Co.

Plant: Beaver Dam  
 4/24/2026 2:18:07 PM

Tech: J. Coppage  
 PC: A. Chambers



**Structure ID: YD 72**

**P1 MH048BA48**

**MH BASE**

- P4) 24" x 24" - CASTING HEIGHT - 4"
- P3) 24" x 24" - GRADE RING - 4"
- P2) 48" - MH FLAT TOP w/24"x24" Hole - 12"
- P1) 48" - MH BASE - 48"
- 1) CASTING - HOE 280T F/G
- 1) 48" - Conseal CS-102 1.00"
- 2) 24" x 24" - Conseal CS-102 1.00"
- 1) Hole - 12
- 4) MH Step ML-10-TDS-NCR - 10"

- Structure Notes:**
1. JR HOE HOE-280T PROVIDED BY ICAST.
  2. PER ASTM C478 SPECIFICATIONS.
  3. CONCRETE = 4,000 PSI AT 28 DAYS.
  4. REINFORCING PER ASTM A615 (GRADE 60).  
 - TOP SLAB (As .62) #5 BARS AT 6" C.C.E.W..  
 - RISER/WALLS (As .12)  
 - FLOOR (As .31) #5 BARS AT 12" C.C.E.W.

Structure Total: 6661 lb

Rim: 867.75' Rim to Invert: 5.75' Slack: 1.55' Sump: 0.55' Step Position: 180°

Position	Elev	Angle	Ext. (cw)	Pipe	Pipe OD	Connector	Hole	Horz Size	Up ( )	Offset
Invert 1	862'	0°	0"	8" HDPE	9.1"	Hole 12	12"	12.129"	0"	0"
Invert 2										
Invert 3										
Invert 4										
Invert 5										
Invert 6										
Invert 7										
Invert 8										

RIGHT-SIDE UP VIEW (int. dimensions)

UPSIDE-DOWN VIEW (int. dimensions)

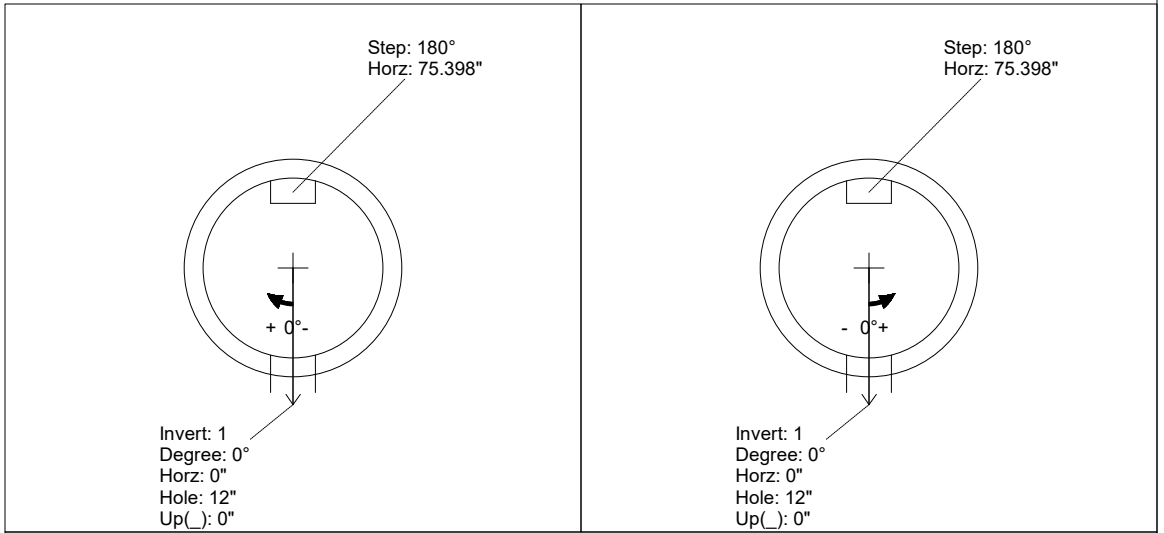
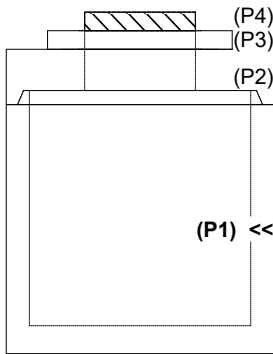

INSIDE WALL DIMENSIONS

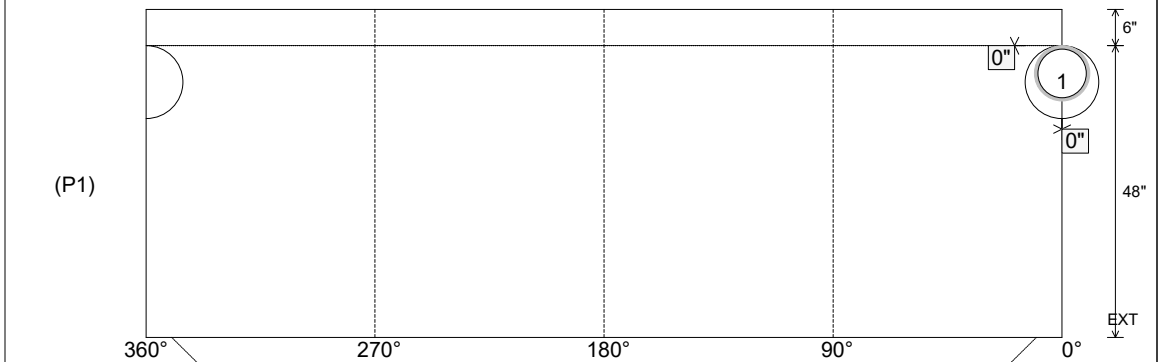

Coating (Int):  
 Coating (Ext):

Seam Up: Tongue  
 Seam Dn: n/a

Wall Thickness: 5"  
 Floor Height: 6"

Height (Int): 48"  
 Height (Ext): 54"

Weight (Net): 4636 lb  
 Volume (Net): 1.18cu.yd

Job Name: 26-1961 - Dollar Tree  
 Job Location: Hanson, KY  
 Contractor: Steve Pleasant Excavating

Plant: 100  
 4/30/2026 12:57:27 PM

Tech: Jared - F  
 PC: E. Bradley



**Structure ID: 1 SS-MHD**

**P1 MH048BAVF-D**

**MH BASE w/DROP Custom Ht T/n**

- P3) 24" - CASTING HEIGHT - 7"
- P2) 48" - MH FLAT TOP w/ 24" ECC Hole F/G - 12"
- P1) 48" - MH BASE w/DROP Custom Ht T/n - 65"
- 1) 48" - MH INVERT CHANNEL - FULL HEIGHT
- 1) JOINT WRAP - 12" WD x 048" MAC WRAP
- 1) CASTING - HOE MC-375 F/C Sanitary
- 1) 48" - Conseal CS-102 1.00" (Double)
- 1) A-Lok - 0285
- 1) Drop Tee - 4" PVC
- 1) Drop Elbow - 4" PVC
- 5) MH Step ML-10-TDS-NCR - 10"

0 lb  
 1561 lb  
 8888 lb  
 1440 lb  
 0 lb  
 271 lb  
 0 lb  
 1 lb  
 0 lb  
 0 lb  
 0 lb  
 0 lb  
 -----  
 Structure Total: 12161 lb

Structure Notes:

1. PER ASTM C478 SPECIFICATIONS.
2. CONCRETE = 4,000 PSI AT 28 DAYS.
3. CASTING BY ICAST (HOE MC-375 F/C SANITARY),
4. EXTERIOR DROP ASSEMBLY PROVIDED BY ICAST.

REINFORCING PER ASTM A615 (GRADE 60).  
 - TOP SLAB = H20 LOADING  
 - RISER/WALLS (As .12)  
 - FLOOR (As .31) #5 BARS AT 12" C.C.E.W.

Rim: 425.9' Rim to Invert: 6.84' Slack: 0.08" Sump: 2" Step Position: 0°

Position	Elev	Angle	Ext. (cw)	Pipe	Pipe OD	Connector	Hole	Horz Size	Up (↓)	Offset
Invert 1	419.06'	0°	0"	8" PVC SDR26	8.5"	A-Lok 0285	9.75"	9.818"	1.125"	0"
Invert 2	423.16'	132°	66.75"	4" PVC SDR35	4.25"	Drop Tee 4" PVC	4.25"	4.256"	51.125"	0"
Invert 3	419.16'	132°	66.75"	4" PVC SDR35	4.25"	Drop Elbow 4" PVC	4.25"	4.256"	3.125"	0"
Invert 4										
Invert 5										
Invert 6										
Invert 7										
Invert 8										

RIGHT-SIDE UP VIEW (int. dimensions)

UPSIDE-DOWN VIEW (int. dimensions)

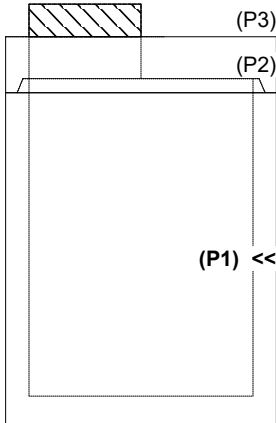
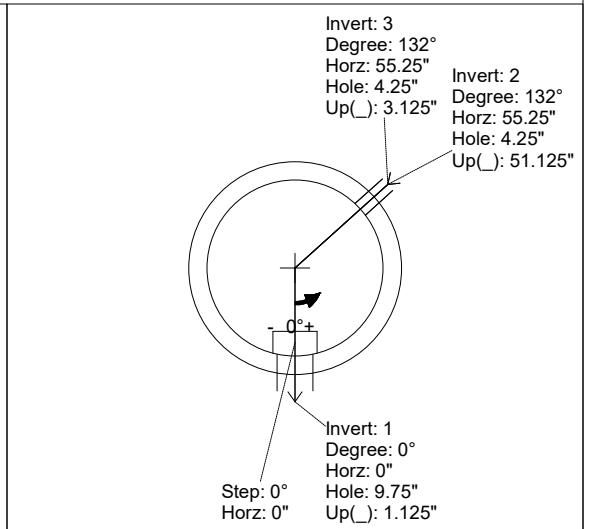
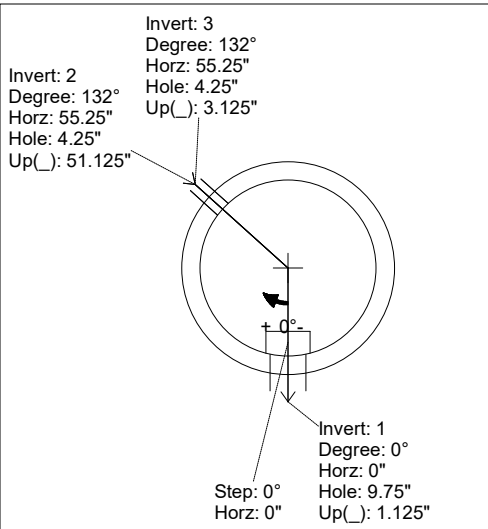

INSIDE WALL DIMENSIONS

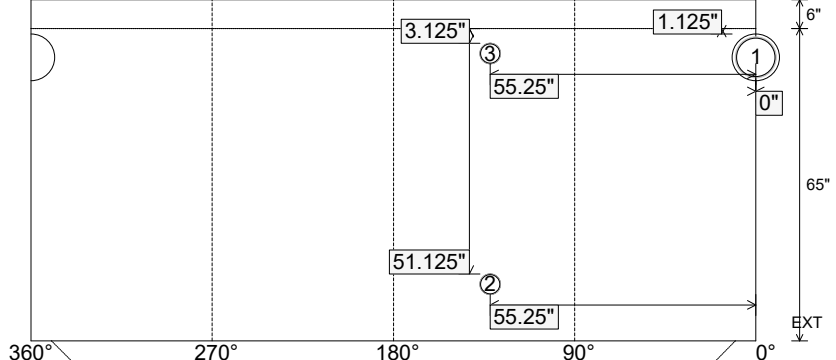

Coating (Int): Coating (Ext):	Seam Up: Tongue Seam Dn: n/a	Wall Thickness: 5" Floor Height: 6"	Height (Int): 65" Height (Ext): 71"	Weight (Net): 8888 lb Volume (Net): 2.27cu.yd
----------------------------------	---------------------------------	--	--	--

Job Name: 26-1961 - Dollar Tree  
 Job Location: Hanson, KY  
 Contractor: Steve Pleasant Excavating

Plant: 100  
 4/30/2026 12:57:27 PM

Tech: Jared - F  
 PC: E. Bradley



**Structure ID: 1 SS-MHD**

**P1 MH048BAVF-D**

**MH BASE w/DROP Custom Ht T/n**

- P3) 24" - CASTING HEIGHT - 7"
- P2) 48" - MH FLAT TOP w/ 24" ECC Hole F/G - 12"
- P1) 48" - MH BASE w/DROP Custom Ht T/n - 65"
- 1) 48" - MH INVERT CHANNEL - FULL HEIGHT
- 1) JOINT WRAP - 12" WD x 048" MAC WRAP
- 1) CASTING - HOE MC-375 F/C Sanitary
- 1) 48" - Conseal CS-102 1.00" (Double)
- 1) A-Lok - 0285
- 1) Drop Tee - 4" PVC
- 1) Drop Elbow - 4" PVC
- 5) MH Step ML-10-TDS-NCR - 10"

0 lb  
 1561 lb  
 8888 lb  
 1440 lb  
 0 lb  
 271 lb  
 0 lb  
 1 lb  
 0 lb  
 0 lb  
 0 lb  
 0 lb  
 -----  
 Structure Total: 12161 lb

Structure Notes:

1. PER ASTM C478 SPECIFICATIONS.
2. CONCRETE = 4,000 PSI AT 28 DAYS.
3. CASTING BY ICAST (HOE MC-375 F/C SANITARY),
4. EXTERIOR DROP ASSEMBLY PROVIDED BY ICAST.

REINFORCING PER ASTM A615 (GRADE 60).  
 - TOP SLAB = H20 LOADING  
 - RISER/WALLS (As .12)  
 - FLOOR (As .31) #5 BARS AT 12" C.C.E.W.

Rim: 425.9' Rim to Invert: 6.84' Slack: 0.08" Sump: 2" Step Position: 0°

Position	Elev	Angle	Ext. (cw)	Pipe	Pipe OD	Connector	Hole	Horz Size	Up (↓)	Offset
Invert 1	419.06'	0°	0"	8" PVC SDR26	8.5"	A-Lok 0285	9.75"	9.818"	1.125"	0"
Invert 2	423.16'	132°	66.75"	4" PVC SDR35	4.25"	Drop Tee 4" PVC	4.25"	4.256"	51.125"	0"
Invert 3	419.16'	132°	66.75"	4" PVC SDR35	4.25"	Drop Elbow 4" PVC	4.25"	4.256"	3.125"	0"
Invert 4										
Invert 5										
Invert 6										
Invert 7										
Invert 8										

RIGHT-SIDE UP VIEW (int. dimensions)

UPSIDE-DOWN VIEW (int. dimensions)

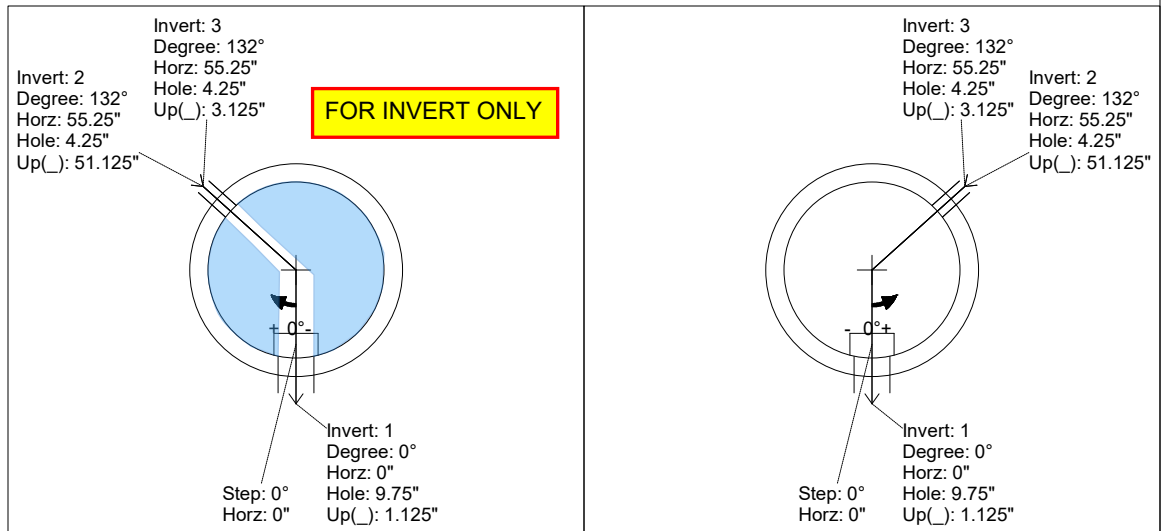

INSIDE WALL DIMENSIONS

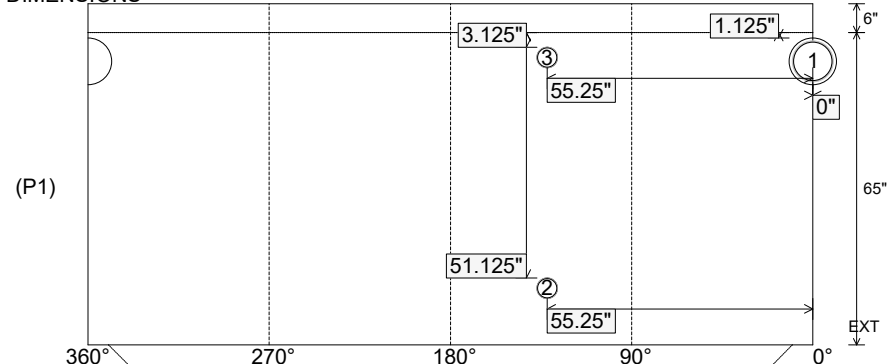

Coating (Int):  
 Coating (Ext):

Seam Up: Tongue  
 Seam Dn: n/a

Wall Thickness: 5"  
 Floor Height: 6"

Height (Int): 65"  
 Height (Ext): 71"

Weight (Net): 8888 lb  
 Volume (Net): 2.27cu.yd

Job Name: 25-1431 - Georgetown Commons  
 Job Location: Georgetown, KY  
 Contractor: Winwater Hartford KY Co.

Plant: Beaver Dam

4/28/2026 8:55:43 AM

Tech: J. Coppage

PC: A. Chambers



**Structure ID: SSMH-197**

**P1 MH048BAEVF**

**MH BASE w/FLANGE (08F/08EF)**

- P5) 24" - CASTING HEIGHT - 7"
- P4) 24" - GRADE RING - 4"
- P3) 48" - ECC CONE w/ 24" HOLE NO STEP - 42"
- P2) 48" - MH RISER NO STEPS - 72"
- P1) 48" - MH BASE w/FLANGE (08F/08EF) - 24"
- 1) JOINT WRAP - 0.065"x6"x50' CONSEAL CS212
- 1) JOINT WRAP PRIMER - CONSEAL CS-75 (1 gal.)
- 1) 48" - MH INVERT CHANNEL - FULL HEIGHT
- 2) 48" - Conseal CS-102 1.00" (Double)
- 2) A-Lok - 0285

- Structure Notes:**
1. JR HOE MC-375 SELF SEALING SAN BY ICAST
  2. PER ASTM C478 SPECIFICATIONS.
  3. CONCRETE = 4,000 PSI AT 28 DAYS.
  4. REINFORCING PER ASTM A615 (GRADE 60).
  - CONE (As .12)
  - RISER/WALLS (As .12)
  - FLOOR (As .31) #5 BARS AT 12" C.C.E.W.
  5. \*\*NO STEPS\*\*

Structure Total: 14242 lb

Rim: 877.07' Rim to Invert: 12.27' Slack: 0.24" Sump: 2" Step Position:

Position	Elev	Angle	Ext. (cw)	Pipe	Pipe OD	Connector	Hole	Horz Size	Up (")	Offset
Invert 1	864.8'	0°	0"	8" PVC SDR35	8.5"	A-Lok 0285	9.75"	9.818"	1.125"	0"
Invert 2	864.9'	167°	84.526"	8" PVC SDR35	8.5"	A-Lok 0285	9.75"	9.818"	2.325"	0"
Invert 3										
Invert 4										
Invert 5										
Invert 6										
Invert 7										
Invert 8										

RIGHT-SIDE UP VIEW (int. dimensions)

UPSIDE-DOWN VIEW (int. dimensions)

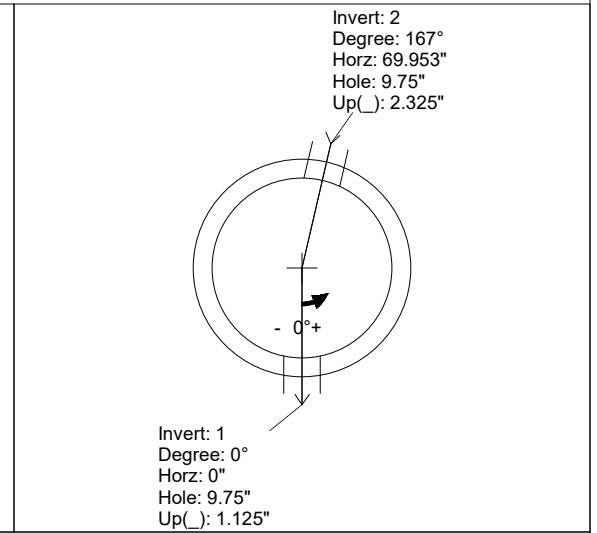
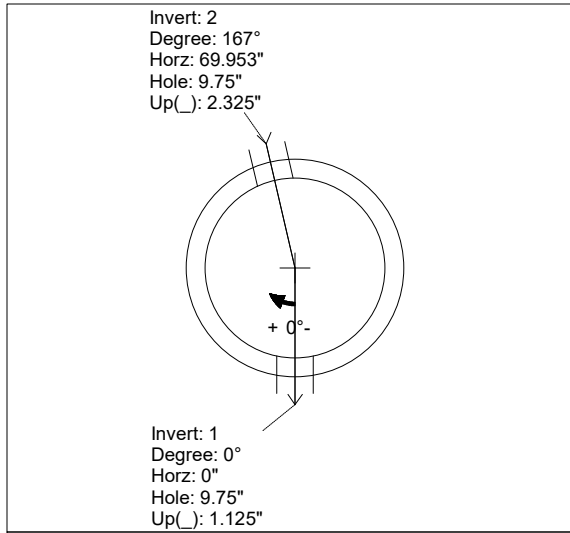
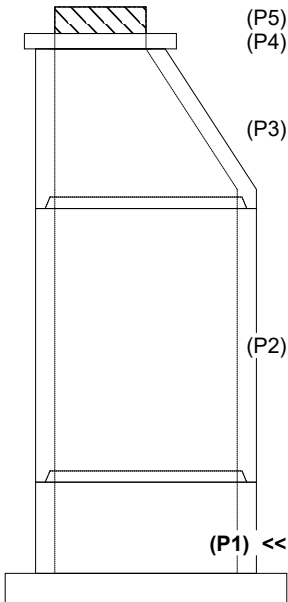

INSIDE WALL DIMENSIONS

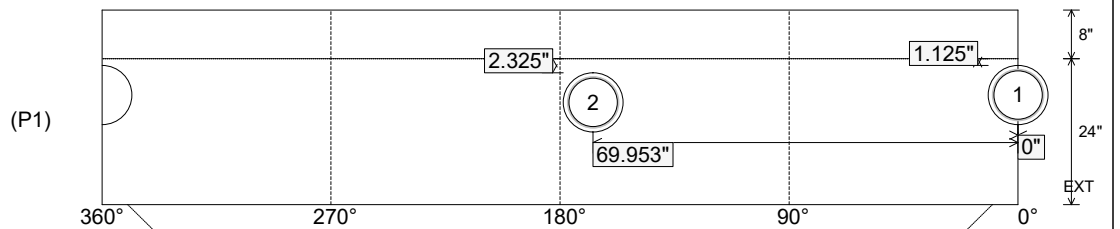

Coating (Int):  
 Coating (Ext):

Seam Up: Tongue  
 Seam Dn: n/a

Wall Thickness: 5"  
 Floor Height: 8"

Height (Int): 24"  
 Height (Ext): 32"

Weight (Net): 4501 lb  
 Volume (Net): 1.15cu.yd

Job Name: 25-1431 - Georgetown Commons  
 Job Location: Georgetown, KY  
 Contractor: Winwater Hartford KY Co.

Plant: Beaver Dam

4/28/2026 8:55:43 AM

Tech: J. Coppage

PC: A. Chambers



**Structure ID: SSMH-197**

**P1 MH048BAEVF**

**MH BASE w/FLANGE (08F/08EF)**

- P5) 24" - CASTING HEIGHT - 7"
- P4) 24" - GRADE RING - 4"
- P3) 48" - ECC CONE w/ 24" HOLE NO STEP - 42"
- P2) 48" - MH RISER NO STEPS - 72"
- P1) 48" - MH BASE w/FLANGE (08F/08EF) - 24"
- 1) JOINT WRAP - 0.065"x6"x50' CONSEAL CS212
- 1) JOINT WRAP PRIMER - CONSEAL CS-75 (1 gal.)
- 1) 48" - MH INVERT CHANNEL - FULL HEIGHT
- 2) 48" - Conseal CS-102 1.00" (Double)
- 2) A-Lok - 0285

- Structure Notes:
1. JR HOE MC-375 SELF SEALING SAN BY ICAST
  2. PER ASTM C478 SPECIFICATIONS.
  3. CONCRETE = 4,000 PSI AT 28 DAYS.
  4. REINFORCING PER ASTM A615 (GRADE 60).
  - CONE (As .12)
  - RISER/WALLS (As .12)
  - FLOOR (As .31) #5 BARS AT 12" C.C.E.W.
  5. \*\*NO STEPS\*\*

Structure Total: 14242 lb

**INVERT CHANNEL DRAWING  
 FULL HEIGHT INVERT**

Rim: 877.07' Rim to Invert: 12.27' Slack: 0.24" Sump: 2" Step Position:

Position	Elev	Angle	Ext. (cw)	Pipe	Pipe OD	Connector	Hole	Horz Size	Up (")	Offset
Invert 1	864.8'	0°	0"	8" PVC SDR35	8.5"	A-Lok 0285	9.75"	9.818"	1.125"	0"
Invert 2	864.9'	167°	84.526"	8" PVC SDR35	8.5"	A-Lok 0285	9.75"	9.818"	2.325"	0"
Invert 3										
Invert 4										
Invert 5										
Invert 6										
Invert 7										
Invert 8										

RIGHT-SIDE UP VIEW (int. dimensions)

UPSIDE-DOWN VIEW (int. dimensions)

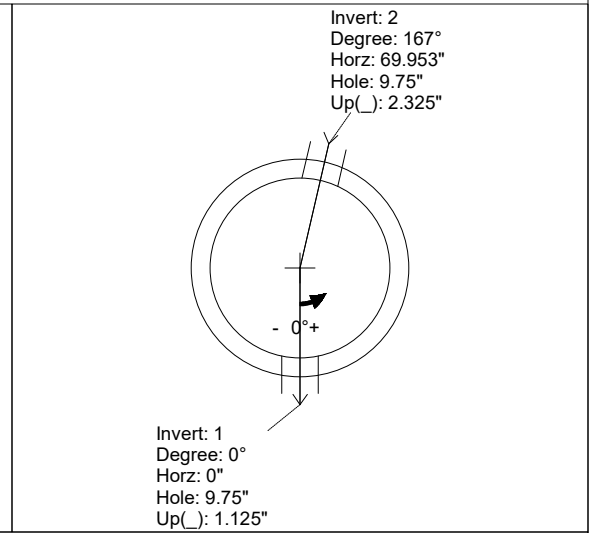
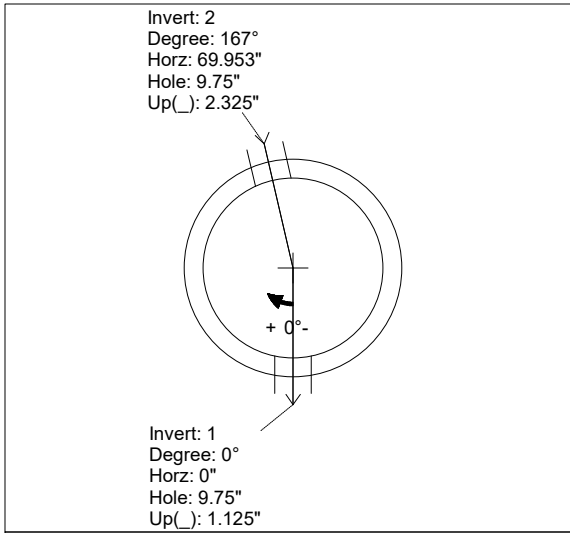
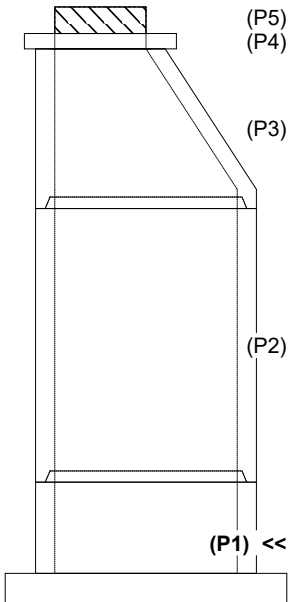

INSIDE WALL DIMENSIONS

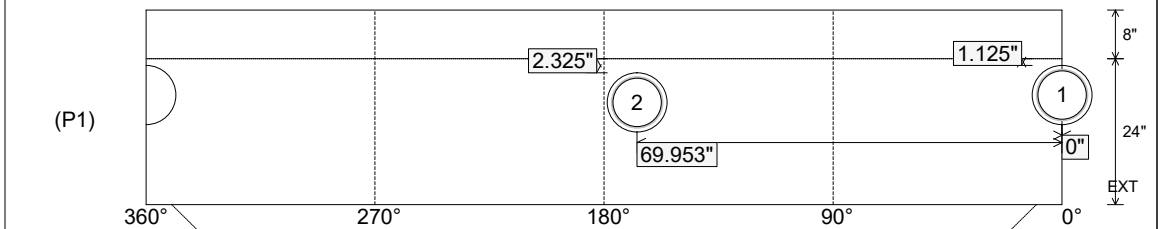

Coating (Int):  
 Coating (Ext):

Seam Up: Tongue  
 Seam Dn: n/a

Wall Thickness: 5"  
 Floor Height: 8"

Height (Int): 24"  
 Height (Ext): 32"

Weight (Net): 4501 lb  
 Volume (Net): 1.15cu.yd

Job Name: 25-1431 - Georgetown Commons  
 Job Location: Georgetown, KY  
 Contractor: Winwater Hartford KY Co.

Plant: Beaver Dam

4/28/2026 8:55:41 AM

Tech: J. Copping

PC: A. Chambers



**Structure ID: SSMH-194**

**P1 MH048BAEVF**

**MH BASE w/FLANGE (08F/08EF)**

- P4) 24" - CASTING HEIGHT - 7"
- P3) 48" - ECC CONE w/ 24" HOLE NO STEP - 30"
- P2) 48" - MH RISER NO STEPS - 60"
- P1) 48" - MH BASE w/FLANGE (08F/08EF) - 24"
- 1) JOINT WRAP - 0.065"x6"x50' CONSEAL CS212
- 1) JOINT WRAP PRIMER - CONSEAL CS-75 (1 gal.)
- 1) 48" - MH INVERT CHANNEL - FULL HEIGHT
- 2) 48" - Conseal CS-102 1.00" (Double)
- 2) A-Lok - 0285

- Structure Notes:**
1. JR HOE MC-375 SELF SEALING SAN BY ICAST
  2. PER ASTM C478 SPECIFICATIONS.
  3. CONCRETE = 4,000 PSI AT 28 DAYS.
  4. REINFORCING PER ASTM A615 (GRADE 60).  
 - CONE (As .12)  
 - RISER/WALLS (As .12)  
 - FLOOR (As .31) #5 BARS AT 12" C.C.E.W.
  5. \*\*NO STEPS\*\*

Structure Total: 12184 lb

Rim: 868.94' Rim to Invert: 10.02' Slack: 1.24" Sump: 2" Step Position:

Position	Elev	Angle	Ext. (cw)	Pipe	Pipe OD	Connector	Hole	Horz Size	Up (")	Offset
Invert 1	858.92'	0°	0"	8" PVC SDR35	8.5"	A-Lok 0285	9.75"	9.818"	1.125"	0"
Invert 2	859.02'	90°	45.553"	8" PVC SDR35	8.5"	A-Lok 0285	9.75"	9.818"	2.325"	0"
Invert 3										
Invert 4										
Invert 5										
Invert 6										
Invert 7										
Invert 8										

RIGHT-SIDE UP VIEW (int. dimensions)

UPSIDE-DOWN VIEW (int. dimensions)

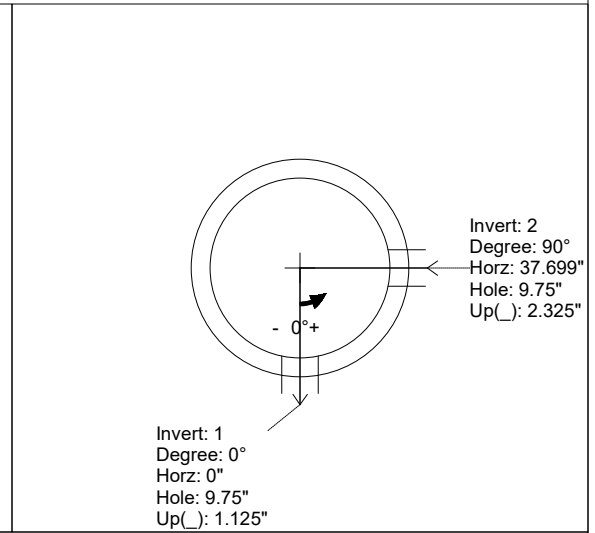
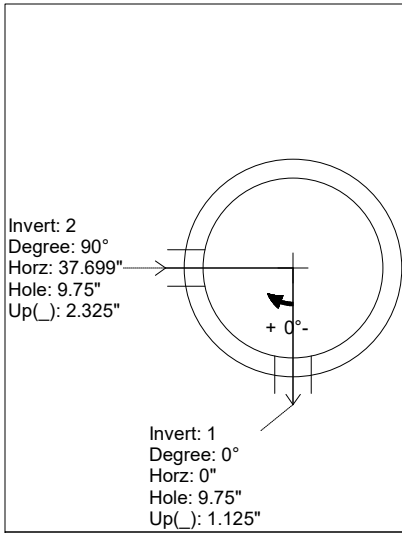
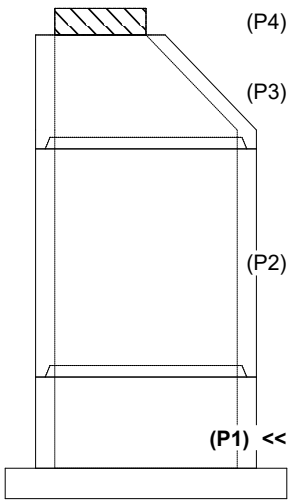

INSIDE WALL DIMENSIONS

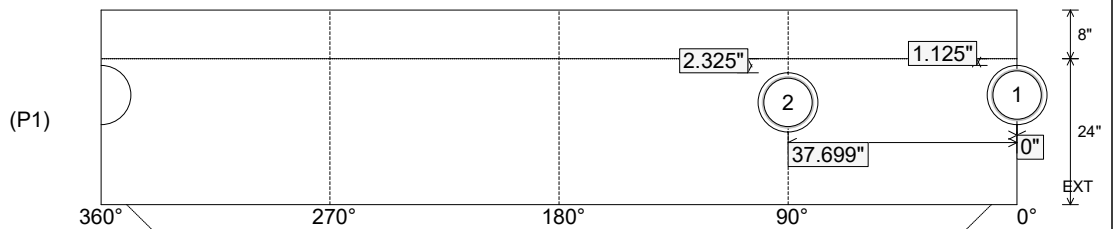

Coating (Int):  
 Coating (Ext):

Seam Up: Tongue  
 Seam Dn: n/a

Wall Thickness: 5"  
 Floor Height: 8"

Height (Int): 24"  
 Height (Ext): 32"

Weight (Net): 4501 lb  
 Volume (Net): 1.15cu.yd

Job Name: 25-1431 - Georgetown Commons  
 Job Location: Georgetown, KY  
 Contractor: Winwater Hartford KY Co.

Plant: Beaver Dam

4/28/2026 8:55:41 AM

Tech: J. Coppage

PC: A. Chambers



**Structure ID: SSMH-194**

**P1 MH048BAEVF**

**MH BASE w/FLANGE (08F/08EF)**

- P4) 24" - CASTING HEIGHT - 7"
- P3) 48" - ECC CONE w/ 24" HOLE NO STEP - 30"
- P2) 48" - MH RISER NO STEPS - 60"
- P1) 48" - MH BASE w/FLANGE (08F/08EF) - 24"
- 1) JOINT WRAP - 0.065"x6"x50' CONSEAL CS212
- 1) JOINT WRAP PRIMER - CONSEAL CS-75 (1 gal.)
- 1) 48" - MH INVERT CHANNEL - FULL HEIGHT
- 2) 48" - Conseal CS-102 1.00" (Double)
- 2) A-Lok - 0285

- Structure Notes:**
1. JR HOE MC-375 SELF SEALING SAN BY ICAST
  2. PER ASTM C478 SPECIFICATIONS.
  3. CONCRETE = 4,000 PSI AT 28 DAYS.
  4. REINFORCING PER ASTM A615 (GRADE 60).  
 - CONE (As .12)  
 - RISER/WALLS (As .12)  
 - FLOOR (As .31) #5 BARS AT 12" C.C.E.W.
  5. \*\*NO STEPS\*\*

Structure Total: 12184 lb

**INVERT CHANNEL DRAWING  
 FULL HEIGHT INVERT**

Rim: 868.94' Rim to Invert: 10.02' Slack: 1.24" Sump: 2" Step Position:

Position	Elev	Angle	Ext. (cw)	Pipe	Pipe OD	Connector	Hole	Horz Size	Up (")	Offset
Invert 1	858.92'	0°	0"	8" PVC SDR35	8.5"	A-Lok 0285	9.75"	9.818"	1.125"	0"
Invert 2	859.02'	90°	45.553"	8" PVC SDR35	8.5"	A-Lok 0285	9.75"	9.818"	2.325"	0"
Invert 3										
Invert 4										
Invert 5										
Invert 6										
Invert 7										
Invert 8										

RIGHT-SIDE UP VIEW (int. dimensions)

UPSIDE-DOWN VIEW (int. dimensions)

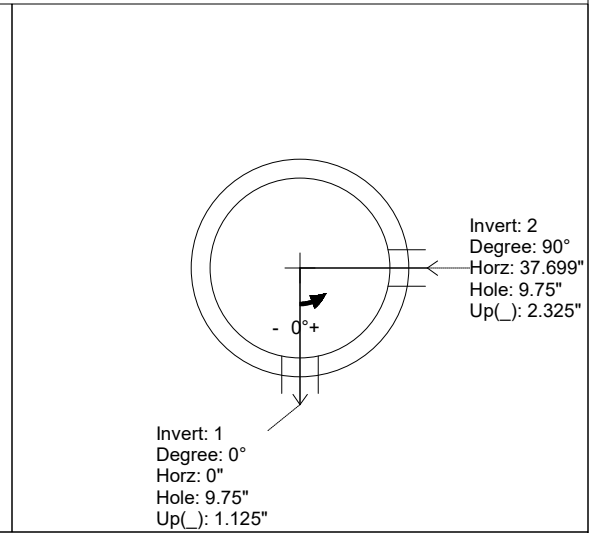
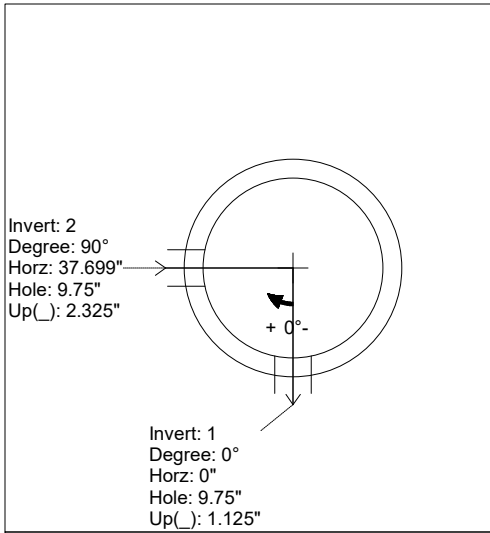
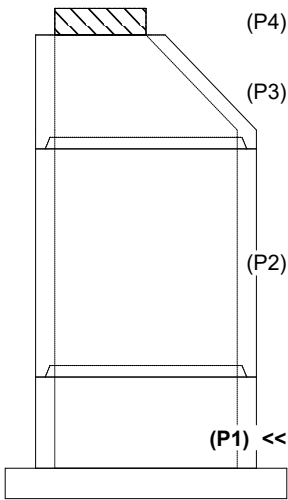

INSIDE WALL DIMENSIONS

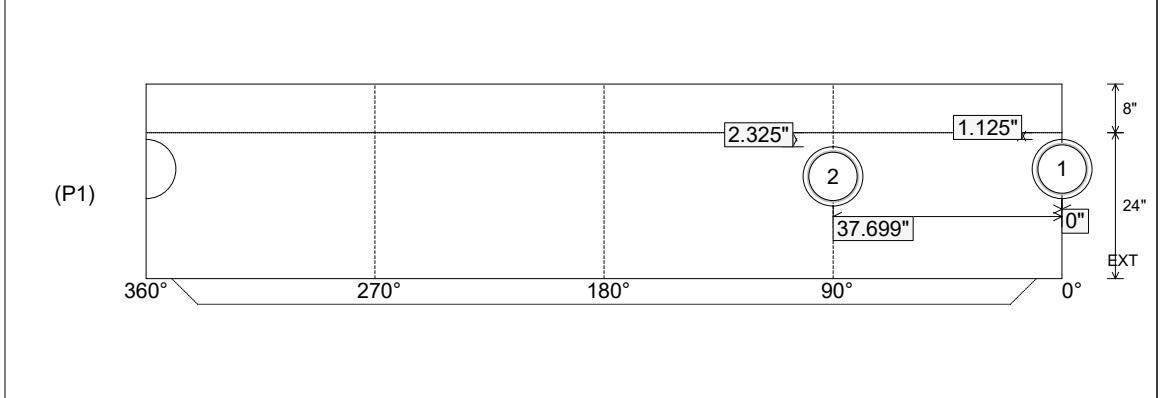

Coating (Int): Coating (Ext):	Seam Up: Tongue Seam Dn: n/a	Wall Thickness: 5" Floor Height: 8"	Height (Int): 24" Height (Ext): 32"	Weight (Net): 4501 lb Volume (Net): 1.15cu.yd
----------------------------------	---------------------------------	--	--	--

Job Name: 25-1431 - Georgetown Commons  
 Job Location: Georgetown, KY  
 Contractor: Winwater Hartford KY Co.

Plant: Beaver Dam

Tech: J. Coppage

4/28/2026 8:57:04 AM

PC: A. Chambers



**Structure ID: SSMH-194**

**P2 MH048RS60S**

**MH RISER NO STEPS**

- P4) 24" - CASTING HEIGHT - 7"
- P3) 48" - ECC CONE w/ 24" HOLE NO STEP - 30"
- P2) 48" - MH RISER NO STEPS - 60"
- P1) 48" - MH BASE w/FLANGE (08F/08EF) - 24"
- 1) JOINT WRAP - 0.065"x6"x50' CONSEAL CS212
- 1) JOINT WRAP PRIMER - CONSEAL CS-75 (1 gal.)
- 1) 48" - MH INVERT CHANNEL - FULL HEIGHT
- 2) 48" - Conseal CS-102 1.00" (Double)
- 2) A-Lok - 0285

- Structure Notes:**
1. JR HOE MC-375 SELF SEALING SAN BY ICAST
  2. PER ASTM C478 SPECIFICATIONS.
  3. CONCRETE = 4,000 PSI AT 28 DAYS.
  4. REINFORCING PER ASTM A615 (GRADE 60).  
 - CONE (As .12)  
 - RISER/WALLS (As .12)  
 - FLOOR (As .31) #5 BARS AT 12" C.C.E.W.
  5. \*\*NO STEPS\*\*

Structure Total: 12184 lb

Rim: 868.94' Rim to Invert: 10.02' Slack: 1.24" Sump: 2" Step Position:

Position	Elev	Angle	Ext. (cw)	Pipe	Pipe OD	Connector	Hole	Horz Size	Up (L)	Offset
Invert 1										
Invert 2										
Invert 3										
Invert 4										
Invert 5										
Invert 6										
Invert 7										
Invert 8										

**RIGHT-SIDE UP VIEW (int. dimensions)**

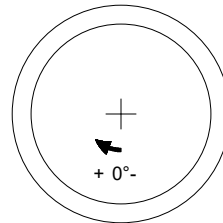
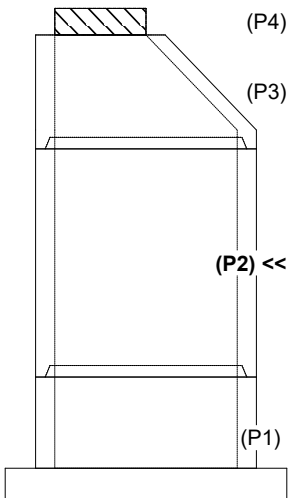

**INSIDE WALL DIMENSIONS**

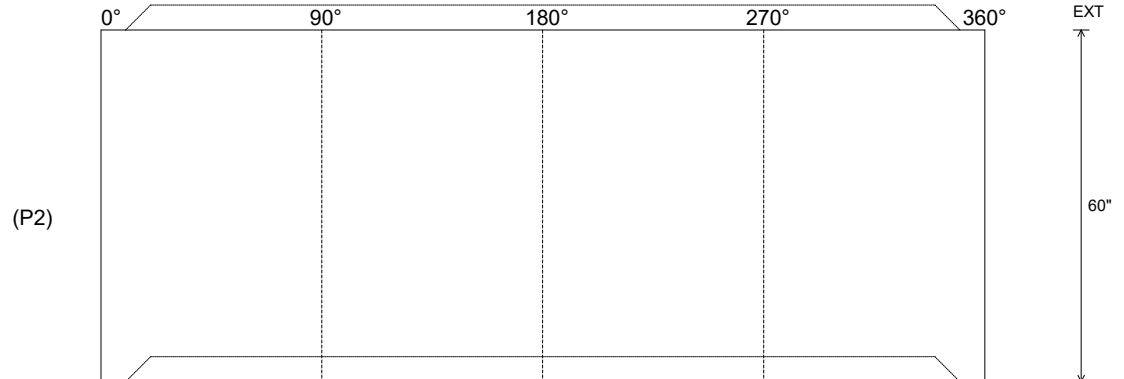

Coating (Int): Coating (Ext):	Seam Up: Tongue Seam Dn: Groove	Wall Thickness: 5" Floor Height: 0"	Height (Int): 60" Height (Ext): 60"	Weight (Net): 4192 lb Volume (Net): 1.07cu.yd
----------------------------------	------------------------------------	--	--	--

Job Name: 25-1431 - Georgetown Commons  
 Job Location: Georgetown, KY  
 Contractor: Winwater Hartford KY Co.

Plant: Beaver Dam

4/28/2026 8:57:05 AM

Tech: J. Coppage

PC: A. Chambers



**Structure ID: SSMH-196**

**P2 MH048RS48S**

**MH RISER NO STEPS**

- P4) 24" - CASTING HEIGHT - 7"
- P3) 48" - ECC CONE w/ 24" HOLE NO STEP - 30"
- P2) 48" - MH RISER NO STEPS - 48"
- P1) 48" - MH BASE - 24"
- 1) JOINT WRAP - 0.065"x6"x50' CONSEAL CS212
- 1) JOINT WRAP PRIMER - CONSEAL CS-75 (1 gal.)
- 1) 48" - MH INVERT CHANNEL - FULL HEIGHT
- 2) 48" - Conseal CS-102 1.00" (Double)
- 2) A-Lok - 0285

- Structure Notes:**
1. JR HOE MC-375 SELF SEALING SAN BY ICAST
  2. PER ASTM C478 SPECIFICATIONS.
  3. CONCRETE = 4,000 PSI AT 28 DAYS.
  4. REINFORCING PER ASTM A615 (GRADE 60).  
 - CONE (As .12)  
 - RISER/WALLS (As .12)  
 - FLOOR (As .31) #5 BARS AT 12" C.C.E.W.
  5. \*\*NO STEPS\*\*

0 lb  
 2050 lb  
 3353 lb  
 2944 lb  
 0 lb  
 0 lb  
 1440 lb  
 0 lb  
 2 lb  
 -----  
 Structure Total: 9789 lb

Structure Total:

Rim: 871.98' Rim to Invert: 9.08' Slack: 1.96" Sump: 2" Step Position:

Position	Elev	Angle	Ext. (cw)	Pipe	Pipe OD	Connector	Hole	Horz Size	Up (L)	Offset
Invert 1										
Invert 2										
Invert 3										
Invert 4										
Invert 5										
Invert 6										
Invert 7										
Invert 8										

**RIGHT-SIDE UP VIEW (int. dimensions)**

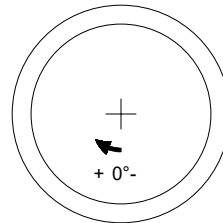
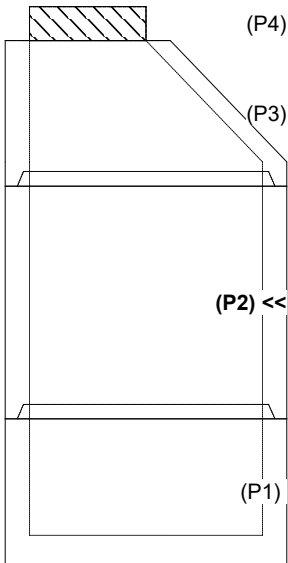

**INSIDE WALL DIMENSIONS**

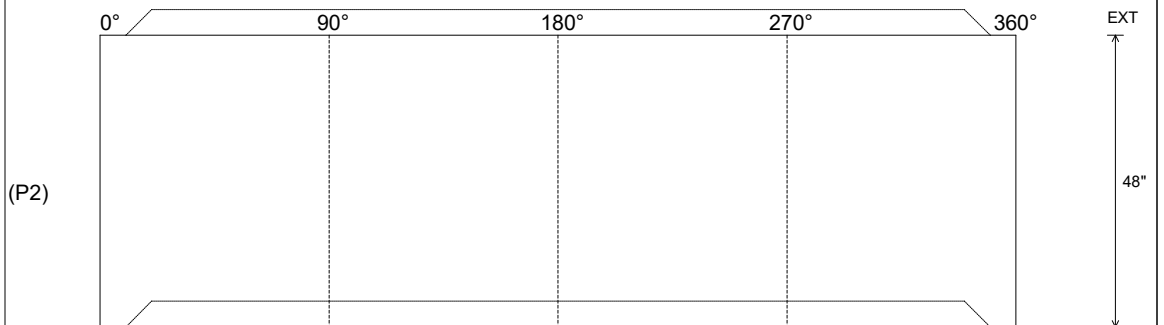

Coating (Int): Coating (Ext):	Seam Up: Tongue Seam Dn: Groove	Wall Thickness: 5" Floor Height: 0"	Height (Int): 48" Height (Ext): 48"	Weight (Net): 3353 lb Volume (Net): 0.86cu.yd
----------------------------------	------------------------------------	--	--	--

Job Name: 25-1431 - Georgetown Commons  
 Job Location: Georgetown, KY  
 Contractor: Winwater Hartford KY Co.

Plant: Beaver Dam

4/28/2026 8:57:04 AM

Tech: J. Copping

PC: A. Chambers



**Structure ID: SSMH-195**

**P2 MH048RS48S**

**MH RISER NO STEPS**

- P5) 24" - CASTING HEIGHT - 7"
- P4) 24" - GRADE RING - 3"
- P3) 48" - ECC CONE w/ 24" HOLE NO STEP - 30"
- P2) 48" - MH RISER NO STEPS - 48"
- P1) 48" - MH BASE - 24"
- 1) JOINT WRAP - 0.065"x6"x50' CONSEAL CS212
- 1) JOINT WRAP PRIMER - CONSEAL CS-75 (1 gal.)
- 1) 48" - MH INVERT CHANNEL - FULL HEIGHT
- 2) 48" - Conseal CS-102 1.00" (Double)
- 2) A-Lok - 0285
- 1) A-Lok - 0200

- Structure Notes:**
1. JR HOE MC-375 SELF SEALING SAN BY ICAST
  2. PER ASTM C478 SPECIFICATIONS.
  3. CONCRETE = 4,000 PSI AT 28 DAYS.
  4. REINFORCING PER ASTM A615 (GRADE 60).  
 - CONE (As .12)  
 - RISER/WALLS (As .12)  
 - FLOOR (As .31) #5 BARS AT 12" C.C.E.W.
  5. \*\*NO STEPS\*\*

0 lb  
 202 lb  
 2050 lb  
 3353 lb  
 2928 lb  
 0 lb  
 0 lb  
 1440 lb  
 0 lb  
 2 lb  
 1 lb

Structure Total: 9976 lb

Rim: 870.02' Rim to Invert: 9.21' Slack: 0.52" Sump: 2" Step Position:

Position	Elev	Angle	Ext. (cw)	Pipe	Pipe OD	Connector	Hole	Horz Size	Up (L)	Offset
Invert 1										
Invert 2										
Invert 3										
Invert 4										
Invert 5										
Invert 6										
Invert 7										
Invert 8										

**RIGHT-SIDE UP VIEW (int. dimensions)**

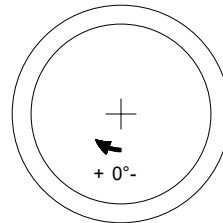
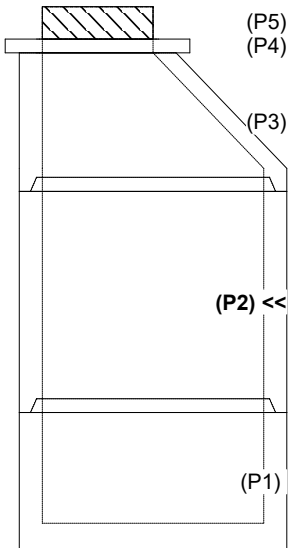

**INSIDE WALL DIMENSIONS**

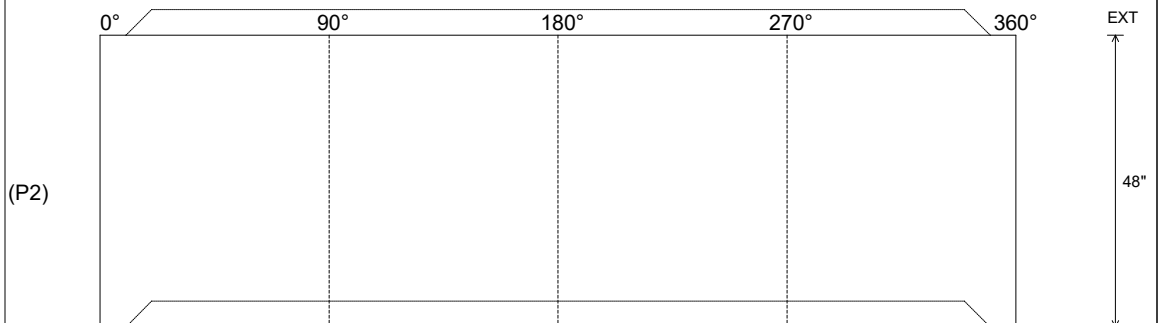

Coating (Int):  
 Coating (Ext):

Seam Up: Tongue  
 Seam Dn: Groove

Wall Thickness: 5"  
 Floor Height: 0"

Height (Int): 48"  
 Height (Ext): 48"

Weight (Net): 3353 lb  
 Volume (Net): 0.86cu.yd

Job Name: 26-1210 Sacramento Gravity Sewer  
 Job Location: Sacramento, KY  
 Contractor: Scott & Ritter, Inc.

Plant: Beaver Dam  
 4/23/2026 8:35:43 AM

Tech: S. Felletter  
 PC: T. Lewis



**Structure ID: CMH5-23 SS-MH**

**P1 MH048BA36**

**MH BASE T/n**

- P3) 24" - CASTING HEIGHT - 7"
- P2) 48" - ECC CONE w/ 24" HOLE F/G - 42"
- P1) 48" - MH BASE T/n - 36"

- 1) JOINT WRAP - 0.065"x6"x50' CONSEAL CS212
- 1) JOINT WRAP PRIMER - CONSEAL CS-75 (1 gal.)
- 1) 48" - MH INVERT CHANNEL - FULL HEIGHT
- 1) 48" - Conseal CS-102 1.00" (Double)
- 2) PSX - 12-08 DD (DBL Bands)
- 6) MH Step ML-10-TDS-NCR - 10"

0 lb  
 3200 lb  
 3749 lb  
 0 lb  
 0 lb  
 1440 lb  
 0 lb  
 16 lb  
 0 lb  
 -----  
 Structure Total: 8405 lb

Structure Notes:

1. PER ASTM C478 SPECIFICATIONS.
2. CONCRETE = 4,000 PSI AT 28 DAYS.
3. CASTING BY OTHERS.

REINFORCING PER ASTM A615 (GRADE 60).

- CONE (As .12)
- RISER/WALLS (As .12)
- FLOOR (As .31) #5 BARS AT 12" C.C.E.W.

Rim: 495.08' Rim to Invert: 7.14' Slack: 2.68" Sump: 2" Step Position: 0°

Position	Elev	Angle	Ext. (cw)	Pipe	Pipe OD	Connector	Hole	Horz Size	Up ( )	Offset
Invert 1	487.94'	0°	0"	8" PVC SDR35	8.5"	PSX 12-08 DD (DBL Bands)	12"	12.129"	0"	0"
Invert 2	488.04'	178°	90.094"	8" PVC SDR35	8.5"	PSX 12-08 DD (DBL Bands)	12"	12.129"	1.2"	0"
Invert 3										
Invert 4										
Invert 5										
Invert 6										
Invert 7										
Invert 8										

RIGHT-SIDE UP VIEW (int. dimensions)

UPSIDE-DOWN VIEW (int. dimensions)

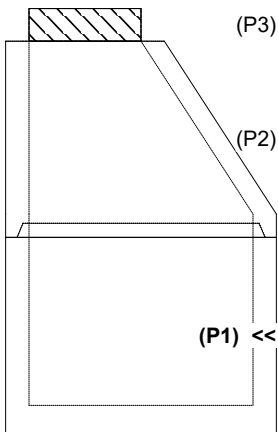
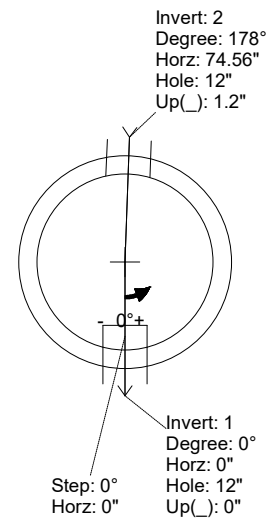
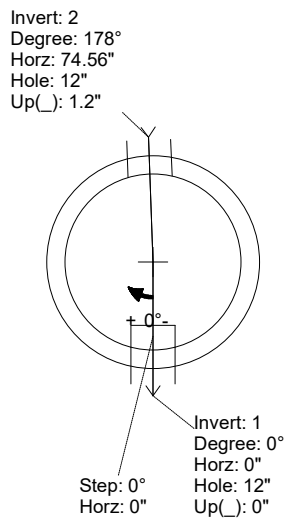

INSIDE WALL DIMENSIONS

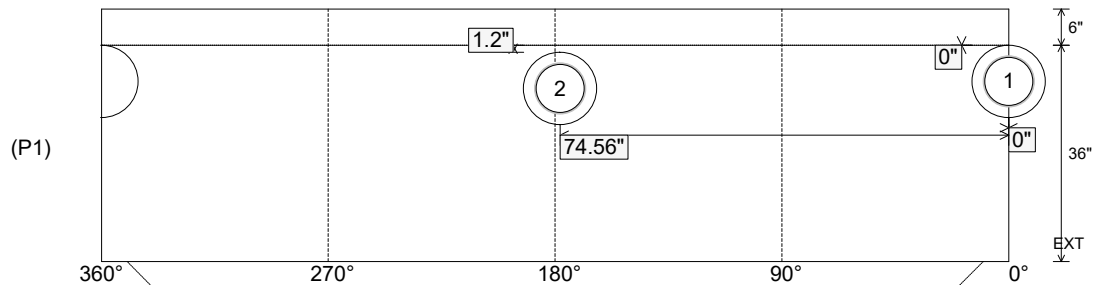

Coating (Int):  
 Coating (Ext):

Seam Up: Tongue  
 Seam Dn: n/a

Wall Thickness: 5"  
 Floor Height: 6"

Height (Int): 36"  
 Height (Ext): 42"

Weight (Net): 3749 lb  
 Volume (Net): 0.96cu.yd

Job Name: 26-1210 Sacramento Gravity Sewer  
 Job Location: Sacramento, KY  
 Contractor: Scott & Ritter, Inc.

Plant: Beaver Dam  
 4/23/2026 8:35:43 AM

Tech: S. Felletter  
 PC: T. Lewis



**Structure ID: CMH5-23 SS-MH**

**P1 MH048BA36**

**MH BASE T/n**

- P3) 24" - CASTING HEIGHT - 7"
- P2) 48" - ECC CONE w/ 24" HOLE F/G - 42"
- P1) 48" - MH BASE T/n - 36"
- 1) JOINT WRAP - 0.065"x6"x50' CONSEAL CS212
- 1) JOINT WRAP PRIMER - CONSEAL CS-75 (1 gal.)
- 1) 48" - MH INVERT CHANNEL - FULL HEIGHT
- 1) 48" - Conseal CS-102 1.00" (Double)
- 2) PSX - 12-08 DD (DBL Bands)
- 6) MH Step ML-10-TDS-NCR - 10"

0 lb  
 3200 lb  
 3749 lb  
 0 lb  
 0 lb  
 1440 lb  
 0 lb  
 16 lb  
 0 lb  
 -----  
 Structure Total: 8405 lb

**Structure Notes:**  
 1. PER ASTM C478 SPECIFICATIONS.  
 2. CONCRETE = 4,000 PSI AT 28 DAYS.  
 3. CASTING BY OTHERS.  
  
 REINFORCING PER ASTM A615 (GRADE 60).  
 - CONE (As .12)  
 - RISER/WALLS (As .12)  
 - FLOOR (As .31) #5 BARS AT 12" C.C.E.W.

**Invert channel drawing - full height invert**

Rim: 495.08' Rim to Invert: 7.14' Slack: 2.68" Sump: 2" Step Position: 0°

Position	Elev	Angle	Ext. (cw)	Pipe	Pipe OD	Connector	Hole	Horz Size	Up ( )	Offset
Invert 1	487.94'	0°	0"	8" PVC SDR35	8.5"	PSX 12-08 DD (DBL Bands)	12"	12.129"	0"	0"
Invert 2	488.04'	178°	90.094"	8" PVC SDR35	8.5"	PSX 12-08 DD (DBL Bands)	12"	12.129"	1.2"	0"
Invert 3										
Invert 4										
Invert 5										
Invert 6										
Invert 7										
Invert 8										

RIGHT-SIDE UP VIEW (int. dimensions)

UPSIDE-DOWN VIEW (int. dimensions)

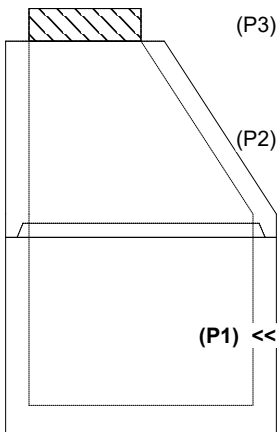
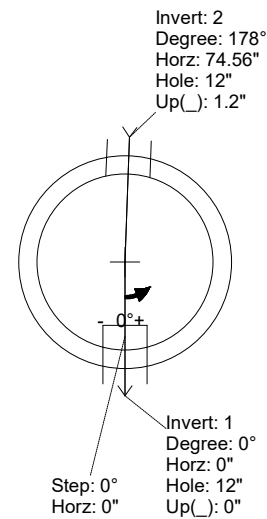
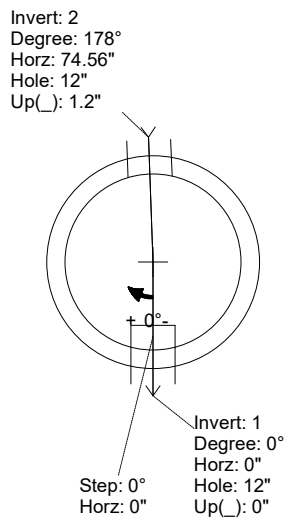

INSIDE WALL DIMENSIONS

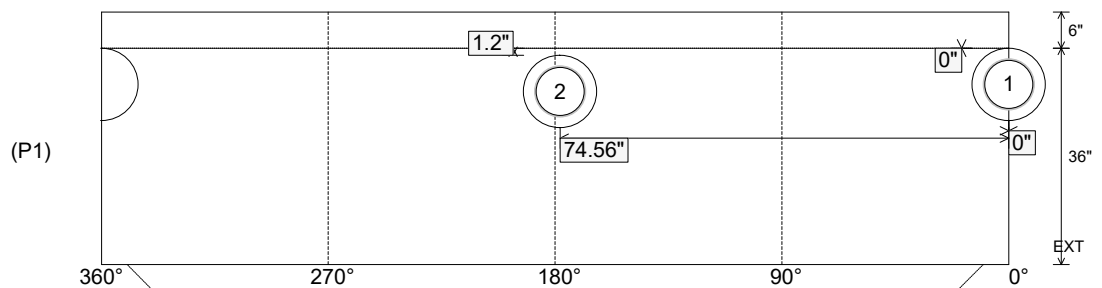

Coating (Int):  
 Coating (Ext):

Seam Up: Tongue  
 Seam Dn: n/a

Wall Thickness: 5"  
 Floor Height: 6"

Height (Int): 36"  
 Height (Ext): 42"

Weight (Net): 3749 lb  
 Volume (Net): 0.96cu.yd

Job Name: 26-1210 Sacramento Gravity Sewer  
 Job Location: Sacramento, KY  
 Contractor: Scott & Ritter, Inc.

Plant: Beaver Dam  
 4/23/2026 8:35:42 AM

Tech: S. Felletter  
 PC: T. Lewis



**Structure ID: CMH4-22 SS-MH**

**P1 MH048BA42**

**MH BASE T/n**

- P4) 24" - CASTING HEIGHT - 7"
- P3) 48" - ECC CONE w/ 24" HOLE F/G - 24"
- P2) 48" - MH RISER T/G - 36"
- P1) 48" - MH BASE T/n - 42"
- 1) JOINT WRAP - 0.065"x6"x50' CONSEAL CS212
- 1) JOINT WRAP PRIMER - CONSEAL CS-75 (1 gal.)
- 1) 48" - MH INVERT CHANNEL - FULL HEIGHT
- 2) 48" - Conseal CS-102 1.00" (Double)
- 3) PSX - 12-08 DD (DBL Bands)
- 8) MH Step ML-10-TDS-NCR - 10"

0 lb  
 1550 lb  
 2515 lb  
 4121 lb  
 0 lb  
 0 lb  
 1440 lb  
 0 lb  
 24 lb  
 0 lb  
 -----  
 Structure Total: 9650 lb

Structure Notes:

1. PER ASTM C478 SPECIFICATIONS.
2. CONCRETE = 4,000 PSI AT 28 DAYS.
3. CASTING BY OTHERS.

REINFORCING PER ASTM A615 (GRADE 60).

- CONE (As .12)
- RISER/WALLS (As .12)
- FLOOR (As .31) #5 BARS AT 12" C.C.E.W.

Rim: 496' Rim to Invert: 8.99' Slack: 0.88' Sump: 2" Step Position: 0°

Position	Elev	Angle	Ext. (cw)	Pipe	Pipe OD	Connector	Hole	Horz Size	Up ( )	Offset
Invert 1	487.01'	0°	0"	8" PVC SDR35	8.5"	PSX 12-08 DD (DBL Bands)	12"	12.129"	0"	0"
Invert 2	487.11'	180°	91.106"	8" PVC SDR35	8.5"	PSX 12-08 DD (DBL Bands)	12"	12.129"	1.2"	0"
Invert 3	489.01'	270°	136.659"	8" PVC SDR35	8.5"	PSX 12-08 DD (DBL Bands)	12"	12.129"	24"	0"
Invert 4										
Invert 5										
Invert 6										
Invert 7										
Invert 8										

RIGHT-SIDE UP VIEW (int. dimensions)

UPSIDE-DOWN VIEW (int. dimensions)

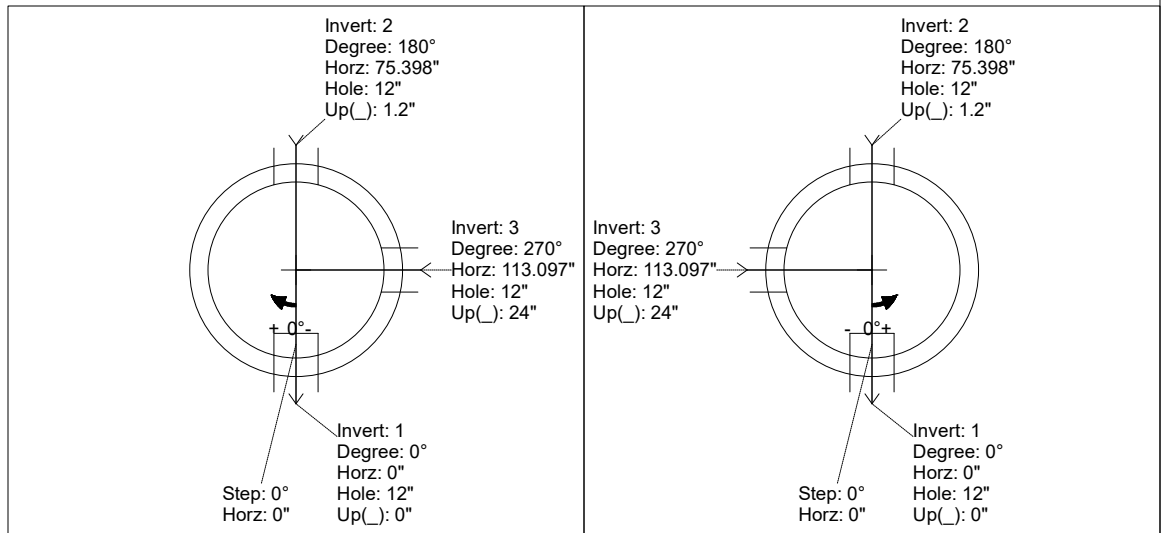
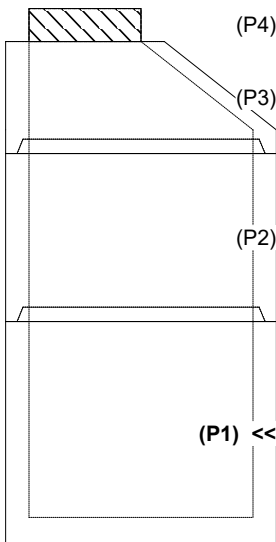

INSIDE WALL DIMENSIONS

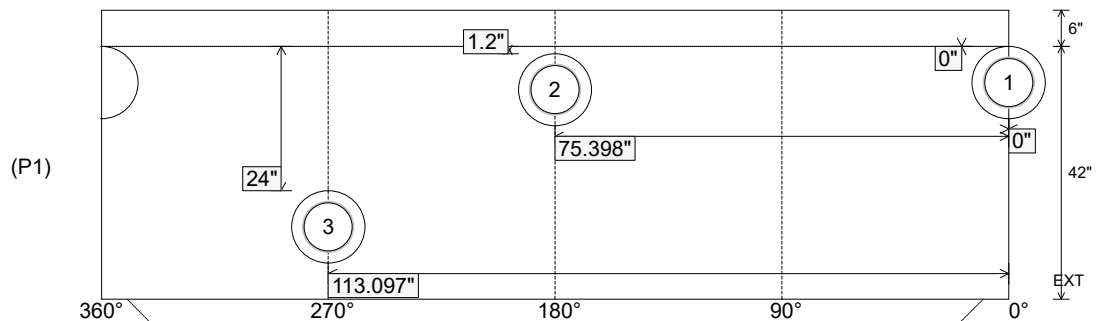

Coating (Int):  
 Coating (Ext):

Seam Up: Tongue  
 Seam Dn: n/a

Wall Thickness: 5"  
 Floor Height: 6"

Height (Int): 42"  
 Height (Ext): 48"

Weight (Net): 4121 lb  
 Volume (Net): 1.05cu.yd

Job Name: 26-1210 Sacramento Gravity Sewer  
 Job Location: Sacramento, KY  
 Contractor: Scott & Ritter, Inc.

Plant: Beaver Dam  
 4/23/2026 8:35:42 AM

Tech: S. Felletter  
 PC: T. Lewis



**Structure ID: CMH4-22 SS-MH**

**P1 MH048BA42**

**MH BASE T/n**

- P4) 24" - CASTING HEIGHT - 7"
- P3) 48" - ECC CONE w/ 24" HOLE F/G - 24"
- P2) 48" - MH RISER T/G - 36"
- P1) 48" - MH BASE T/n - 42"
- 1) JOINT WRAP - 0.065"x6"x50' CONSEAL CS212
- 1) JOINT WRAP PRIMER - CONSEAL CS-75 (1 gal.)
- 1) 48" - MH INVERT CHANNEL - FULL HEIGHT
- 2) 48" - Conseal CS-102 1.00" (Double)
- 3) PSX - 12-08 DD (DBL Bands)
- 8) MH Step ML-10-TDS-NCR - 10"

0 lb  
 1550 lb  
 2515 lb  
 4121 lb  
 0 lb  
 0 lb  
 1440 lb  
 0 lb  
 24 lb  
 0 lb  
 -----  
 Structure Total: 9650 lb

Structure Notes:

1. PER ASTM C478 SPECIFICATIONS.
2. CONCRETE = 4,000 PSI AT 28 DAYS.
3. CASTING BY OTHERS.

REINFORCING PER ASTM A615 (GRADE 60).

- CONE (As .12)
- RISER/WALLS (As .12)
- FLOOR (As .31) #5 BARS AT 12" C.C.E.W.

**Invert channel drawing - full height invert**

Rim: 496' Rim to Invert: 8.99' Slack: 0.88" Sump: 2" Step Position: 0°

Position	Elev	Angle	Ext. (cw)	Pipe	Pipe OD	Connector	Hole	Horz Size	Up ( )	Offset
Invert 1	487.01'	0°	0"	8" PVC SDR35	8.5"	PSX 12-08 DD (DBL Bands)	12"	12.129"	0"	0"
Invert 2	487.11'	180°	91.106"	8" PVC SDR35	8.5"	PSX 12-08 DD (DBL Bands)	12"	12.129"	1.2"	0"
Invert 3	489.01'	270°	136.659"	8" PVC SDR35	8.5"	PSX 12-08 DD (DBL Bands)	12"	12.129"	24"	0"
Invert 4										
Invert 5										
Invert 6										
Invert 7										
Invert 8										

RIGHT-SIDE UP VIEW (int. dimensions)

UPSIDE-DOWN VIEW (int. dimensions)

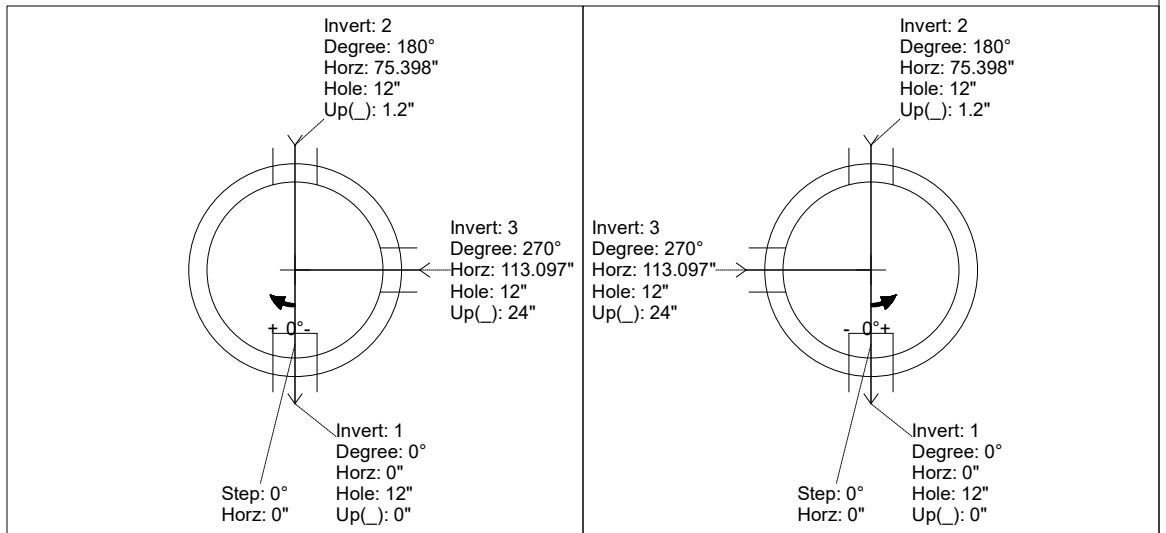
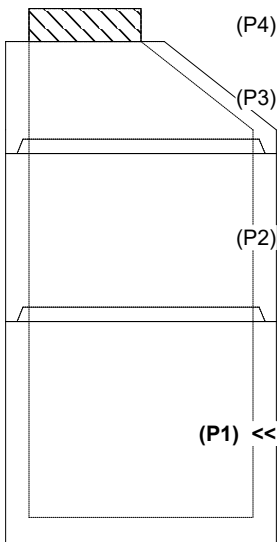

INSIDE WALL DIMENSIONS

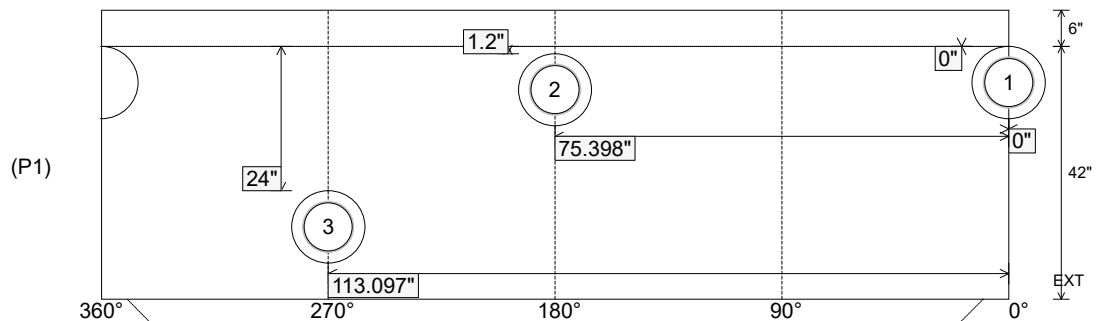

Coating (Int):  
 Coating (Ext):

Seam Up: Tongue  
 Seam Dn: n/a

Wall Thickness: 5"  
 Floor Height: 6"

Height (Int): 42"  
 Height (Ext): 48"

Weight (Net): 4121 lb  
 Volume (Net): 1.05cu.yd

Job Name: 26-1232 - Mustang Village Apartments Ph.1  
 Job Location: Paducah, KY  
 Contractor: Wood Brothers

Plant: 100  
 4/21/2026 8:04:31 PM

Tech: Jared - F  
 PC: T. Lewis



**Structure ID: S24-24 ST-DBI**

**P2 MH048LD07SP**

**MH FLAT TOP w/24"x24" Hole F/F**

- P3) 24" x 24" - CASTING HEIGHT - 0"
- P2) 48" - MH FLAT TOP w/24"x24" Hole F/F - 7"
- P1) 48" - MH BASE Custom Ht F/n - 29"
- 1) CASTING - HOE HOE-315 ANGLE F/G
- 1) 48" - Conseal CS-102 1.00"
- 1) 24" x 24" - Conseal CS-102 1.00"
- 2) Hole - 24

0 lb  
 1214 lb  
 2962 lb  
 258 lb  
 0 lb  
 0 lb  
 0 lb  
 0 lb  
 -----  
 Structure Total: 4433 lb

**Structure Notes:**  
 1. PER ASTM C478 SPECIFICATIONS.  
 2. CONCRETE = 4,000 PSI AT 28 DAYS.  
 3. NO STEPS AND NO INVERT CHANNEL.  
 4. CASTING BY ICAST (HOE-315 ANGLE F/G).

REINFORCING PER ASTM A615 (GRADE 60).  
 - TOP SLAB (As .62) #5 BARS AT 6" C.C.E.W..  
 - RISER/WALLS (As .12)  
 - FLOOR (As .31) #5 BARS AT 12" C.C.E.W.

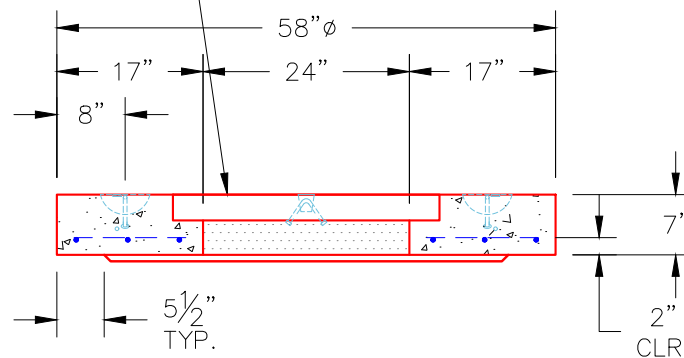
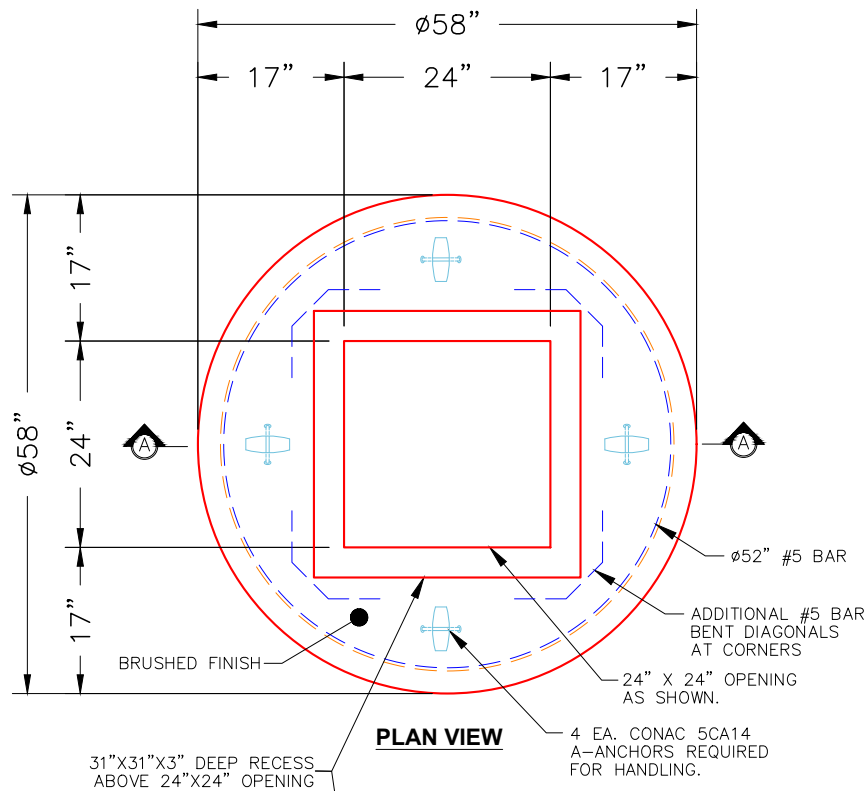

- NOTES:**
1. MANUFACTURED TO ASTM C-478 (LATEST REVISION).
  2. CONCRETE: 4,000 PSI AT 28 DAYS.
  3. REINFORCING: #5 BAR @ 6" O.C. E.W. (GRADE 60).

Coating (Int):  
 Coating (Ext):

Seam Up: Flat  
 Seam Dn: Flat

Wall Thickness: 5"

Height (Ext): 7"

Weight (Net): 1214 lb  
 Volume (Net): 0.31cu.yd

Job Name: 26-1232 - Mustang Village Apartments Ph.1  
 Job Location: Paducah, KY  
 Contractor: Wood Brothers

Plant: 100  
 4/21/2026 8:03:13 PM

Tech: Jared - F  
 PC: T. Lewis



**Structure ID: S23-23 ST-DBI**

**P1 MH048BA36**

**MH BASE T/n**

- P3) 24" x 24" - CASTING HEIGHT - 0"
- P2) 48" - MH FLAT TOP w/24"x24" Hole F/G - 12"
- P1) 48" - MH BASE T/n - 36"
- 1) CASTING - HOE HOE-315 ANGLE F/G
- 1) 48" - Conseal CS-102 1.00"
- 1) 24" x 24" - Conseal CS-102 1.00"
- 2) Hole - 24

0 lb  
 1500 lb  
 3451 lb  
 258 lb  
 0 lb  
 0 lb  
 0 lb  
 -----  
 Structure Total: 5209 lb

**Structure Notes:**  
 1. PER ASTM C478 SPECIFICATIONS.  
 2. CONCRETE = 4,000 PSI AT 28 DAYS.  
 3. NO STEPS AND NO INVERT CHANNEL.  
 4. CASTING BY ICAST (HOE-315 ANGLE F/G).  
 REINFORCING PER ASTM A615 (GRADE 60).  
 - TOP SLAB (As .62) #5 BARS AT 6" C.C.E.W..  
 - RISER/WALLS (As .12)  
 - FLOOR (As .31) #5 BARS AT 12" C.C.E.W.

Rim: 378.5' Rim to Invert: 4.05' Slack: 0.6" Sump: 0" Step Position:

Position	Elev	Angle	Ext. (cw)	Pipe	Pipe OD	Connector	Hole	Horz Size	Up ( )	Offset
Invert 1	374.45'	0°	0"	18" HDPE	21.2"	Hole 24	24"	25.133"	-1.625"	0"
Invert 2	374.45'	192°	97.125"	18" HDPE	21.2"	Hole 24	24"	25.133"	-1.625"	0"
Invert 3										
Invert 4										
Invert 5										
Invert 6										
Invert 7										
Invert 8										

RIGHT-SIDE UP VIEW (int. dimensions)

UPSIDE-DOWN VIEW (int. dimensions)

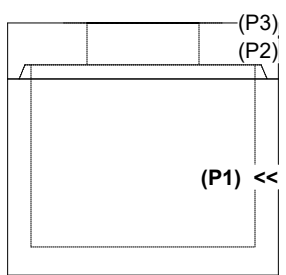
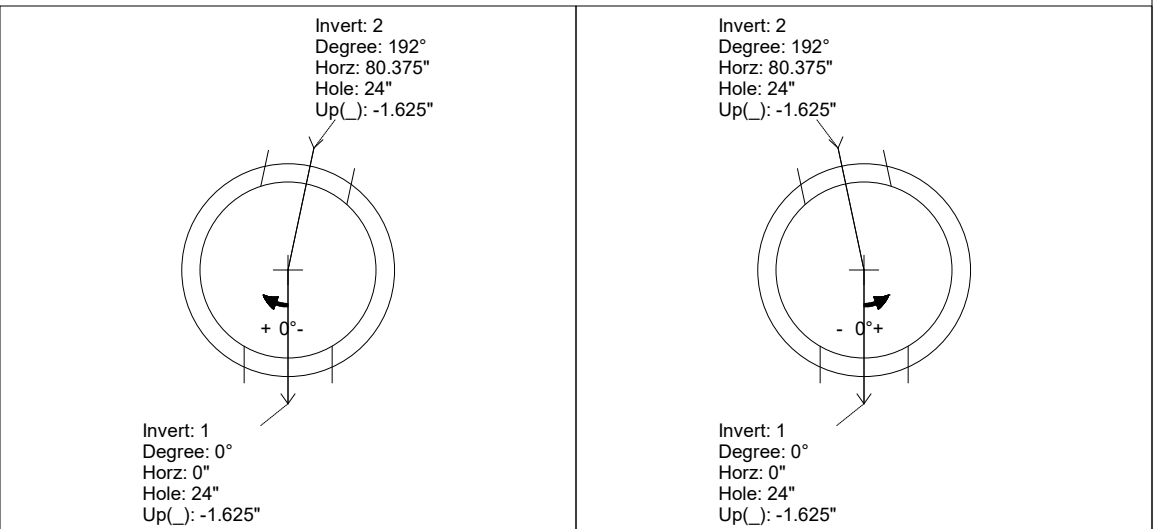

INSIDE WALL DIMENSIONS

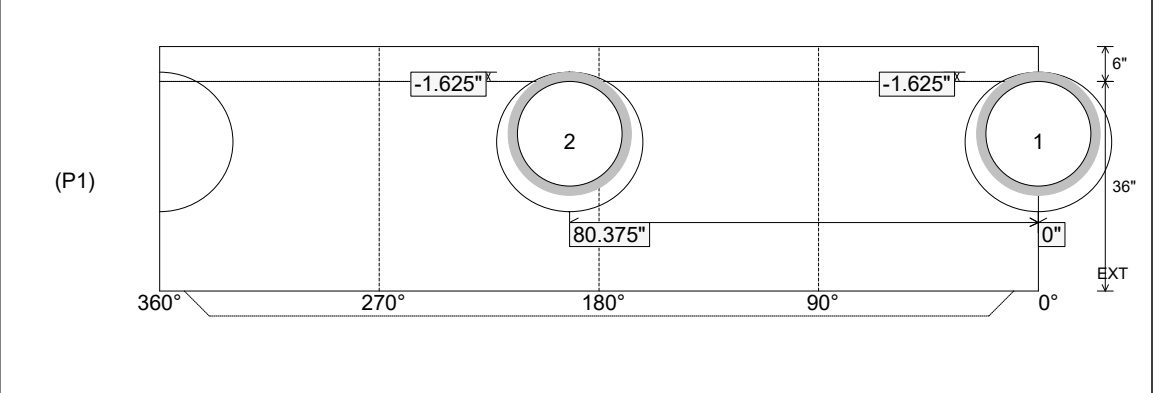

Coating (Int): Coating (Ext):	Seam Up: Tongue Seam Dn: n/a	Wall Thickness: 5" Floor Height: 6"	Height (Int): 36" Height (Ext): 42"	Weight (Net): 3451 lb Volume (Net): 0.88cu.yd
----------------------------------	---------------------------------	--	--	--

Job Name: 26-1232 - Mustang Village Apartments Ph.1  
 Job Location: Paducah, KY  
 Contractor: Wood Brothers

Plant: 100  
 4/21/2026 8:03:13 PM

Tech: Jared - F  
 PC: T. Lewis



**Structure ID: S22-22 ST-DBI**

**P1 MH048BAVF**

**MH BASE Custom Ht T/n**

- P3) 24" x 24" - CASTING HEIGHT - 0"
- P2) 48" - MH FLAT TOP w/24"x24" Hole F/G - 12"
- P1) 48" - MH BASE Custom Ht T/n - 34"
- 1) CASTING - HOE HOE-315 ANGLE F/G
- 1) 48" - Conseal CS-102 1.00"
- 1) 24" x 24" - Conseal CS-102 1.00"
- 2) Hole - 24"

0 lb  
 1500 lb  
 3311 lb  
 258 lb  
 0 lb  
 0 lb  
 0 lb  
 -----  
 Structure Total: 5069 lb

**Structure Notes:**  
 1. PER ASTM C478 SPECIFICATIONS.  
 2. CONCRETE = 4,000 PSI AT 28 DAYS.  
 3. NO STEPS AND NO INVERT CHANNEL.  
 4. CASTING BY ICAST (HOE-315 ANGLE F/G).  
 REINFORCING PER ASTM A615 (GRADE 60).  
 - TOP SLAB (As .62) #5 BARS AT 6" C.C.E.W..  
 - RISER/WALLS (As .12)  
 - FLOOR (As .31) #5 BARS AT 12" C.C.E.W.

Rim: 376.5' Rim to Invert: 3.87' Slack: 0.44" Sump: 0" Step Position:

Position	Elev	Angle	Ext. (cw)	Pipe	Pipe OD	Connector	Hole	Horz Size	Up ( )	Offset
Invert 1	372.63'	0°	0"	18" HDPE	21.2"	Hole 24	24"	25.133"	-1.625"	0"
Invert 2	372.63'	245°	124"	18" HDPE	21.2"	Hole 24	24"	25.133"	-1.625"	0"
Invert 3										
Invert 4										
Invert 5										
Invert 6										
Invert 7										
Invert 8										

RIGHT-SIDE UP VIEW (int. dimensions)

UPSIDE-DOWN VIEW (int. dimensions)

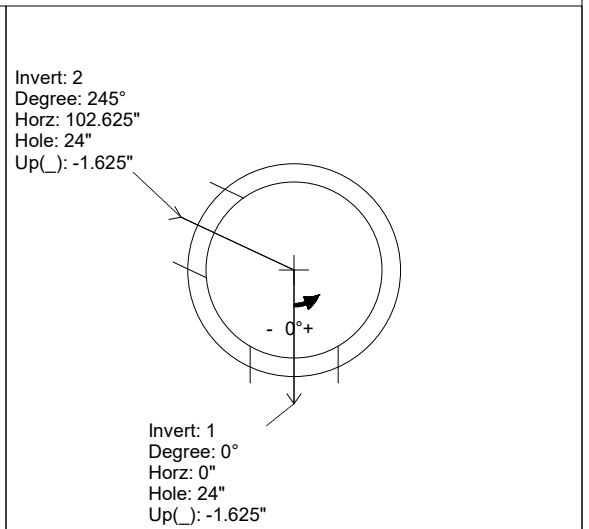
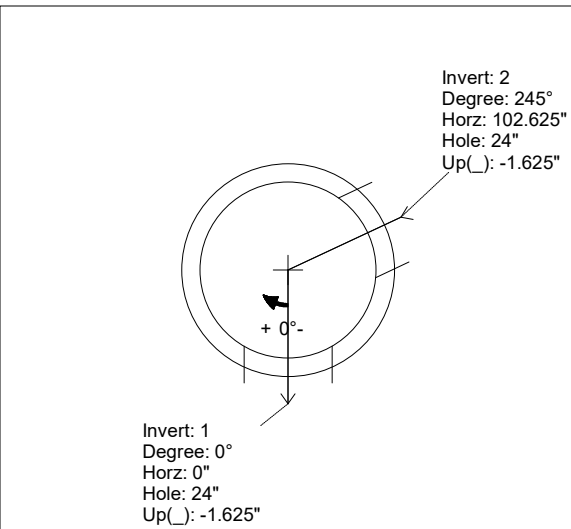
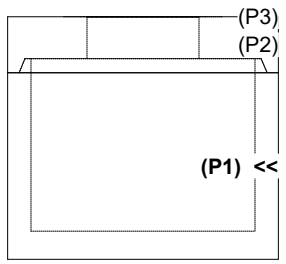

INSIDE WALL DIMENSIONS

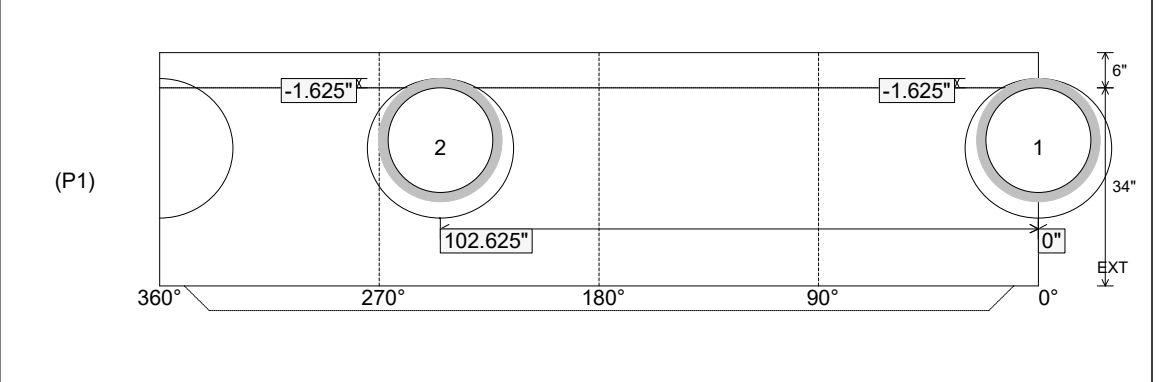

Coating (Int): Coating (Ext):	Seam Up: Tongue Seam Dn: n/a	Wall Thickness: 5" Floor Height: 6"	Height (Int): 34" Height (Ext): 40"	Weight (Net): 3311 lb Volume (Net): 0.85cu.yd
----------------------------------	---------------------------------	--	--	--

Job Name: 25-1431 - Georgetown Commons  
 Job Location: Georgetown, KY  
 Contractor: Winwater Hartford KY Co.

Plant: Beaver Dam

4/23/2026 11:20:27 AM

Tech: J. Coppage

PC: A. Chambers



**Structure ID: DCI 141**

**P1 MH048BA66**

**MH BASE**

- P4) 24" x 36" - CASTING HEIGHT - 6"
- P3) 48" - MH FLAT TOP w/24"x36" Hole - 12"
- P2) 48" - MH RISER - 12"
- P1) 48" - MH BASE - 66"
- 1) CASTING - HOE 470 SET (F/G/H)
- 2) 48" - SGL 1"x14.5' Butyl (2x)
- 2) Hole - 30
- 6) MH Step ML-10-TDS-NCR - 10"

- Structure Notes:**
1. JR HOE HOE-470 PROVIDED BY ICAST.
  2. PER ASTM C478 SPECIFICATIONS.
  3. CONCRETE = 4,000 PSI AT 28 DAYS.
  4. REINFORCING PER ASTM A615 (GRADE 60).
    - TOP SLAB (As .62) #5 BARS AT 6" C.C.E.W..
    - RISER/WALLS (As .18)
    - FLOOR (As .37) #5 BARS AT 10" C.C.E.W.

Structure Total: 7841 lb

Rim: 872' Rim to Invert: 8' Slack: 1.9" Sump: 1.9" Step Position: 227.5°

Position	Elev	Angle	Ext. (cw)	Pipe	Pipe OD	Connector	Hole	Horz Size	Up ( )	Offset
Invert 1	864'	0°	0"	24" HDPE	27.8"	Hole 30	30"	32.406"	0"	0"
Invert 2	864'	95°	48.084"	24" HDPE	27.8"	Hole 30	30"	32.406"	0"	0"
Invert 3										
Invert 4										
Invert 5										
Invert 6										
Invert 7										
Invert 8										

RIGHT-SIDE UP VIEW (int. dimensions)

UPSIDE-DOWN VIEW (int. dimensions)

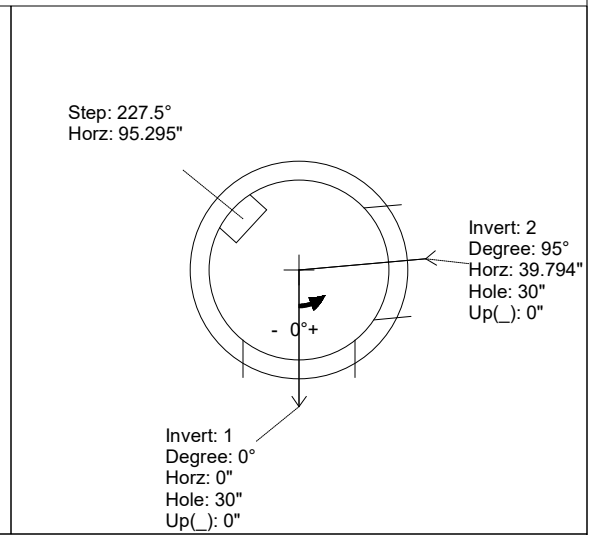
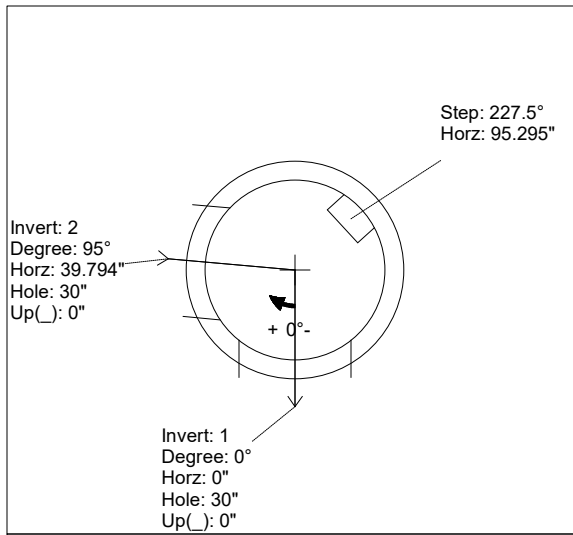
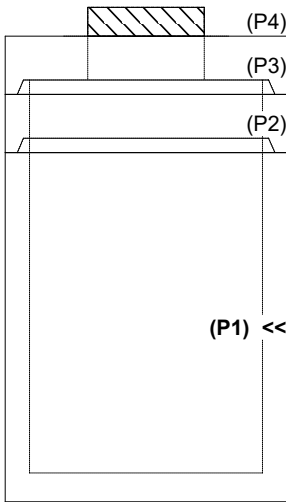

INSIDE WALL DIMENSIONS

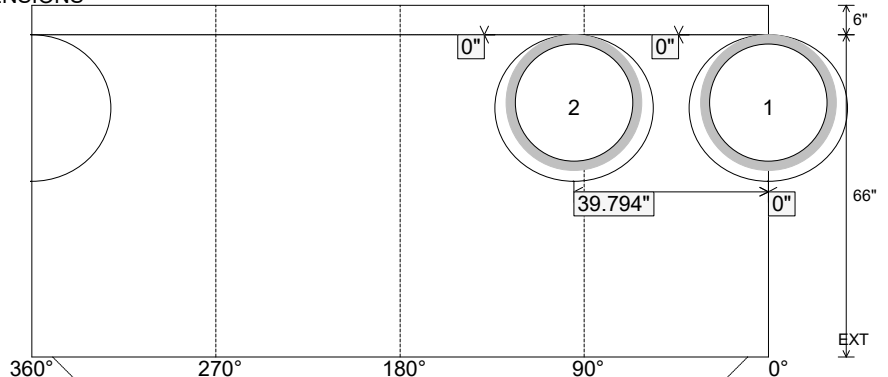

Coating (Int):  
 Coating (Ext):

Seam Up: Tongue  
 Seam Dn: n/a

Wall Thickness: 5"  
 Floor Height: 6"

Height (Int): 66"  
 Height (Ext): 72"

Weight (Net): 5309 lb  
 Volume (Net): 1.36cu.yd

Job Name: 25-1431 - Georgetown Commons  
 Job Location: Georgetown, KY  
 Contractor: Winwater Hartford KY Co.

Plant: Beaver Dam

4/23/2026 11:20:19 AM

Tech: J. Coppage

PC: A. Chambers



**Structure ID: YD 130**

**P1 MH048BA54**

**MH BASE**

- P3) 24" x 24" - CASTING HEIGHT - 4"
- P2) 48" - MH FLAT TOP w/24"x24" Hole - 12"
- P1) 48" - MH BASE - 54"
- 1) CASTING - HOE 280T F/G
- 1) 48" - Conseal CS-102 1.00"
- 1) 24" x 24" - Conseal CS-102 1.00"
- 1) Hole - 18"

- Structure Notes:**
1. JR HOE HOE-280T PROVIDED BY ICAST.
  2. PER ASTM C478 SPECIFICATIONS.
  3. CONCRETE = 4,000 PSI AT 28 DAYS.
  4. REINFORCING PER ASTM A615 (GRADE 60).
    - TOP SLAB (As .62) #5 BARS AT 6" C.C.E.W..
    - RISER/WALLS (As .12)
    - FLOOR (As .31) #5 BARS AT 12" C.C.E.W.

Structure Total: 6676 lb

Rim: 874.75' Rim to Invert: 5.75' Slack: 0.25" Sump: 1.25" Step Position:

Position	Elev	Angle	Ext. (cw)	Pipe	Pipe OD	Connector	Hole	Horz Size	Up ( )	Offset
Invert 1	869'	316°	159.942"	12" HDPE	14.5"	Hole 18	18"	18.451"	0"	0"
Invert 2										
Invert 3										
Invert 4										
Invert 5										
Invert 6										
Invert 7										
Invert 8										

RIGHT-SIDE UP VIEW (int. dimensions)

UPSIDE-DOWN VIEW (int. dimensions)

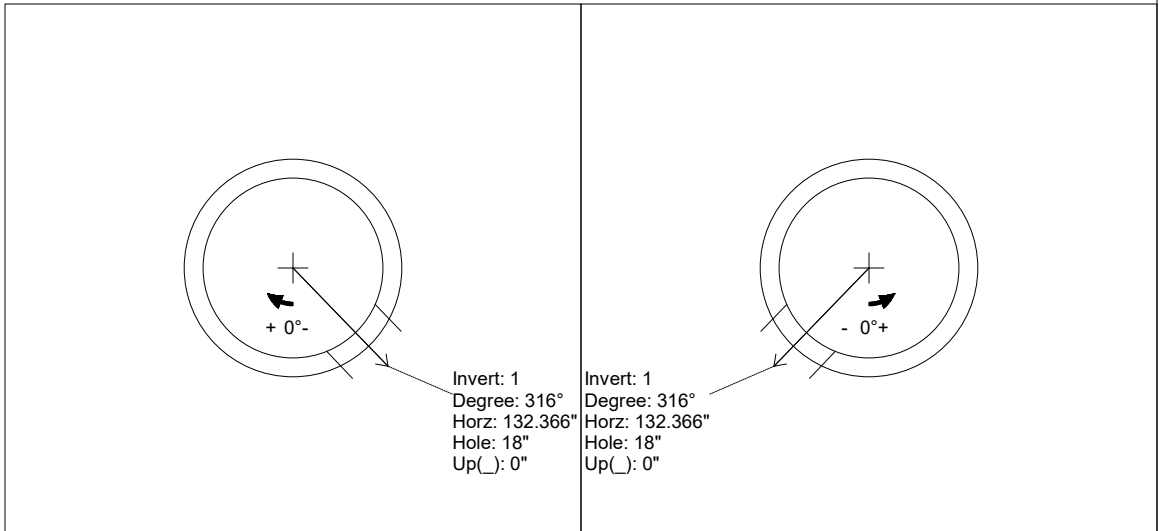
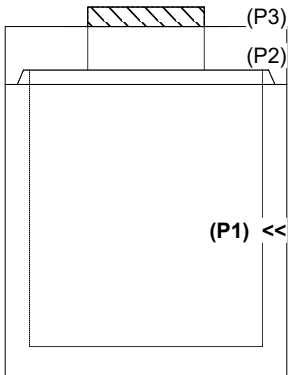

INSIDE WALL DIMENSIONS



Coating (Int):  
 Coating (Ext):

Seam Up: Tongue  
 Seam Dn: n/a

Wall Thickness: 5"  
 Floor Height: 6"

Height (Int): 54"  
 Height (Ext): 60"

Weight (Net): 4994 lb  
 Volume (Net): 1.27cu.yd

Job Name: 26-1487 - Ford LAP  
 Job Location: Louisville, KY  
 Contractor: Barton Malow Company

Plant: 100

5/6/2026 8:48:28 AM

Tech: J. Horsley

PC: E. Bradley



**Structure ID: TY 1 DHMH EAST SIDE**

**P3 MH060LD13**

**MH FLAT TOP w/ 24" ECC Hole F/G**

- P4) 24" - CASTING HEIGHT - 7"
- P3) 60" - MH FLAT TOP w/ 24" ECC Hole F/G - 13"
- P2) 60" - MH RISER T/G - 60"
- P1) 60" - MH DH RISER Custom Ht T/F - 51"
- 1) JOINT WRAP - 0.065"x6"x50" CONSEAL CS212
- 1) JOINT WRAP PRIMER - CONSEAL CS-75 (1 gal.)
- 1) CASTING - HOE WT-420-MSD F/C Storm
- 2) 60" - Conseal CS-102 1.00" (Double)
- 2) DOGHOUSE - 34"x35"
- 1) PSX - 16M NYLO
- 9) MH Step ML-10-TDS-NCR - 10"

0 lb  
 2869 lb  
 6264 lb  
 4092 lb  
 0 lb  
 0 lb  
 340 lb  
 0 lb  
 0 lb  
 8 lb  
 0 lb  
 \_\_\_\_\_  
 13573 lb

Structure Total:

Structure Notes:

1. PER ASTM C-478 SPECIFICATIONS
2. CONCRETE: 4,000 PSI AT 28 DAYS
3. REINFORCEMENT: #5 BAR @ 6" C.C. E.W. (GRADE 60) - 2" MIN. REBAR CLEARANCE (TYP)
4. HOE WT-420-MSD WATERTIGHT FRAME & COVER "STORM MSD" SUPPLIED BY ICAST
5. LIFTERS: 3 EA. WRA016 CONAC WIRE ROPE ANCHORS FOR PLANT & FIELD HANDLING
6. TOP SURFACE TO RECEIVE FLOATED FINISH

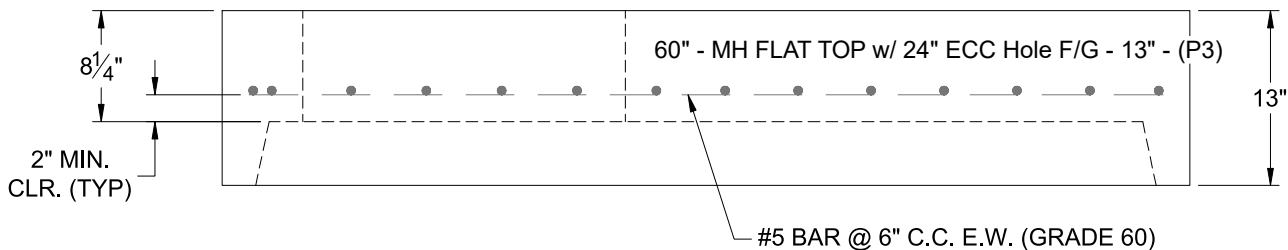
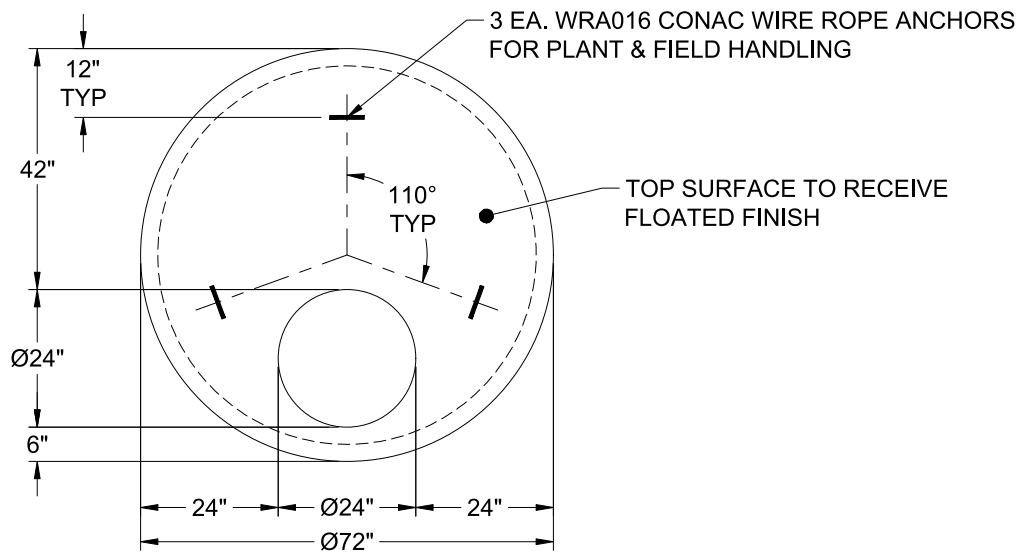

Coating (Int):  
 Coating (Ext):

Seam Up: Flat  
 Seam Dn: Groove

Wall Thickness: 6"

Height (Ext): 13"

Weight (Net): 2869 lb  
 Volume (Net): 0.73cu.yd

**Structure ID: TY 1 DHMH EAST SIDE**

**P1 MH060DHRSVH**

**MH DH RISER Custom Ht T/F**

P4) 24" - CASTING HEIGHT - 7" P3) 60" - MH FLAT TOP w/ 24" ECC Hole F/G - 13" P2) 60" - MH RISER T/G - 60" P1) 60" - MH DH RISER Custom Ht T/F - 51" 1) JOINT WRAP - 0.065"x6"x50" CONSEAL CS212 1) JOINT WRAP PRIMER - CONSEAL CS-75 (1 gal.) 1) CASTING - HOE WT-420-MSD F/C Storm 2) 60" - Conseal CS-102 1.00" (Double) 2) DOGHOUSE - 34"x35" 1) PSX - 16M NYLO 9) MH Step ML-10-TDS-NCR - 10"	0 lb 2869 lb 6264 lb 4092 lb 0 lb 0 lb 340 lb 0 lb 0 lb 8 lb 0 lb ----- Structure Total: 13573 lb
--	---

**Structure Notes:**

1. PER ASTM C-478 SPECIFICATIONS
2. CONCRETE: 4,000 PSI AT 28 DAYS
3. REINFORCEMENT: PER ASTM A615
4. STEPS AT 90 DEGREES
5. HOE WT-420-MSD WATERTIGHT FRAME & COVER "STORM MSD" SUPPLIED BY ICAST

Rim: 459.42'    Rim to Invert: 10.44'    Slack: 0.28"    Sump: 6"    Step Position: 90°

Position	Elev	Angle	Ext. (cw)	Pipe	Pipe OD	Connector	Hole	Horz Size	Up ( )	Offset
Invert 1	448.98'	0°	0"	24" RCP B WALL	30"	DOGHOUSE 34"x35"	34" x 35"	36.147"	0"	0"
Invert 2	448.98'	180°	113.125"	24" RCP B WALL	30"	DOGHOUSE 34"x35"	34" x 35"	36.147"	0"	0"
Invert 3	449.08'	270°	169.625"	12" PVC SDR35	12.5"	PSX 16M NYLO	16"	16.196"	5.25"	0"
Invert 4										
Invert 5										
Invert 6										
Invert 7										
Invert 8										

RIGHT-SIDE UP VIEW (int. dimensions)

UPSIDE-DOWN VIEW (int. dimenions)

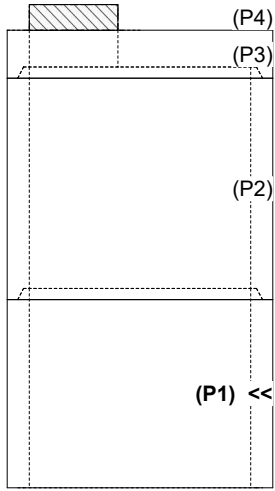
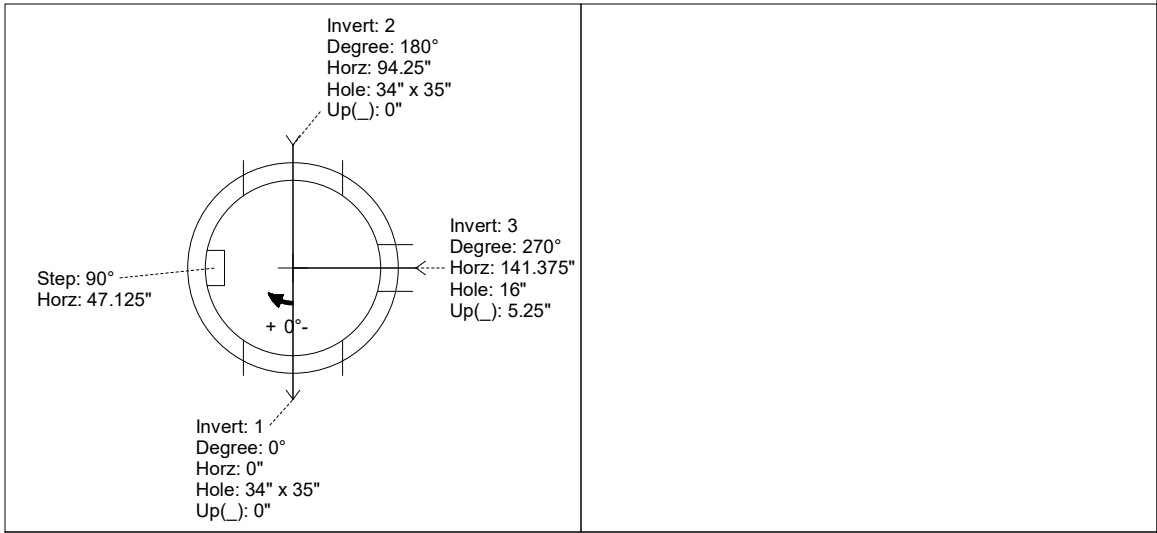

INSIDE WALL DIMENSIONS

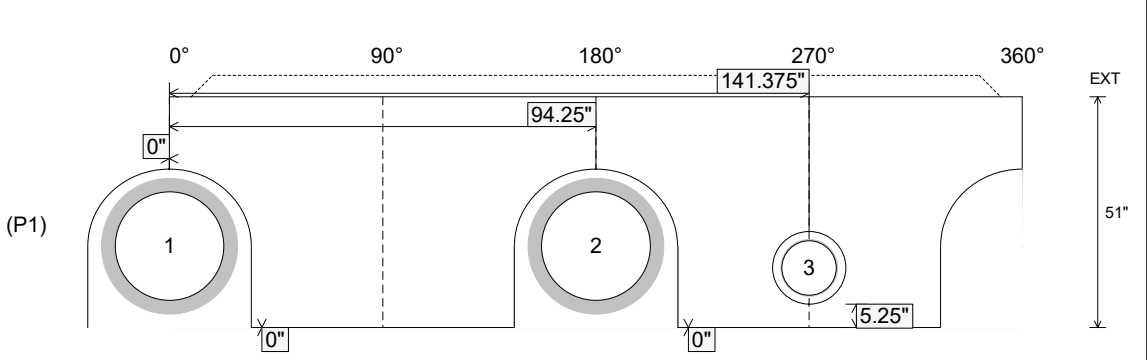

Coating (Int): Coating (Ext):	Seam Up: Tongue Seam Dn: Flat	Wall Thickness: 6" Floor Height: 0"	Height (Int): 51" Height (Ext): 51"	Weight (Net): 4092 lb Volume (Net): 1.04cu.yd
----------------------------------	----------------------------------	--	--	--

Job Name: 25-1431 - Georgetown Commons  
 Job Location: Georgetown, KY  
 Contractor: Winwater Hartford KY Co.

Plant: Beaver Dam

4/23/2026 11:20:10 AM

Tech: J. Coppage

PC: A. Chambers



**Structure ID: DCI 105**

**P1 MH060BA54**

**MH BASE**

- P3) 24" x 36" - CASTING HEIGHT - 6"
- P2) 60" - MH FLAT TOP w/24"x36" Hole - 8"
- P1) 60" - MH BASE - 54"
- 1) CASTING - HOE 470 SET (F/G/H)
- 1) 60" - Conseal CS-102 1.00"
- 1) 24" x 36" - Conseal CS-102 1.00"
- 2) Hole - 40
- 4) MH Step ML-10-TDS-NCR - 10"

Structure Notes:  
 1. JR HOE HOE-470 PROVIDED BY ICAST.  
 2. PER ASTM C478 SPECIFICATIONS.  
 3. CONCRETE = 4,000 PSI AT 28 DAYS.  
 4. REINFORCING PER ASTM A615 (GRADE 60).  
 - TOP SLAB (As .62) #5 BARS AT 6" C.C.E.W..  
 - RISER/WALLS (As .18)  
 - FLOOR (As .37) #5 BARS AT 10" C.C.E.W.

Structure Total: 9554 lb

Rim: 869.35' Rim to Invert: 5.6' Slack: 1.75" Sump: 2.55" Step Position: 90°

Position	Elev	Angle	Ext. (cw)	Pipe	Pipe OD	Connector	Hole	Horz Size	Up ( )	Offset
Invert 1	863.75'	0°	0"	30" HDPE	35.1"	Hole 40	40"	43.784"	0"	0"
Invert 2	863.75'	180°	113.097"	30" HDPE	35.1"	Hole 40	40"	43.784"	0"	0"
Invert 3										
Invert 4										
Invert 5										
Invert 6										
Invert 7										
Invert 8										

RIGHT-SIDE UP VIEW (int. dimensions)

UPSIDE-DOWN VIEW (int. dimensions)

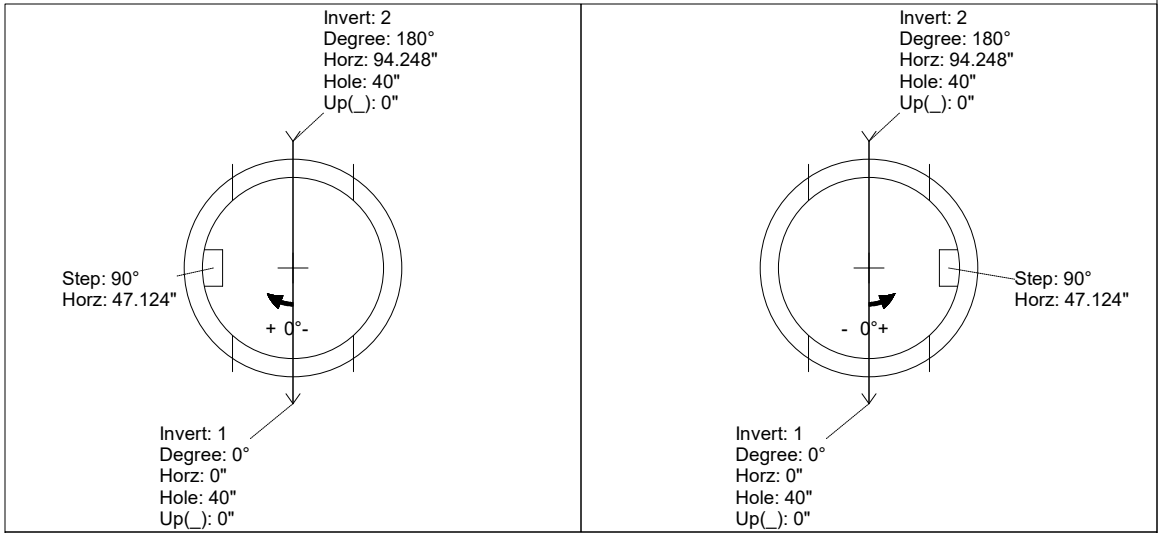
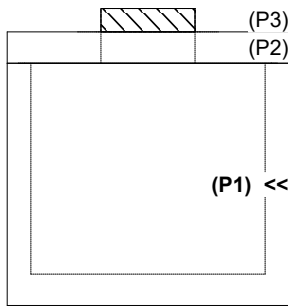

INSIDE WALL DIMENSIONS

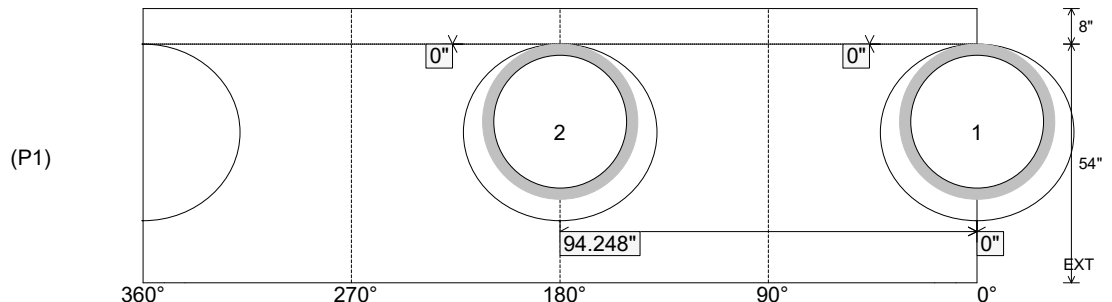

Coating (Int):  
 Coating (Ext):

Seam Up: Flat  
 Seam Dn: n/a

Wall Thickness: 6"  
 Floor Height: 8"

Height (Int): 54"  
 Height (Ext): 62"

Weight (Net): 7007 lb  
 Volume (Net): 1.79cu.yd

Job Name: 25-1431 - Georgetown Commons  
 Job Location: Georgetown, KY  
 Contractor: Winwater Hartford KY Co.

Plant: Beaver Dam

4/23/2026 11:30:47 AM

Tech: J. Coppage

PC: A. Chambers



**Structure ID: MH 114**

**P3 MH072LD15-24ECC**

**MH FLAT LID w/24in ECC Hole**

- P4) 24" - CASTING HEIGHT - 7"
- P3) 72" - MH FLAT LID w/24in ECC Hole - 15"
- P2) 72" - MH RISER Custom Ht - 20"
- P1) 72" - MH BASE - 84"
- 1) CASTING - HOE MC-420 F/C Storm LOU-MSD
- 2) 72" - Conseal CS-102 1.00"
- 2) Hole - 46
- 2) Hole - 30
- 7) MH Step ML-10-TDS-NCR - 10"

- Structure Notes:
1. JR HOE MC-420 PROVIDED BY ICAST.
  2. PER ASTM C478 SPECIFICATIONS.
  3. CONCRETE = 4,000 PSI AT 28 DAYS.
  4. REINFORCING PER ASTM A615 (GRADE 60).
    - TOP SLAB (As .62) #5 BARS AT 6" C.C.E.W..
    - RISER/WALLS (As .18)
    - FLOOR (As .37) #5 BARS AT 10" C.C.E.W.

Structure Total: 21557 lb

**GENERAL NOTES:**

1. MANUFACTURED TO ASTM C-478 (LATEST REVISION).
2. CONCRETE 4,000 PSI AT 28 DAYS.
3. REINFORCING: TOP MAT #4 @ 18" O.C. E.W. BOTTOM MAT #4 @ 9" O.C. E.W. (GRADE 60)

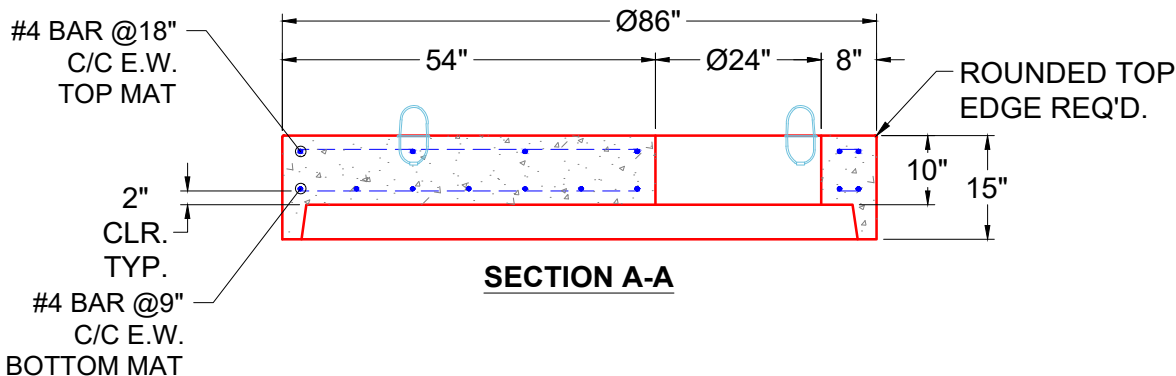
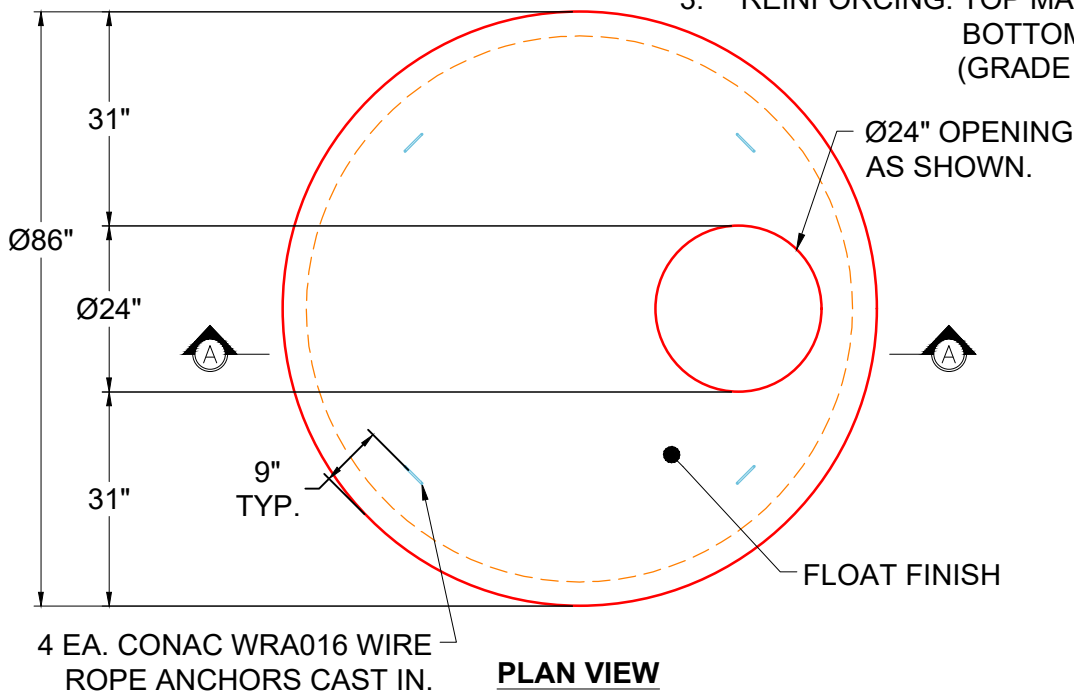

Coating (Int): Coating (Ext):	Seam Up: Flat Seam Dn: Groove	Wall Thickness: 7"	Height (Ext): 15"	Weight (Net): 5098 lb Volume (Net): 1.3cu.yd
----------------------------------	----------------------------------	--------------------	-------------------	---

Job Name: 25-3118 - W6 Ph 2-C Force Main Improvements  
 Job Location: Fort Mitchell, KY 41017  
 Contractor: Lykins Contracting

Plant: 100

Tech: J. Horsley - A

3/20/2026 1:21:15 PM

PC: Celina Goff



**Structure ID: 2301537**

**P1 MH072BAVF**

**MH BASE (10"F) Custom Ht T/n**

- P6) 24" - CASTING HEIGHT - 7"
- P5) 48" - CON CONE w/24" HOLE F/G - 24"
- P4) 48" - MH RISER T/G - 48"
- P3) 48" - MH RISER T/G - 60"
- P2) 72" - MH Transition Slab 48" Hole T/G - 15"
- P1) 72" - MH BASE (10"F) Custom Ht T/n - 76"
- 1) 72" - MH INVERT CHANNEL - FULL HEIGHT
- 1) 72" - Conseal CS-102 1.00" (Double)
- 3) 48" - Conseal CS-102 1.00" (Double)
- 2) A-Lok - 1235
- 1) PSX - 12-08 NYLO
- 18) MH Step ML-10-TDS-NCR - 10"

0 lb  
 2252 lb  
 3353 lb  
 4192 lb  
 3864 lb  
 14346 lb  
 5422 lb  
 0 lb  
 0 lb  
 2 lb  
 8 lb  
 0 lb  
 -----  
 Structure Total: 33439 lb

Structure Notes:

1. PER ASTM C-478 SPECIFICATIONS
2. CONCRETE: 4,000 PSI AT 28 DAYS
3. REINFORCEMENT:
  - WALLS: PER ASTM A615 - DOUBLE MAT
  - FLOOR: #5 BAR @ 12" C.C. E.W. (GRADE 60) - 2" MIN. REBAR CLEARANCE (TYP)
4. INVERT CHANNEL REQUIRED
5. STEPS AT 90 DEGREES
6. 7" CASTING SUPPLIED BY OTHERS

Rim: 750.63' Rim to Invert: 19.12' Slack: 2.44" Sump: 3" Step Position: 90°

Position	Elev	Angle	Ext. (cw)	Pipe	Pipe OD	Connector	Hole	Horz Size	Up (↓)	Offset
Invert 1	731.51'	0°	0"	36" PVC SDR35/F679	38.3"	A-Lok 1235	39.88"	42.266"	1.125"	0"
Invert 2	733.89'	180°	135.125"	8" PVC SDR35	8.5"	PSX 12-08 NYLO	12"	12.056"	29.5"	0"
Invert 3	731.61'	265°	198.875"	36" PVC SDR35/F679	38.3"	A-Lok 1235	39.88"	42.266"	2.25"	0"
Invert 4										
Invert 5										
Invert 6										
Invert 7										
Invert 8										

RIGHT-SIDE UP VIEW (int. dimensions)

UPSIDE-DOWN VIEW (int. dimensions)

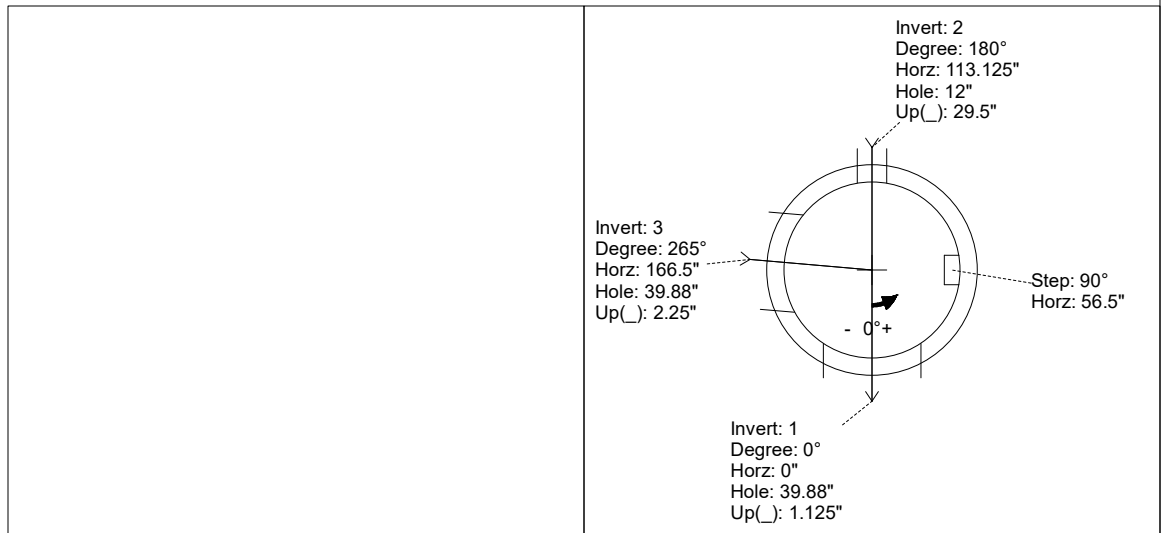
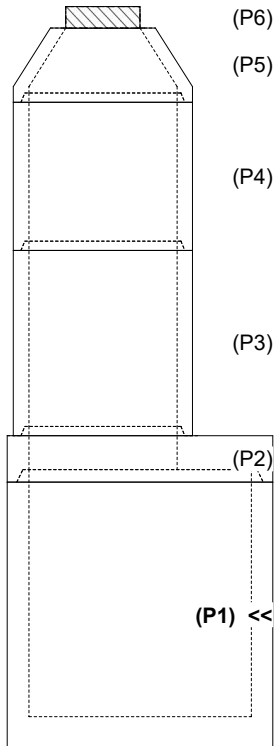

INSIDE WALL DIMENSIONS

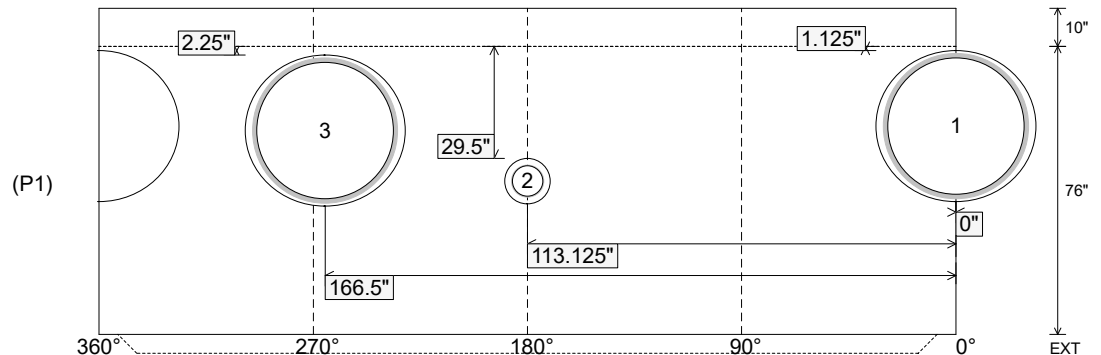

Coating (Int):  
 Coating (Ext):

Seam Up: Tongue  
 Seam Dn: n/a

Wall Thickness: 7"  
 Floor Height: 10"

Height (Int): 76"  
 Height (Ext): 86"

Weight (Net): 14346 lb  
 Volume (Net): 3.66cu.yd

**Structure ID: 2301537**

**P1 MH072BAVF**

**MH BASE (10" F) Custom Ht T/n**

P6) 24" - CASTING HEIGHT - 7" P5) 48" - CON CONE w/24" HOLE F/G - 24" P4) 48" - MH RISER T/G - 48" P3) 48" - MH RISER T/G - 60" P2) 72" - MH Transition Slab 48" Hole T/G - 15" P1) 72" - MH BASE (10" F) Custom Ht T/n - 76" 1) 72" - MH INVERT CHANNEL - FULL HEIGHT 1) 72" - Conseal CS-102 1.00" (Double) 3) 48" - Conseal CS-102 1.00" (Double) 2) A-Lok - 1235 1) PSX - 12-08 NYLO 18) MH Step ML-10-TDS-NCR - 10"	0 lb 2252 lb 3353 lb 4192 lb 3864 lb 14346 lb 5422 lb 0 lb 0 lb 2 lb 8 lb 0 lb ----- Structure Total: 33439 lb
---	---

**Structure Notes:**

1. PER ASTM C-478 SPECIFICATIONS
2. CONCRETE: 4,000 PSI AT 28 DAYS
3. REINFORCEMENT:
  - WALLS: PER ASTM A615 - DOUBLE MAT
  - FLOOR: #5 BAR @ 12" C.C. E.W. (GRADE 60) - 2" MIN. REBAR CLEARANCE (TYP)
4. INVERT CHANNEL REQUIRED
5. STEPS AT 90 DEGREES
6. 7" CASTING SUPPLIED BY OTHERS

Rim: 750.63'    Rim to Invert: 19.12'    Slack: 2.44"    Sump: 3"    Step Position: 90°

Position	Elev	Angle	Ext. (cw)	Pipe	Pipe OD	Connector	Hole	Horz Size	Up (↓)	Offset
Invert 1	731.51'	0°	0"	36" PVC SDR35/F679	38.3"	A-Lok 1235	39.88"	42.266"	1.125"	0"
Invert 2	733.89'	180°	135.125"	8" PVC SDR35	8.5"	PSX 12-08 NYLO	12"	12.056"	29.5"	0"
Invert 3	731.61'	265°	198.875"	36" PVC SDR35/F679	38.3"	A-Lok 1235	39.88"	42.266"	2.25"	0"
Invert 4										
Invert 5										
Invert 6										
Invert 7										
Invert 8										

**RIGHT-SIDE UP VIEW (int. dimensions)      UPSIDE-DOWN VIEW (int. dimenions)**

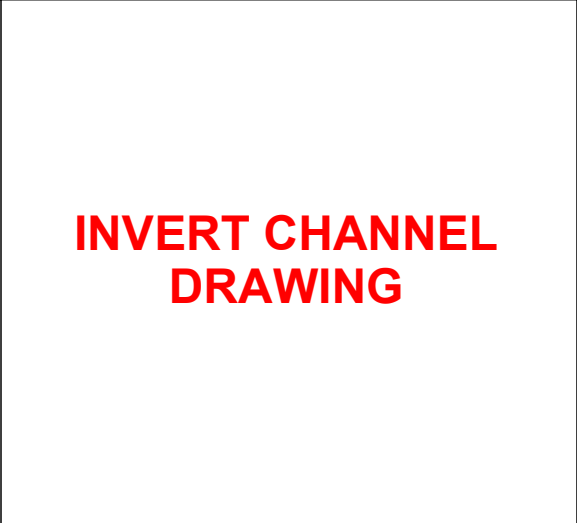
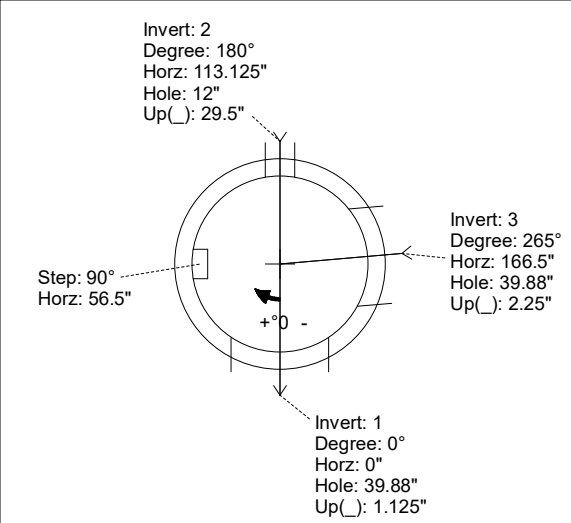
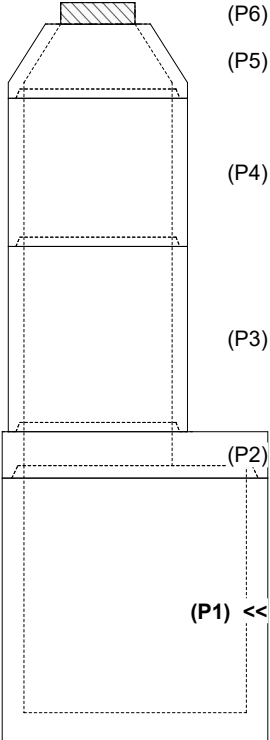

**INSIDE WALL DIMENSIONS**

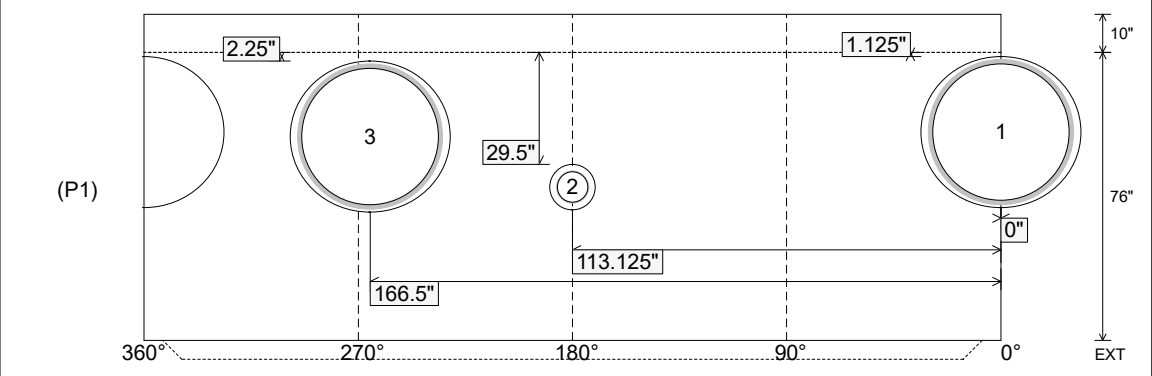

Coating (Int): Coating (Ext):	Seam Up: Tongue Seam Dn: n/a	Wall Thickness: 7" Floor Height: 10"	Height (Int): 76" Height (Ext): 86"	Weight (Net): 14346 lb Volume (Net): 3.66cu.yd
----------------------------------	---------------------------------	---	--	---

Job Name: 26-2087 839373 Georgetown Commons  
 Job Location: Georgetown, KY  
 Contractor: Contech Engineering Solutions

Plant: Beaver Dam  
 4/27/2026 2:30:08 PM

Tech: S. Felletter  
 PC: C. Goff



**Structure ID: 70-CS-8**

**P2 MH096RS96**

**MH RISER NO STEPS T/G**

- P5) 24" - CASTING HEIGHT - 4"
- P4) 96" - MH FLAT TOP SPEC. (2 - 24"Ø HOLES) F/G - 17"
- P3) 96" - MH RISER NO STEPS T/G - 60"
- P2) 96" - MH RISER NO STEPS T/G - 96"
- P1) 96" - MH MONOBASE 13F, Custom Ht T/n - 24"
- 1) CVSTENCILING
- 1) ASSEMBLY REQUIRED
- 3) 96" - Conseal CS-102 1.00"
- 2) Hole - 32

0 lb  
 10015 lb  
 14947 lb  
 22660 lb  
 17113 lb  
 0 lb  
 0 lb  
 0 lb  
 0 lb  
 -----  
 Structure Total: 64736 lb

**Structure Notes:**  
 4" CASTING BY OTHERS  
  
 LIFTING ANCHORS TO BE INSTALLED ON THE OUTSIDE OF THE STRUCTURE  
  
 ICAST TO INSTALL THE INTERNALS  
  
 CONTECH'S LOGO AS WELL AS THE INLET AND OUTLET MUST BE STENCILED ONTO THE STRUCTURE

Rim: 871.15' Rim to Invert: 10.05' Slack: 1.644" Sump: 82.044" Step Position:

Position	Elev	Angle	Ext. (cw)	Pipe	Pipe OD	Connector	Hole	Horz Size	Up ( )	Offset
Invert 1	861.1'	270°	268.606"	24" HDPE	27.8"	Hole 32	32"	32.624"	49.044"	0"
Invert 2	861.1'	210°	196.825"	24" HDPE	27.8"	Hole 32	32"	33.9"	49.044"	-12"
Invert 3										
Invert 4										
Invert 5										
Invert 6										
Invert 7										
Invert 8										

**RIGHT-SIDE UP VIEW (int. dimensions)**

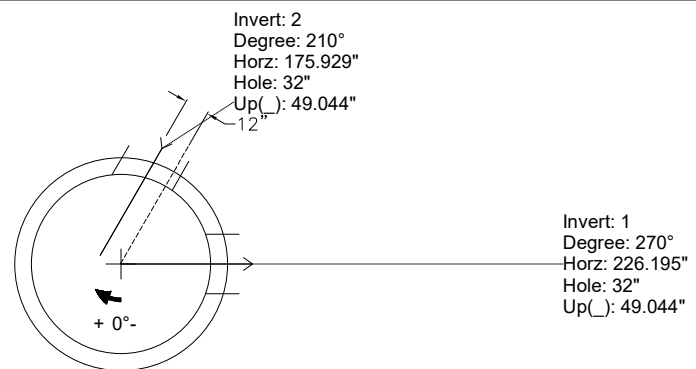
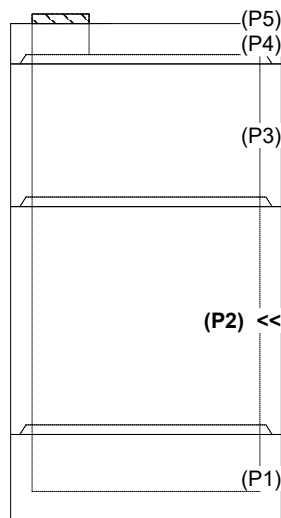

**INSIDE WALL DIMENSIONS**

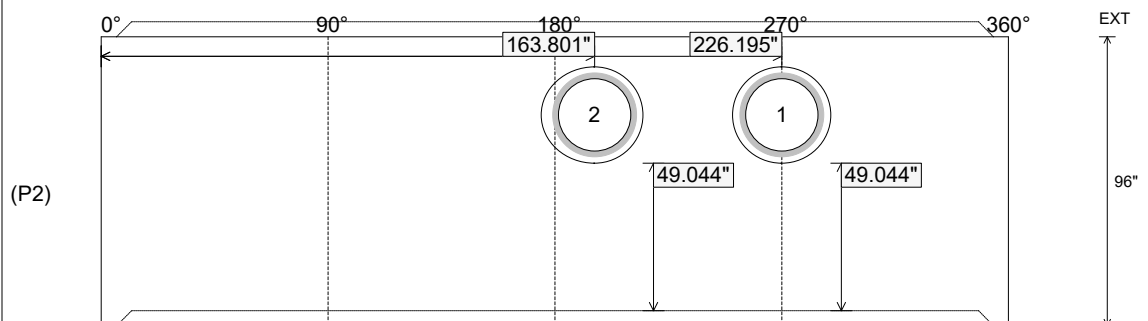

Coating (Int):  
 Coating (Ext):

Seam Up: Tongue  
 Seam Dn: Groove

Wall Thickness: 9"  
 Floor Height: 0"

Height (Int): 96"  
 Height (Ext): 96"

Weight (Net): 22660 lb  
 Volume (Net): 5.79cu.yd

Job Name: 26-2037 830068 Marketplace  
 Job Location: Georgetown, KY  
 Contractor: Contech Engineering Solutions

Plant: Beaver Dam  
 4/23/2026 11:53:37 AM

Tech: S. Felletter  
 PC: S. Goff



**Structure ID: 25-CS-8**

**P4 MH096LD17SP**

**MH FLAT TOP SPEC. (2 - 24"Ø HOLES) F/G**

- P5) 24" - CASTING HEIGHT - 4"
- P4) 96" - MH FLAT TOP SPEC. (2 - 24"Ø HOLES) F/G - 17"
- P3) 96" - MH RISER T/G - 36"
- P2) 96" - MH RISER T/G - 96"
- P1) 96" - MH MONOBASE 13F, Custom Ht T/n - 24"
- 1) CVSTENCILING
- 1) ASSEMBLY REQUIRED
- 3) 96" - Conseal CS-102 1.00"
- 2) Hole - 44

0 lb  
 10015 lb  
 8928 lb  
 21539 lb  
 17113 lb  
 0 lb  
 0 lb  
 0 lb  
 0 lb  
 -----  
 Structure Total: 57595 lb

Structure Notes:  
 4" CASTING BY OTHERS  
  
 LIFTING ANCHORS TO BE INSTALLED  
 ON THE OUTSIDE OF THE STRUCTURE  
  
 ICAST TO INSTALL THE INTERNALS  
  
 CONTECH'S LOGO AS WELL AS THE  
 INLET AND OUTLET MUST BE  
 STENCILED ONTO THE STRUCTURE

GENERAL NOTES:

1. MANUFACTURED TO ASTM C-478 (LATEST REVISION).
2. CONCRETE 5,000 PSI AT 28 DAYS.
3. WEIGHT: 10,015 LBS.
4. REINFORCING: TOP MAT: #4 BAR @ 18" C/C E.W.  
 BOTTOM MAT: #5 BAR @ 12" C/C E.W.  
 PER ASTM A615 (GRADE 60)

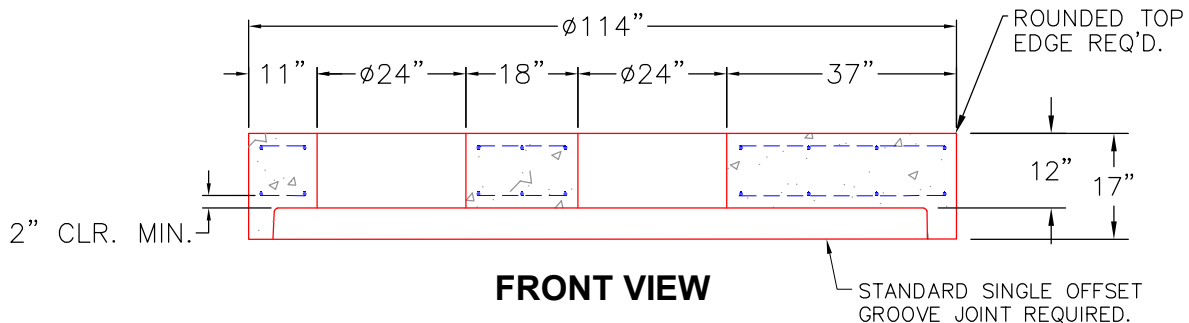
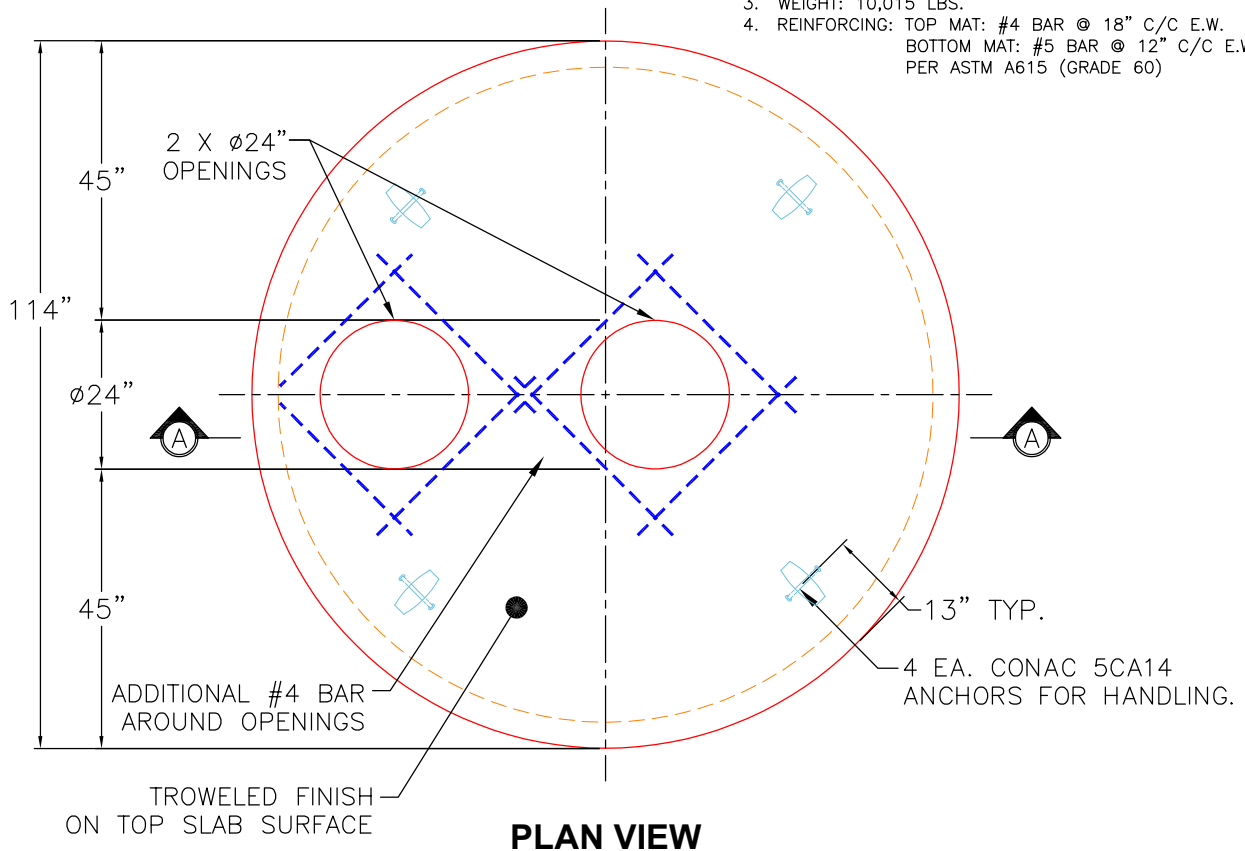

Coating (Int):  
 Coating (Ext):

Seam Up: Flat  
 Seam Dn: Groove

Wall Thickness: 9"

Height (Ext): 17"

Weight (Net): 10015 lb  
 Volume (Net): 2.56cu.yd

**Structure ID: BC 8 x 3 (PC 15)**  
**P1 BC096036-08WLF-9H**

**BOX CULVERT (08W/08F/08T) G/T**

- GENERAL NOTES:**
1. MANUFACTURED TO ASTM C-1577 & SECTION 714 OF INDOT STANDARD SPECIFICATIONS FOR REINFORCED CONCRETE BOX STRUCTURES
  2. LOAD REQUIREMENTS: HL93
  3. REINFORCEMENT PER ATTACHED DESIGN
  4. COVER DEPTH: 0'-5"
  5. CONCRETE: 5,000 PSI AT 28 DAYS
  6. JOINT SEALANT: 1" BUTYL MASTIC (CS-102)  
EXTERIOR JOINT WRAP: 12" WIDE (CS-212)
  7. WEIGHT: 8' X 3' RCBC = 2,548 LBS / LF  
(5'-9" LONG SECTION = 14,649 LBS)

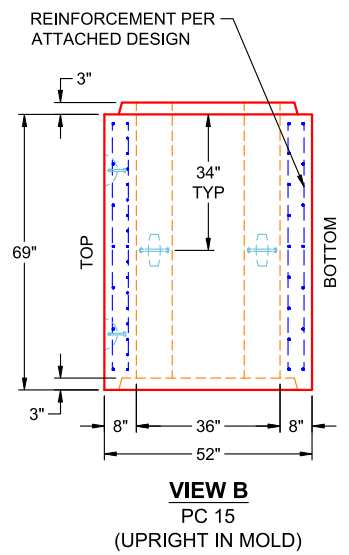
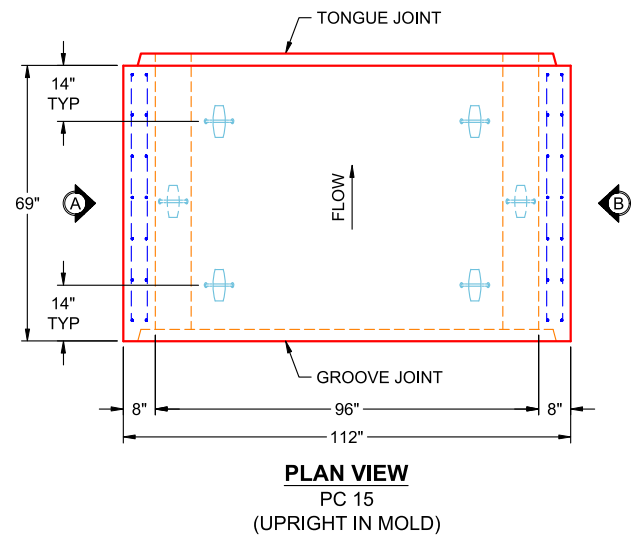
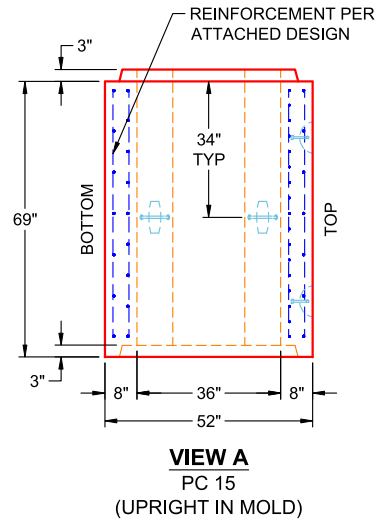
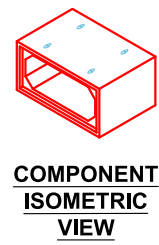
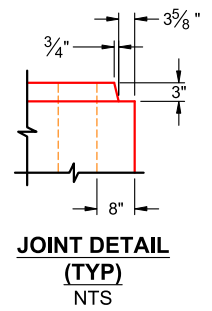
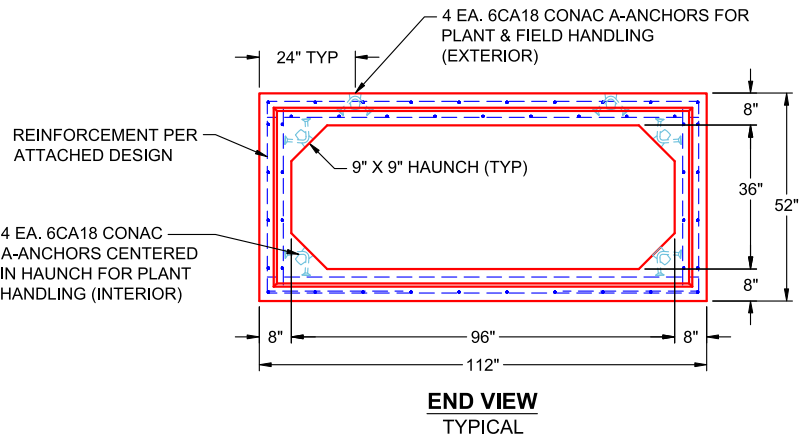

PRODUCTION WORK ORDER		PRODUCT I.D.: BC096036-08WLF-9H	DESCRIPTION: 96" X 36" X 69" BOX CULVERT (8" WALLS & 9" HAUNCH)
	QUALITY CONTROL CHECKLIST	PRODUCT VIEW: RIGHT SIDE UP	CUSTOMER: BOWEN ENGINEERING CORPORATION
	<input type="checkbox"/> ALL DIMENSIONS CORRECT.	PLANT: BEAVER DAM, KY	PROJECT: ALCOA OUTFALL
	<input type="checkbox"/> LIFTERS INSTALLED INSIDE.	WEIGHT: 14,649 LBS	STRUCTURE: BC 8 X 3 (PC 15)
	<input type="checkbox"/> RECESS WITH HAUNCHES CORRECT.	TOP SECTION JOINT: TONGUE	ORDER NO: 25-2073
	<input type="checkbox"/> REINFORCING CORRECT.	BASE SECTION JOINT: GROOVE	PE: J.H. ROSS
	<input type="checkbox"/> SURFACE QUALITY ACCEPTABLE.	QC CHECK INITIALS:	DRAWING: K. CARDWELL
	<input type="checkbox"/> LIFTERS INSTALLED OUTSIDE.		DATE: 04/17/26
<input type="checkbox"/> PRODUCT SQUARE.		SCALE: NTS	
			PG. 1 OF 1

THIS DRAWING IS THE PROPERTY OF INFRASTRUCTURE PRECAST, INC. ANY USE OR DUPLICATION OF THIS DRAWING WITHOUT PRIOR AUTHORIZATION IS STRICTLY PROHIBITED.



# INFRASTRUCTURE PRECAST (ICAST)

Sht \_\_\_\_\_ of \_\_\_\_\_  
 By: J. Horsley  
 Ck: \_\_\_\_\_  
 4/17/2026 8:47:34 AM  
 p. 1 of 4

Project : Alcoa Outfall  
 Task :  
 Job No. : 25-2073

Client: Bowen Engineering  
 File: 8x3 BC Four Sided - 25-2073 Alcoa Outfall.etcx

Spec.: LRFD 9th ed.  
 Type of Culvert: Precast

### Physical Dimensions

Clear Span: 8'-0"  
 Clear Height: 3'-0"  
 Top Slab: 8"  
 Bottom Slab: 8"  
 Ext. Wall: 8"  
 Fill Depth Range  
   Maximum: 5.00 ft  
   Minimum: 2.00 ft  
   Increment: 1.00 ft  
 Length: 5'-9"  
 Skew Angle: 0.00 deg  
 Bottom Slab Support: Full Slab  
 Top Haunch, Width: 9"  
 Top Haunch, Height: 9"  
 Bottom Haunch, Width: 9"  
 Bottom Haunch, Height: 9"

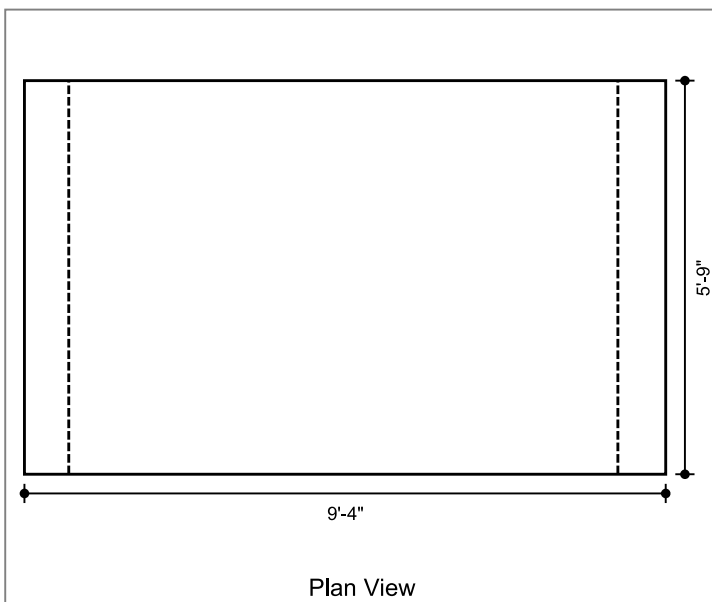

### Material Properties

**Concrete**  
 Strength, f<sub>c</sub>: 5.000 ksi  
 Density: 0.150 kcf  
 Elasticity, E<sub>c</sub>: 3834 ksi  
 Type: Normal wt

**Steel**  
 Yield, f<sub>y</sub>: 60 ksi  
 Allow Stress: 36 ksi  
 Elasticity, E<sub>s</sub>: 29000 ksi

**Soil**  
 Density: 0.120 kcf

**Exposure Factor**  
 Class 2 Exposure

**Reinforcement Covers**  
 Ext. Cover Top Slab: 2"  
 Ext. Cover Bottom Slab: 1"  
 Ext. Cover Walls: 1 1/2"  
 Int. Cover Walls: 1"  
 Int. Cover Top Slab: 1"  
 Int. Cover Bottom Slab: 1"

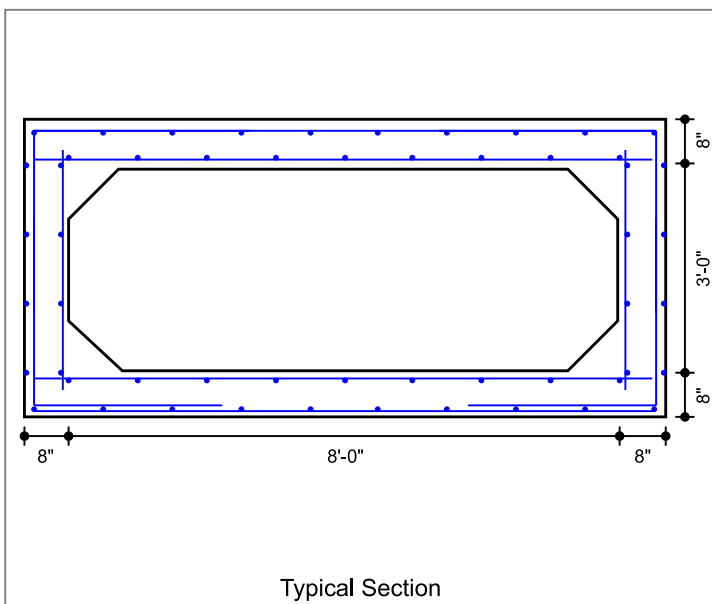

### Controlling Ratings

Inventory Rating: 1.14  
 Operating Rating: 1.48

### Loads

**Live Load**  
 Vehicle Names: HL-93  
 Traffic Direction: Parallel  
 Eq. Height of Soil: Calculated

**Dead Load**  
 Future Wearing Surface: 0.000 klf  
 Additional Dead Load: 0.000 klf  
 Concentrated Loads: none

**Lateral Soil Loads**  
 Eq. Fluid Press. Max: 60.00 pcf  
 Eq. Fluid Press. Min: 30.00 pcf

Interior Water Pressure: yes, head pressure = 0 ft  
 Exterior Water Pressure: no

# INFRASTRUCTURE PRECAST (ICAST)

Sht \_\_\_\_\_ of \_\_\_\_\_

By: J. Horsley

Ck: \_\_\_\_\_

4/17/2026 8:47:34 AM

p. 2 of 4

Project : Alcoa Outfall

Task :

Client: Bowen Engineering

Job No. : 25-2073

File: 8x3 BC Four Sided - 25-2073 Alcoa Outfall.etcx

## Concrete Summary

Volume of Concrete: 0.651 cy/ft Total Volume of Concrete: 3.742 cy

## Reinforcing Steel Bar Schedule (lb)

Location	Mark	Qty	Size	Spacing	Type	Length	Hor.Leg	Ver.Leg	Tot.Weight
Top Slab(Int)	A100 (AS2)	18	3	4"	S	9'-0"	--	--	61.0
Bot Slab(Int)	A200 (AS3)	9	4	8"	S	9'-0"	--	--	54.0
Top Slab(Ext)	A300 (AS7)	6	4	1'-0"	S	9'-0"	--	--	36.0
Bot Slab(Ext)	A400 (AS8)	6	4	1'-0"	S	9'-0"	--	--	36.0
Corner(Top)	A1 (AS1)	24	4	6"	L	5'-10"	3'-2"	2'-8"	94.0
Corner(Bot)	A2 (AS1)	24	4	6"	L	5'-6"	2'-9"	2'-9"	88.0
Wall(Int)	B1 (AS4)	12	4	1'-0"	S	3'-6"	--	--	28.0
Longit. Top (Int)	C100 (AS5)	9	4	1'-0"	S	5'-8"	--	--	34.0
Longit. Bot (Int)	C200	9	4	1'-0"	S	5'-8"	--	--	34.0
Longit. Top (Ext)	C1 (AS6)	10	4	1'-0"	S	5'-8"	--	--	37.9
Longit. Bot (Ext)	C1 (AS6)	10	4	1'-0"	S	5'-8"	--	--	37.9
Longit. Wall (Ext)	C1 (AS6)	8	4	1'-0"	S	5'-8"	--	--	30.4
Longit. Wall (Int)	C1 (AS6)	8	4	1'-0"	S	5'-8"	--	--	30.4
									602

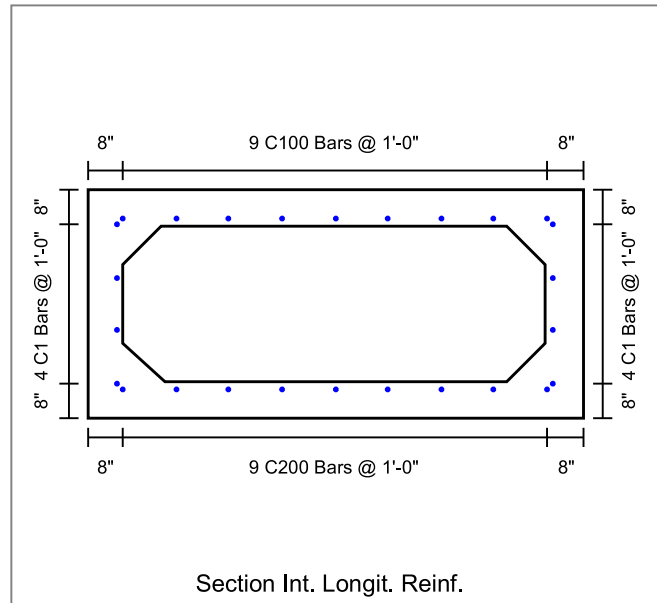
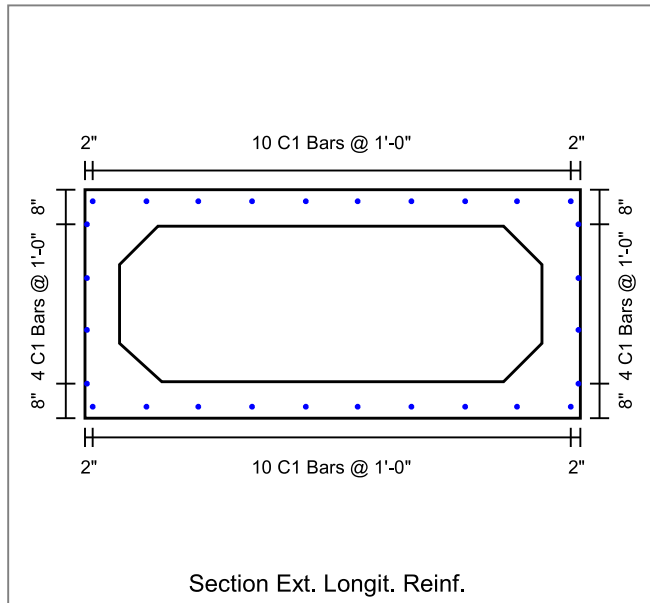

# INFRASTRUCTURE PRECAST (ICAST)

Sht \_\_\_\_\_ of \_\_\_\_\_

By: J. Horsley

Ck: \_\_\_\_\_

4/17/2026 8:47:34 AM

p. 3 of 4

Project : Alcoa Outfall

Task :

Job No. : 25-2073

Client: Bowen Engineering

File: 8x3 BC Four Sided - 25-2073 Alcoa Outfall.etcx



Ext. Wall Reinf.



Int. Wall Reinf.

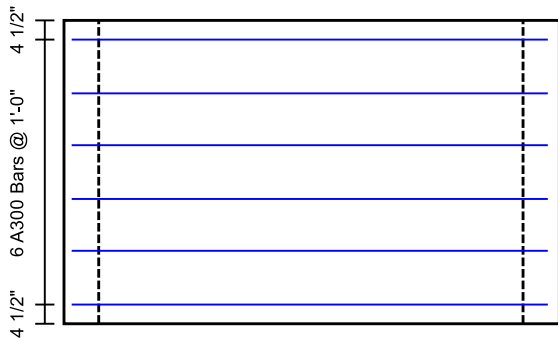

Top Slab Ext. Reinf.

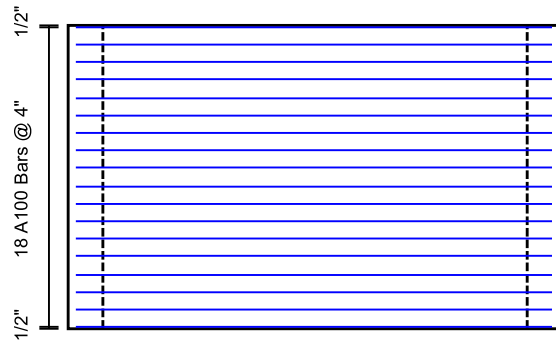

Top Slab Int. Reinf.

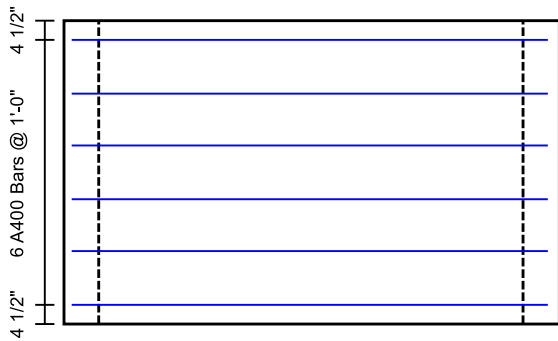

Bottom Slab Ext. Reinf.



Bottom Slab Int. Reinf.

# INFRASTRUCTURE PRECAST (ICAST)

Sht \_\_\_\_\_ of \_\_\_\_\_

By: J. Horsley

Ck: \_\_\_\_\_

4/17/2026 8:47:34 AM

p. 4 of 4

Project : Alcoa Outfall

Task :

Client: Bowen Engineering

Job No. : 25-2073

File: 8x3 BC Four Sided - 25-2073 Alcoa Outfall.etcx

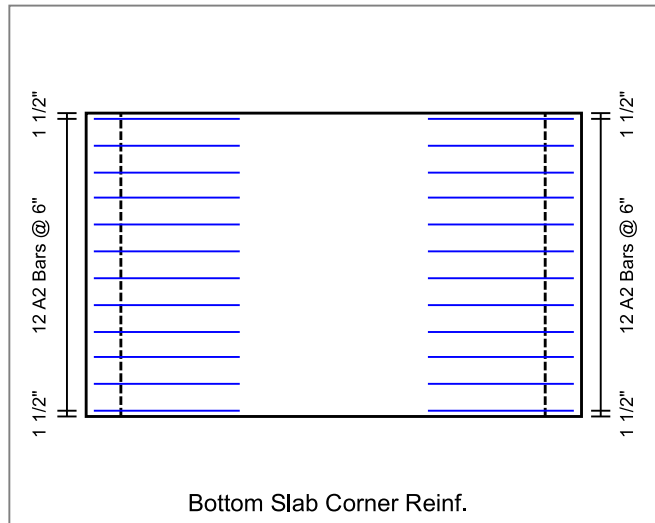
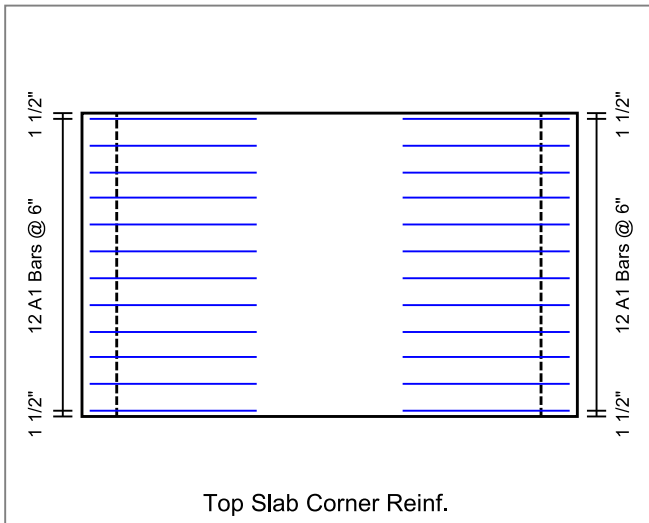

# ALCOA CONCRETE LOGS

Quantity 256

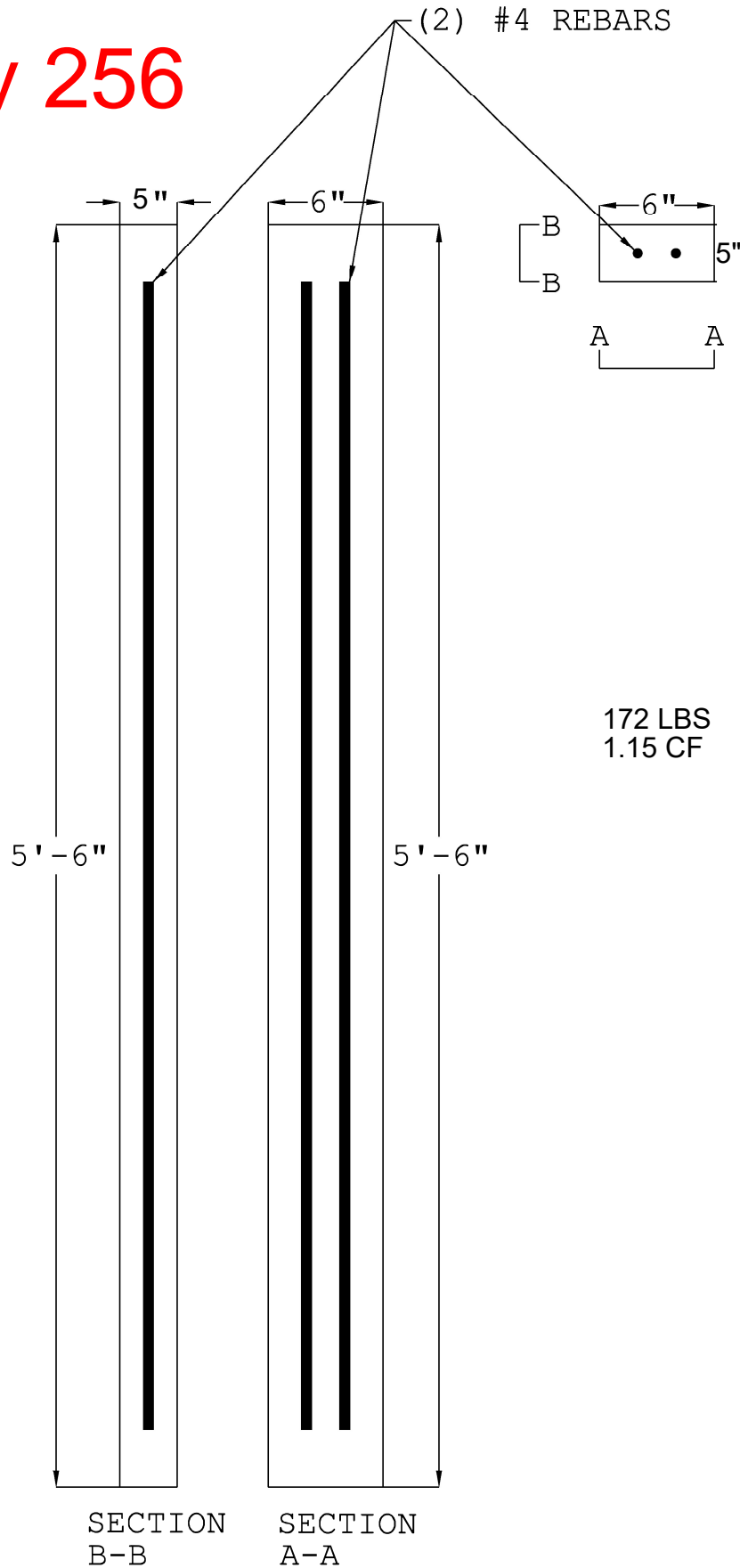

Job Name: 26-1077 - Westside Markets of Greensboro Village  
 Job Location: Gallatin, TN  
 Contractor: Cleary Construction, Inc.

Plant: 100  
 5/5/2026 12:10:50 PM

Tech: J. Coppage - F  
 PC: C. Goff



**Structure ID: B1**

**P1 BX2436-08BA48**

**BOX BASE 8inW, 8inF T/n**

- P3) 24" x 36" - CASTING HEIGHT - 5"
- P2) 24" x 36" - BOX RISER 8inW, Variable Ht F/G - 45"
- P1) 24" x 36" - BOX BASE 8inW, 8inF T/n - 48"
- 1) 24" x 36" - STORM INVERT CHANNEL (FLAT) - 4" THK
- 1) CASTING - EJ 6499 Beehive Grate
- 2) 24" x 36" - Conseal CS-102 1.00"
- 2) Hole - 38
- 2) Hole - 6

0 lb  
 4592 lb  
 5114 lb  
 450 lb  
 250 lb  
 0 lb  
 0 lb  
 0 lb  
 -----  
 Structure Total: 10406 lb

**Structure Notes:**  
 1. PER ASTM C913 SPECIFICATIONS.  
 2. CONCRETE = 4,000 PSI AT 28 DAYS.  
 3. NO STEPS.  
 4. CASTING SUPPLIED BY I-CAST (EJ 6499).  
 REINFORCING PER ASTM A615 (GRADE 60).  
 - WALLS (As .12) #5 BARS AT 12" C.C.E.W.  
 - FLOOR (As .12) #5 BARS AT 12" C.C.E.W.

Rim: 497' Rim to Invert: 8.2' Slack: 0.4" Sump: 0" Step Position:

Position	Elev	Angle	Ext. (cw)	Pipe	Pipe OD	Connector	Hole	Horz Size	Up ( )	Offset
Invert 1	488.8'	270°	26"	30" HDPE	35.1"	Hole 38	38"	37"	-2.5"	0"
Invert 2	488.9'	90°	26"	30" HDPE	35.1"	Hole 38	38"	37"	-1.375"	0"
Invert 3	490.96'	0°	20"	4" HDPE (perf pipe)	4.8"	Hole 6	6"	6"	25.5"	0"
Invert 4	490.96'	180°	20"	4" HDPE (perf pipe)	4.8"	Hole 6	6"	6"	25.5"	0"
Invert 5										
Invert 6										
Invert 7										
Invert 8										

RIGHT-SIDE UP VIEW (int. dimensions)

UPSIDE-DOWN VIEW (int. dimensions)

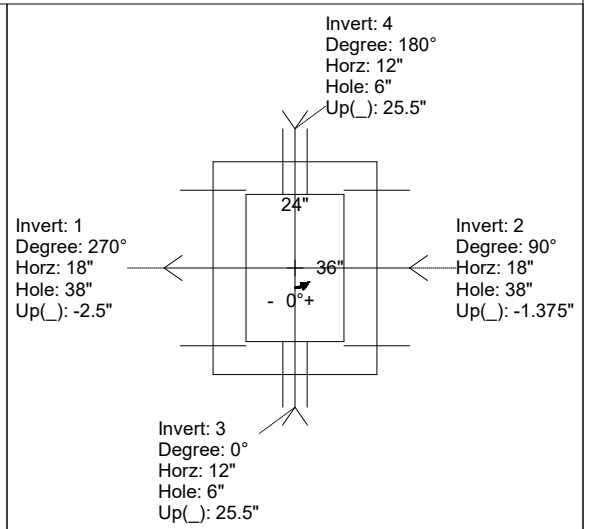
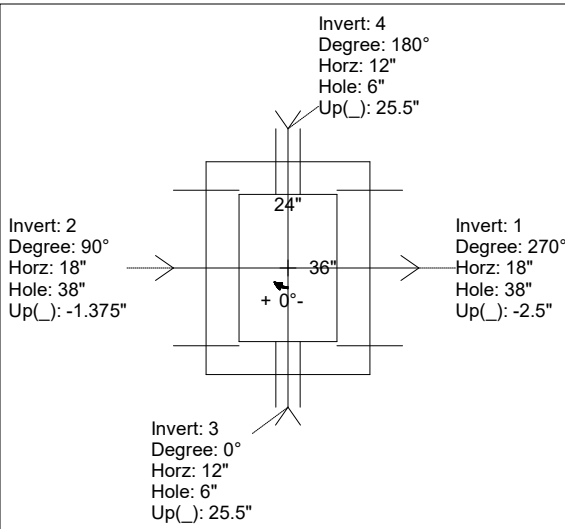
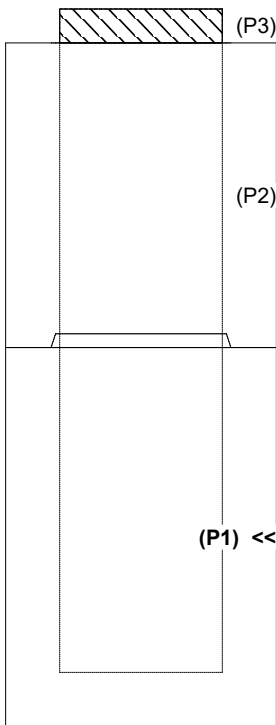

INSIDE WALL DIMENSIONS

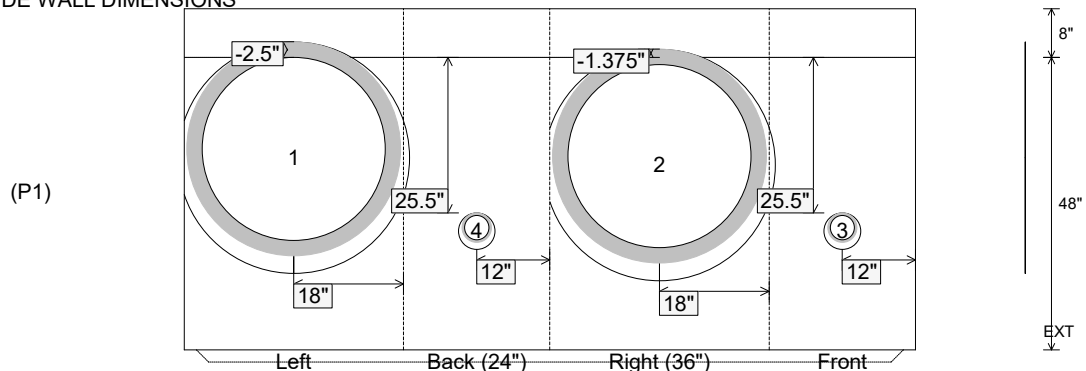

Coating (Int):  
 Coating (Ext):

Seam Up: Tongue  
 Seam Dn: n/a

Wall Thickness: 8"  
 Floor Height: 8"

Height (Int): 48"  
 Height (Ext): 56"

Weight (Net): 5114 lb  
 Volume (Net): 1.31cu.yd

Job Name: 26-1077 - Westside Markets of Greensboro Village  
 Job Location: Gallatin, TN  
 Contractor: Cleary Construction, Inc.

Plant: 100  
 5/5/2026 12:10:50 PM

Tech: J. Coppage - F  
 PC: C. Goff



**Structure ID: B1**

**P1 BX2436-08BA48**

**BOX BASE 8inW, 8inF T/n**

- P3) 24" x 36" - CASTING HEIGHT - 5"
- P2) 24" x 36" - BOX RISER 8inW, Variable Ht F/G - 45"
- P1) 24" x 36" - BOX BASE 8inW, 8inF T/n - 48"

1) 24" x 36" - STORM INVERT CHANNEL (FLAT) - 4" THK

- 1) CASTING - EJ 6499 Beehive Grate
- 2) 24" x 36" - Conseal CS-102 1.00"
- 2) Hole - 38
- 2) Hole - 6

0 lb  
 4592 lb  
 5114 lb  
 450 lb  
 250 lb  
 0 lb  
 0 lb  
 0 lb  
 -----  
 Structure Total: 10406 lb

**Structure Notes:**

1. PER ASTM C913 SPECIFICATIONS.
2. CONCRETE = 4,000 PSI AT 28 DAYS.
3. NO STEPS.
4. CASTING SUPPLIED BY I-CAST (EJ 6499).

REINFORCING PER ASTM A615 (GRADE 60).  
 - WALLS (As .12) #5 BARS AT 12" C.C.E.W.  
 - FLOOR (As .12) #5 BARS AT 12" C.C.E.W.

Rim: 497' Rim to Invert: 8.2' Slack: 0.4" Sump: 0" Step Position:

Position	Elev	Angle	Ext. (cw)	Pipe	Pipe OD	Connector	Hole	Horz Size	Up ( )	Offset
Invert 1	488.8'	270°	26"	30" HDPE	35.1"	Hole 38	38"	37"	-2.5"	0"
Invert 2	488.9'	90°	26"	30" HDPE	35.1"	Hole 38	38"	37"	-1.375"	0"
Invert 3	490.96'	0°	20"	4" HDPE (perf pipe)	4.8"	Hole 6	6"	6"	25.5"	0"
Invert 4	490.96'	180°	20"	4" HDPE (perf pipe)	4.8"	Hole 6	6"	6"	25.5"	0"
Invert 5										
Invert 6										
Invert 7										
Invert 8										

RIGHT-SIDE UP VIEW (int. dimensions)

UPSIDE-DOWN VIEW (int. dimensions)

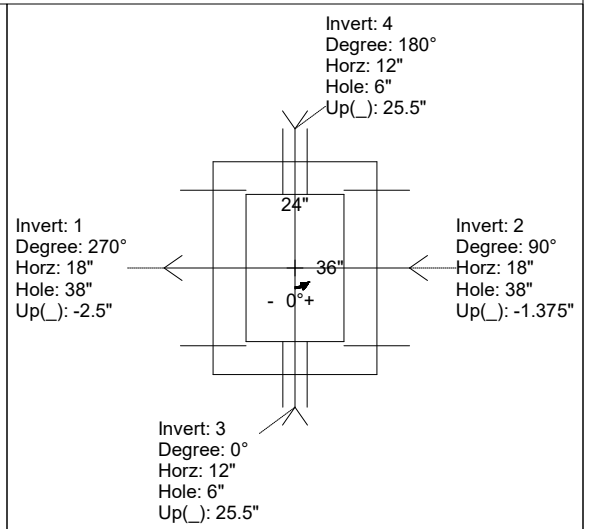
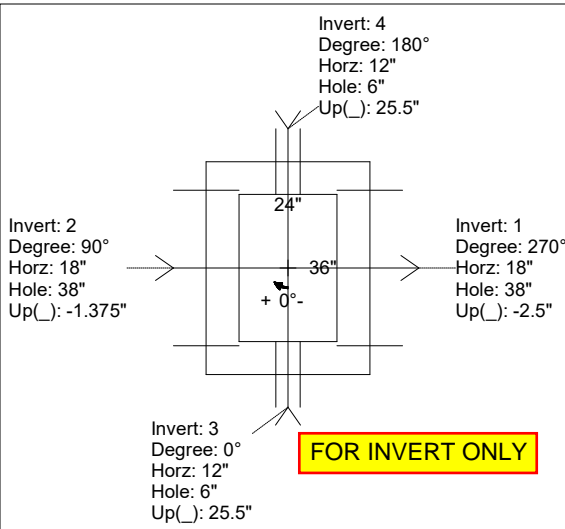
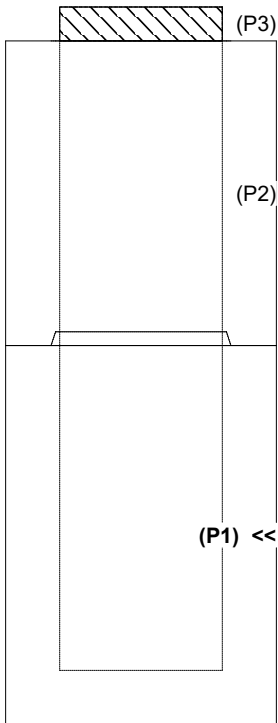

INSIDE WALL DIMENSIONS

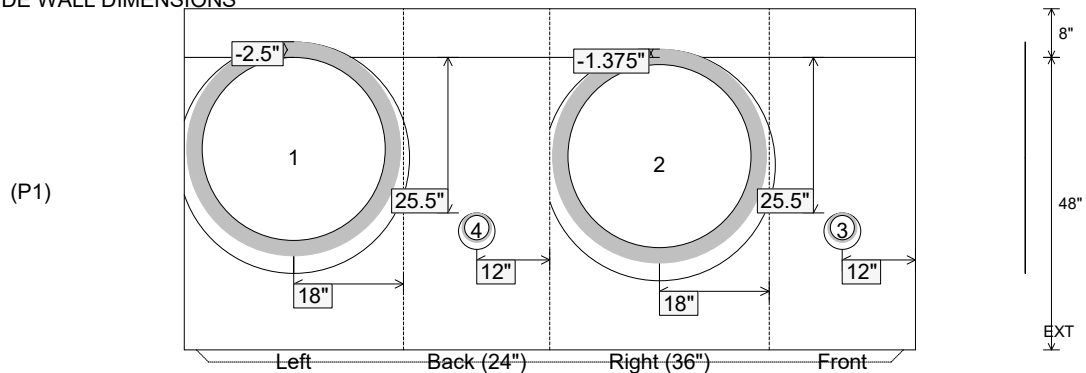

Coating (Int):  
 Coating (Ext):

Seam Up: Tongue  
 Seam Dn: n/a

Wall Thickness: 8"  
 Floor Height: 8"

Height (Int): 48"  
 Height (Ext): 56"

Weight (Net): 5114 lb  
 Volume (Net): 1.31cu.yd

Job Name: 26-1077 - Westside Markets of Greensboro Village  
 Job Location: Gallatin, TN  
 Contractor: Cleary Construction, Inc.

Plant: 100  
 5/5/2026 12:11:08 PM

Tech: J. Coppage - F  
 PC: C. Goff



**Structure ID: B1**

**P2 BX2436-08R-VH**

**BOX RISER 8inW, Variable Ht F/G**

- P3) 24" x 36" - CASTING HEIGHT - 5"
- P2) 24" x 36" - BOX RISER 8inW, Variable Ht F/G - 45"
- P1) 24" x 36" - BOX BASE 8inW, 8inF T/n - 48"
- 1) 24" x 36" - STORM INVERT CHANNEL (FLAT) - 4" THK
- 1) CASTING - EJ 6499 Beehive Grate
- 2) 24" x 36" - Conseal CS-102 1.00"
- 2) Hole - 38
- 2) Hole - 6

0 lb  
 4592 lb  
 5114 lb  
 450 lb  
 250 lb  
 0 lb  
 0 lb  
 0 lb  
 -----  
 Structure Total: 10406 lb

Structure Notes:  
 1. PER ASTM C913 SPECIFICATIONS.  
 2. CONCRETE = 4,000 PSI AT 28 DAYS.  
 3. NO STEPS.  
 4. CASTING SUPPLIED BY I-CAST (EJ 6499).  
 REINFORCING PER ASTM A615 (GRADE 60).  
 - WALLS (As .12) #5 BARS AT 12" C.C.E.W.  
 - FLOOR (As .12) #5 BARS AT 12" C.C.E.W.

Rim: 497' Rim to Invert: 8.2' Slack: 0.4" Sump: 0" Step Position:

Position	Elev	Angle	Ext. (cw)	Pipe	Pipe OD	Connector	Hole	Horz Size	Up (L)	Offset
Invert 1										
Invert 2										
Invert 3										
Invert 4										
Invert 5										
Invert 6										
Invert 7										
Invert 8										

**RIGHT-SIDE UP VIEW (int. dimensions)**

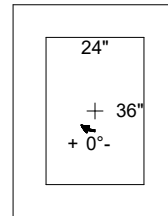
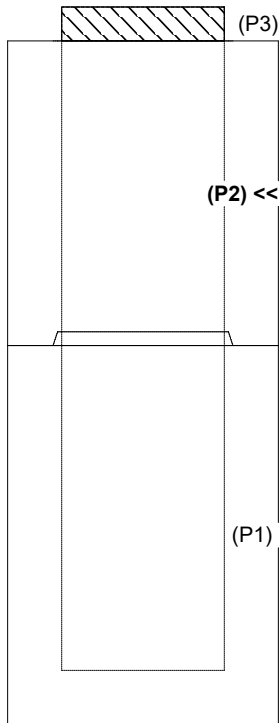

**INSIDE WALL DIMENSIONS**

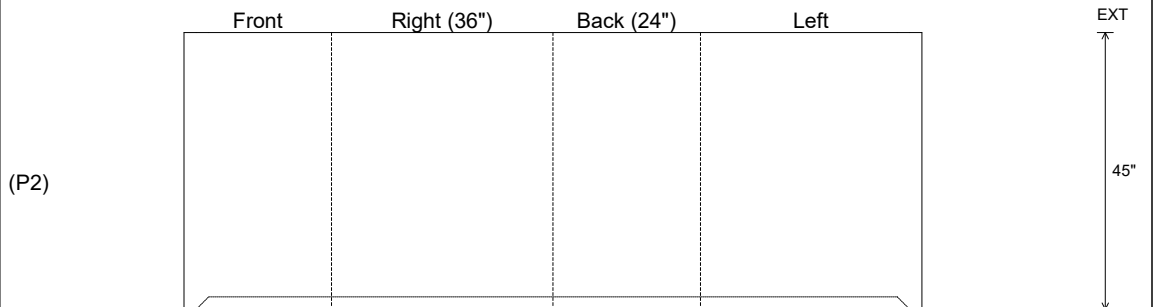

Coating (Int): Coating (Ext):	Seam Up: Flat Seam Dn: Groove	Wall Thickness: 8" Floor Height: 0"	Height (Int): 45" Height (Ext): 45"	Weight (Net): 4592 lb Volume (Net): 1.17cu.yd
----------------------------------	----------------------------------	--	--	--

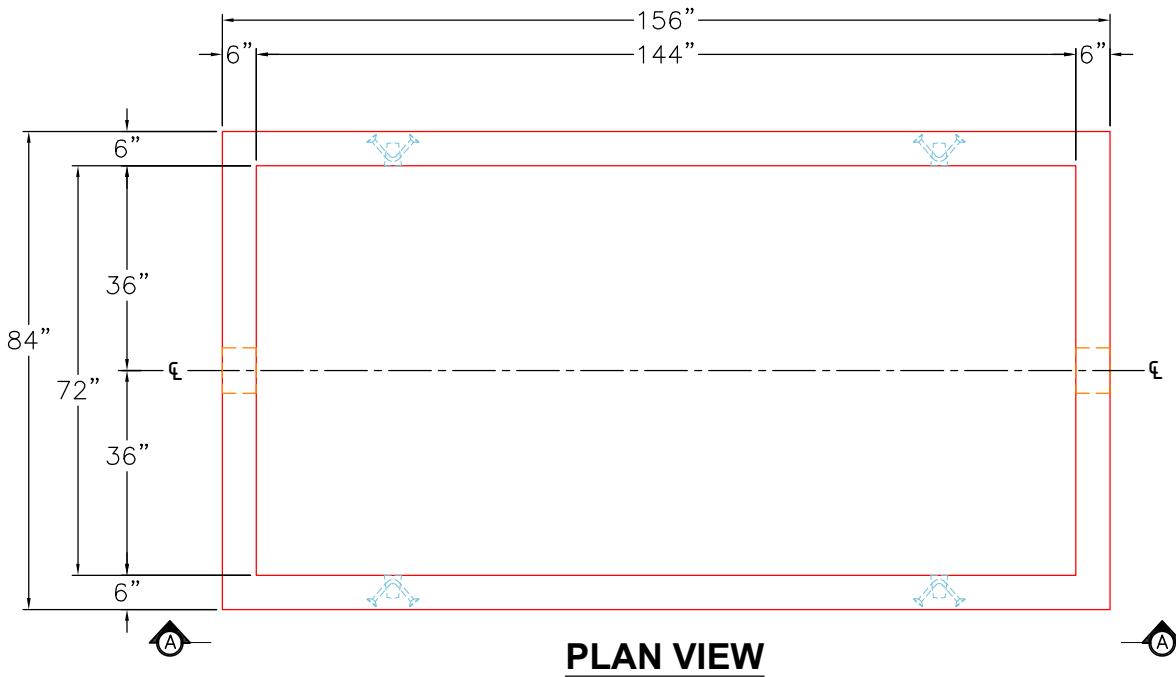

**PLAN VIEW**

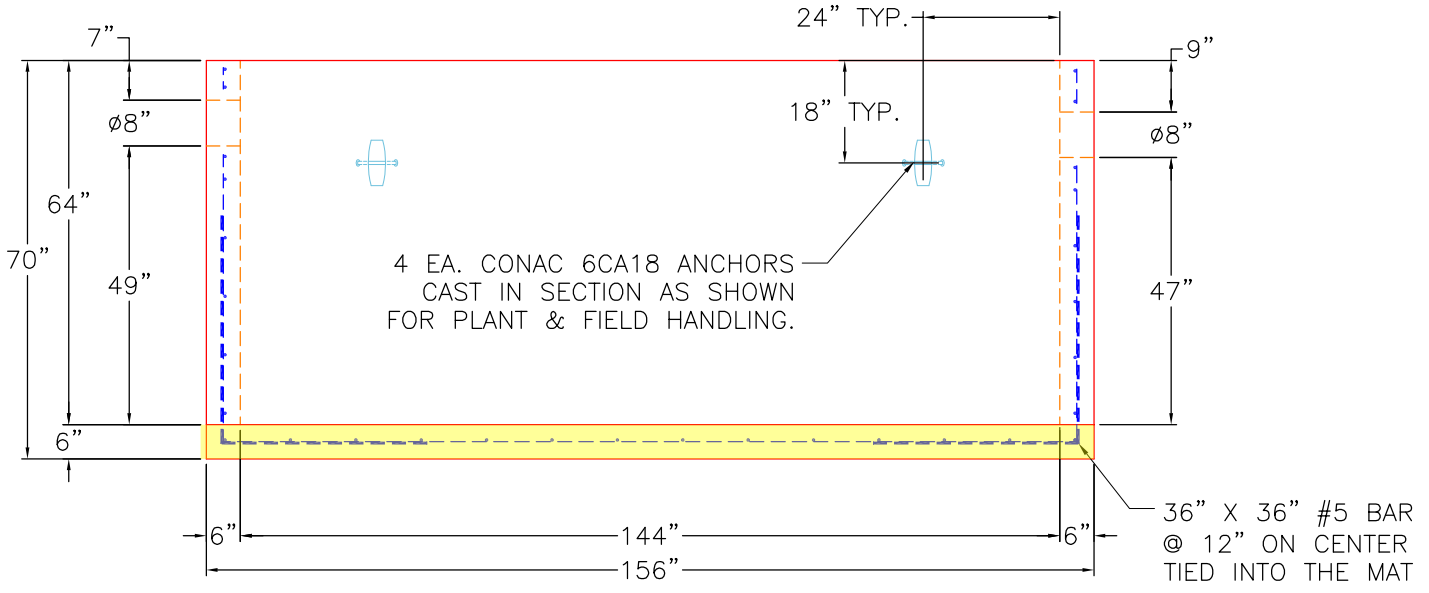

**SECTION A-A**

**GENERAL NOTES:**

1. MANUFACTURED TO ASTM C-913 (LATEST REVISION).
2. CONCRETE: 4,500 PSI AT 28 DAYS. CONCRETE.
3. REINFORCING: WALLS AND FLOOR #5 BAR @ 12" E.W. O.C. (GRADE 60).
4. WEIGHTS: TOTAL = 23,431 LBS  
 FIRST POUR = 6,598 LBS  
 SECOND POUR = 14,643 LBS  
 THIRD POUR = 2,190 LBS
5. ICAST TO PROVIDE 2X PSX 8QRS DD BOOTS
6. JOINT SEALANT TO BE CONSEAL CS-102, 1".

**FIRST POUR DRAWING**

<b>PRODUCTION WORK ORDER</b>		PRODUCT I.D.: BX072144-06W06F-VFFT	DESCRIPTION: 72" X 144" X 64" TALL 2,000 GAL GREASE TRAP BASE	
	<b>QUALITY CONTROL CHECKLIST</b>	PRODUCT VIEW: RIGHT SIDE UP	CUSTOMER: CORE & MAIN LP	
	<input type="checkbox"/> ALL DIMENSIONS CORRECT.	PLANT: BEAVER DAM, KY.	PROJECT: METRO CENTER GREASE TRAP	
	<input type="checkbox"/> LIFTERS INSTALLED.	WEIGHT: 23,431 LBS.	STRUCTURE: QL1 GT2000 (1)	
	<input type="checkbox"/> HOLE LOCATION(S) CORRECT.	TOP SECTION JOINT: N/A	ORDER NO: 26-2242	
	<input type="checkbox"/> REINFORCING CORRECT.	BASE SECTION JOINT: N/A	PC: T. RYAN	DRAWING: S. FELLETTER
	<input type="checkbox"/> BAFFLE POURED CORRECTLY. <input type="checkbox"/> BOOTS & BANDS INSTALLED. <input type="checkbox"/> SURFACE QUALITY ACCEPTABLE.	QC CHECK INITIALS:	DATE: 05/07/26	SCALE: NTS   PG. 1 of 1

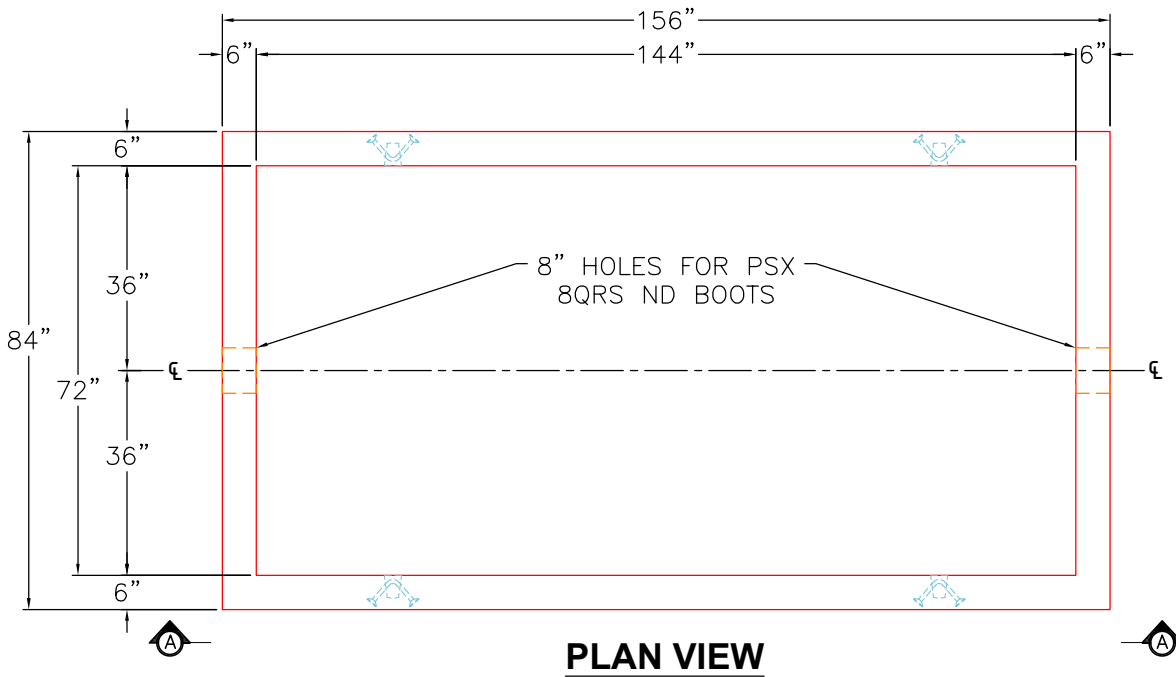

**PLAN VIEW**

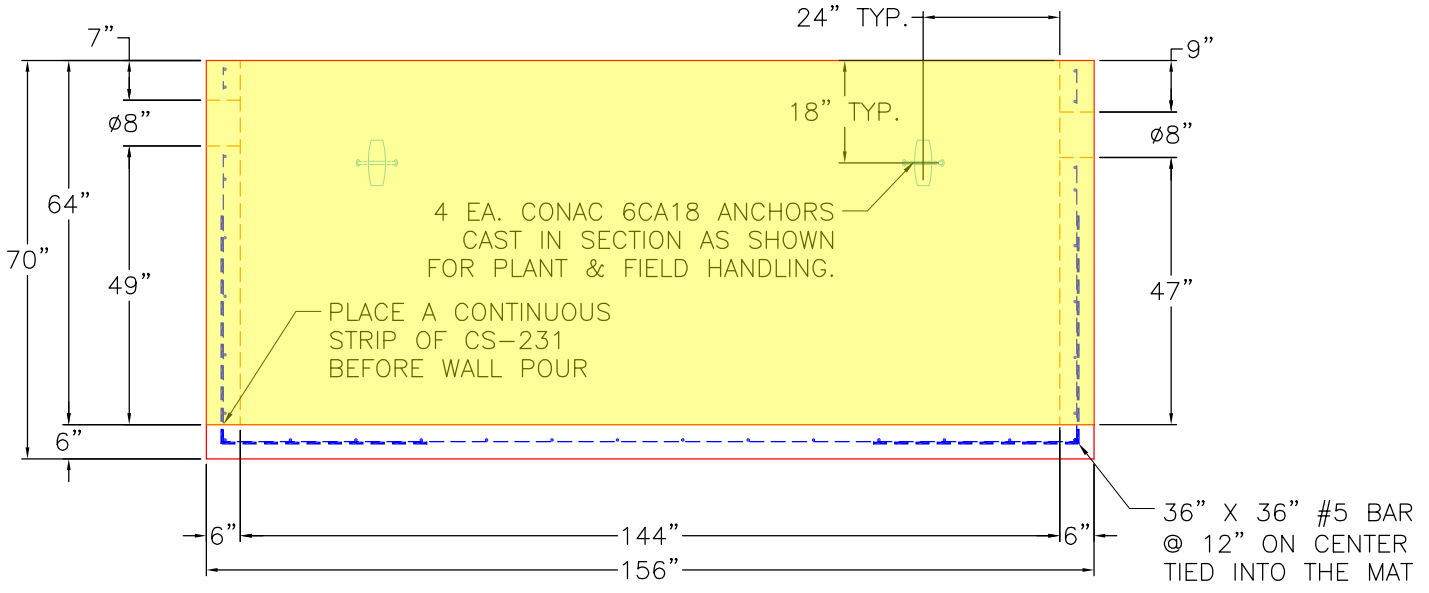

**SECTION A-A**

**GENERAL NOTES:**

1. MANUFACTURED TO ASTM C-913 (LATEST REVISION).
2. CONCRETE: 4,500 PSI AT 28 DAYS. CONCRETE.
3. REINFORCING: WALLS AND FLOOR #5 BAR @ 12" E.W. O.C. (GRADE 60).
4. WEIGHTS: TOTAL = 23,431 LBS  
FIRST POUR = 6,598 LBS  
SECOND POUR = 14,643 LBS  
THIRD POUR = 2,190 LBS
5. ICAST TO PROVIDE 2X PSX 8QRS DD BOOTS
6. JOINT SEALANT TO BE CONSEAL CS-102, 1".

**SECOND POUR DRAWING**

<p>PRODUCTION WORK ORDER</p>		<p>PRODUCT I.D.: BX072144-06W06F-VFFT</p>	<p>DESCRIPTION: 72" X 144" X 64" TALL 2,000 GAL GREASE TRAP BASE</p>	
	<p>QUALITY CONTROL CHECKLIST</p>	<p>PRODUCT VIEW: RIGHT SIDE UP</p>	<p>CUSTOMER: CORE &amp; MAIN LP</p>	
	<p><input type="checkbox"/> ALL DIMENSIONS CORRECT.</p>	<p>PLANT: BEAVER DAM, KY.</p>	<p>PROJECT: METRO CENTER GREASE TRAP</p>	
	<p><input type="checkbox"/> LIFTERS INSTALLED.</p>	<p>WEIGHT: 23,431 LBS.</p>	<p>STRUCTURE: QL1 GT2000 (1)</p>	
	<p><input type="checkbox"/> HOLE LOCATION(S) CORRECT.</p>	<p>TOP SECTION JOINT: N/A</p>	<p>ORDER NO: 26-2242</p>	
	<p><input type="checkbox"/> REINFORCING CORRECT.</p>	<p>BASE SECTION JOINT: N/A</p>	<p>PC: T. RYAN</p>	<p>DRAWING: S. FELLETTER</p>
	<p><input type="checkbox"/> BAFFLE POURED CORRECTLY.</p>	<p>QC CHECK INITIALS:</p>	<p>DATE: 05/07/26</p>	<p>SCALE: NTS</p>
<p><input type="checkbox"/> BOOTS &amp; BANDS INSTALLED.</p>			<p>PG. 1 of 1</p>	
<p><input type="checkbox"/> SURFACE QUALITY ACCEPTABLE.</p>				

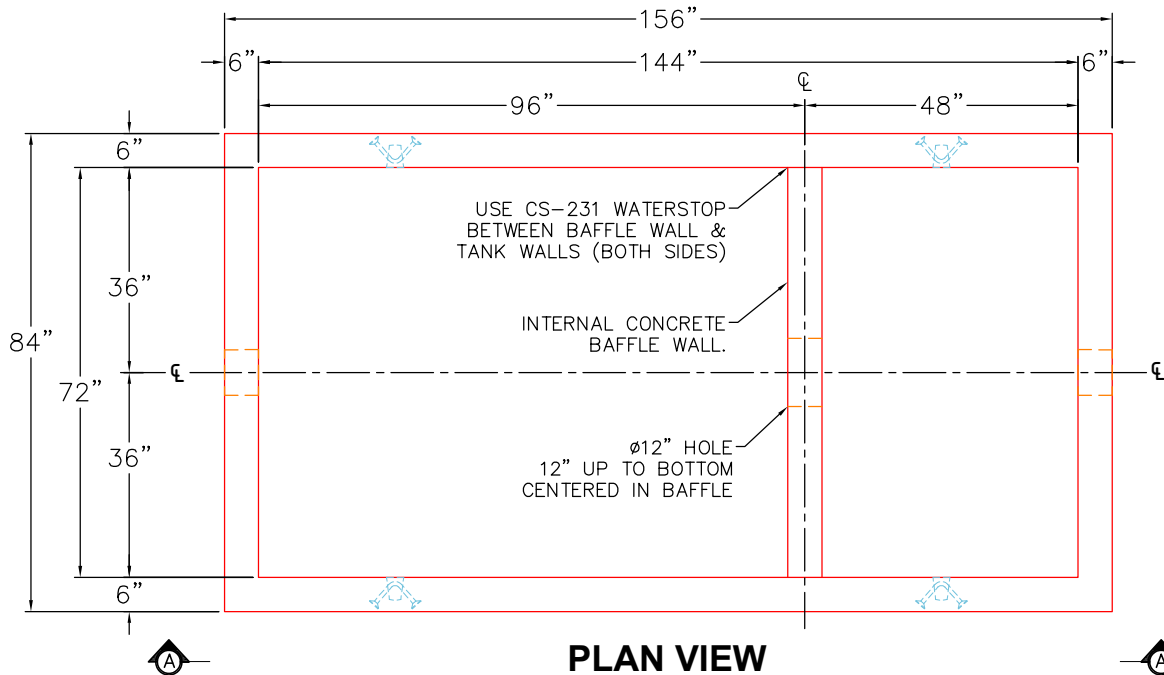

**PLAN VIEW**

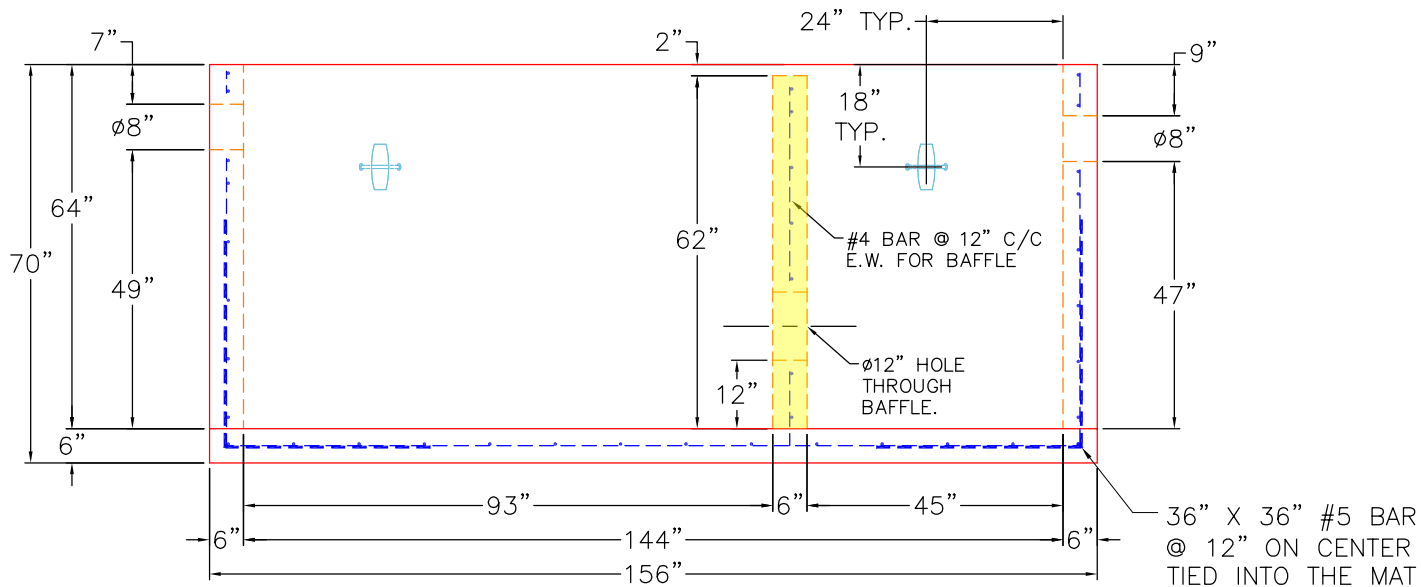

**FRONT VIEW**

**GENERAL NOTES:**

1. MANUFACTURED TO ASTM C-913 (LATEST REVISION).
2. CONCRETE: 4,500 PSI AT 28 DAYS. CONCRETE.
3. REINFORCING: WALLS AND FLOOR #5 BAR @ 12" E.W. O.C. (GRADE 60).
4. WEIGHTS: TOTAL = 23,431 LBS  
 FIRST POUR = 6,598 LBS  
 SECOND POUR = 14,643 LBS  
 THIRD POUR = 2,190 LBS
5. ICAST TO PROVIDE 2X PSX 8QRS DD BOOTS
6. JOINT SEALANT TO BE CONSEAL CS-102, 1".

**THIRD POUR DRAWING**

PRODUCTION WORK ORDER		PRODUCT I.D.: BX072144-06W06F-VFFT	DESCRIPTION: 72" X 144" X 64" TALL 2,000 GAL GREASE TRAP BASE		
	QUALITY CONTROL CHECKLIST	PRODUCT VIEW: RIGHT SIDE UP	CUSTOMER: CORE & MAIN LP		
	<input type="checkbox"/> ALL DIMENSIONS CORRECT.	PLANT: BEAVER DAM, KY.	PROJECT: METRO CENTER GREASE TRAP		
	<input type="checkbox"/> LIFTERS INSTALLED.	WEIGHT: 23,431 LBS.	STRUCTURE: QL1 GT2000 (1)		
	<input type="checkbox"/> HOLE LOCATION(S) CORRECT.	TOP SECTION JOINT: N/A	ORDER NO: 26-2242		
	<input type="checkbox"/> REINFORCING CORRECT.	BASE SECTION JOINT: N/A	PC: T. RYAN	DRAWING: S. FELLETTER	
	<input type="checkbox"/> BAFFLE POURED CORRECTLY.	QC CHECK INITIALS:	DATE: 05/07/26	SCALE: NTS	PG. 1 of 1

Job Name: 26-1228 - L&N Federal Credit Union  
 Job Location: Louisville, KY 40243  
 Contractor: H & W Landworks

Plant: 100

5/6/2026 12:05:19 PM

Tech: Jared - A

PC: T. Lewis



**Structure ID: S-4-5 YD**

**P1 BX1818-06BA24**

**BOX BASE 6inW, 6inF T/n**

- P3) 18" x 18" - CASTING HEIGHT - 4"
- P2) 18" x 18" - BOX RISER 6inW F/G - 12"
- P1) 18" x 18" - BOX BASE 6inW, 6inF T/n - 24"
- 1) CASTING - HOE 165A F/G
- 2) 18" x 18" - Conseal CS-102 1.00"
- 1) Hole - 18

0 lb  
 580 lb  
 1517 lb  
 138 lb  
 0 lb  
 0 lb  
 \_\_\_\_\_  
 0 lb

Structure Total: 2235 lb

Structure Notes:

1. PER LOUISVILLE MSD / ASTM C-913 SPECS
2. CONCRETE: 4,000 PSI AT 28 DAYS
3. REINFORCEMENT: #4 BAR @ 12" C.C. E.W. (GRADE 60) - 2" MIN. REBAR CLEARANCE (TYP)
4. NO STORM INVERT
5. NO STEPS
6. HOE 165-A FRAME & GRATE SUPPLIED BY ICAST

Rim: 747.27' Rim to Invert: 3.47' Slack: 1.64" Sump: 0" Step Position:

Position	Elev	Angle	Ext. (cw)	Pipe	Pipe OD	Connector	Hole	Horz Size	Up ( )	Offset
Invert 1	743.8'	90°	15"	12" ADS N-12	14.5"	Hole 18	18"	18"	-1.25"	0"
Invert 2										
Invert 3										
Invert 4										
Invert 5										
Invert 6										
Invert 7										
Invert 8										

RIGHT-SIDE UP VIEW (int. dimensions)

UPSIDE-DOWN VIEW (int. dimenions)

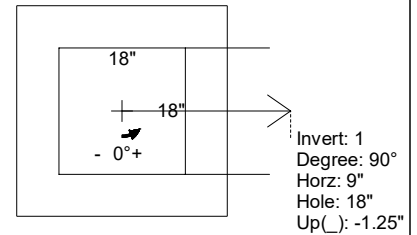
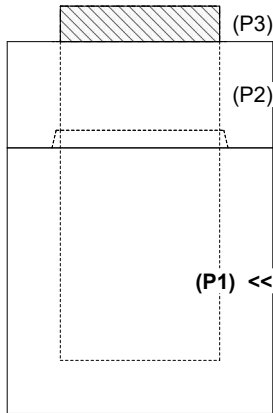

INSIDE WALL DIMENSIONS

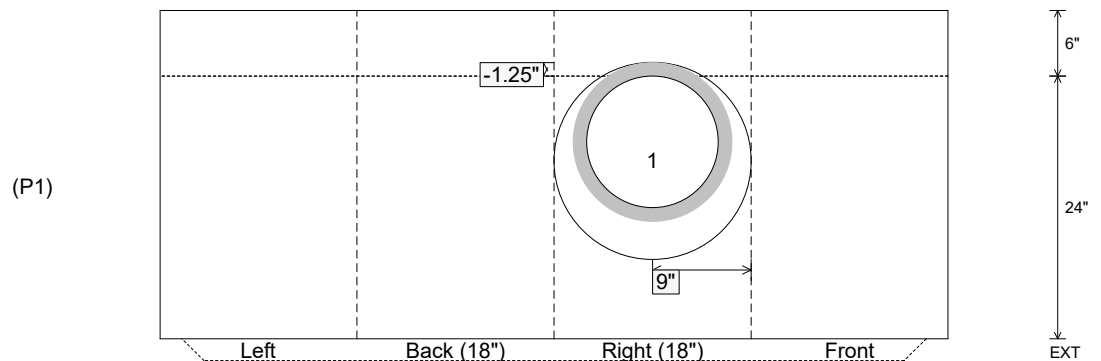

Coating (Int):  
 Coating (Ext):

Seam Up: Tongue  
 Seam Dn: n/a

Wall Thickness: 6"  
 Floor Height: 6"

Height (Int): 24"  
 Height (Ext): 30"

Weight (Net): 1517 lb  
 Volume (Net): 0.39cu.yd

Job Name: 26-1232 - Mustang Village Apartments Ph.1  
 Job Location: Paducah, KY  
 Contractor: Wood Brothers

Plant: 100  
 4/21/2026 8:03:21 PM

Tech: Jared - F  
 PC: T. Lewis



**Structure ID: S33-33 ST-DBI**

**P1 BX2424-08BAVF**

**BOX BASE 8inW, 8inF, Variable Ht F/n**

- P2) 24" x 24" - CASTING HEIGHT - 0"
- P1) 24" x 24" - BOX BASE 8inW, 8inF, Variable Ht F/n - 34"
- 1) CASTING - HOE HOE-315 ANGLE F/G
- 1) 24" x 24" - Conseal CS-102 1.00"
- 2) Hole - 20

0 lb  
 3526 lb  
 258 lb  
 0 lb  
 0 lb  
 -----  
 0 lb  
 Structure Total: 3784 lb

- Structure Notes:
1. PER ASTM C913 SPECIFICATIONS.
  2. CONCRETE = 4,000 PSI AT 28 DAYS.
  3. NO STEPS AND NO INVERT CHANNEL.
  4. CASTING BY ICAST (HOE-315 ANGLE F/G)

REINFORCING PER ASTM A615 (GRADE 60).  
 - WALLS (As .12) #5 BARS AT 12" C.C.E.W.  
 - FLOOR (As .12) #5 BARS AT 12" C.C.E.W.

Rim: 382.62' Rim to Invert: 2.9' Slack: 0.8" Sump: 0" Step Position:

Position	Elev	Angle	Ext. (cw)	Pipe	Pipe OD	Connector	Hole	Horz Size	Up ( )	Offset
Invert 1	379.72'	0°	20"	15" HDPE	17.6"	Hole 20	20"	20"	-1.25"	0"
Invert 2	379.72'	125°	25.875"	15" HDPE	17.6"	Hole 20	20"	23.995", 0.6"	-1.25"	-6.709"
Invert 3										
Invert 4										
Invert 5										
Invert 6										
Invert 7										
Invert 8										

RIGHT-SIDE UP VIEW (int. dimensions)

UPSIDE-DOWN VIEW (int. dimensions)

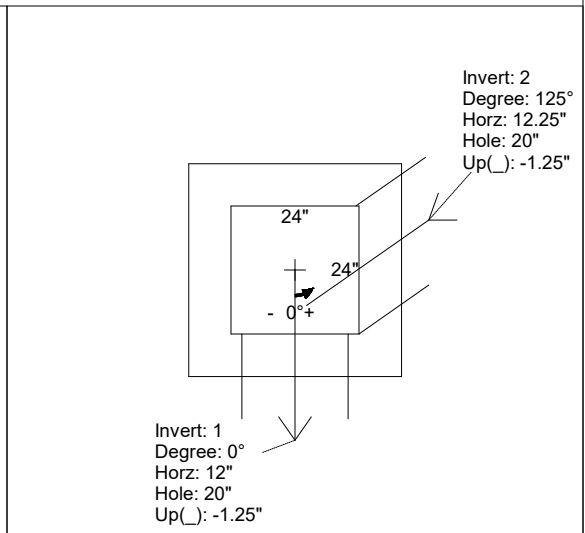
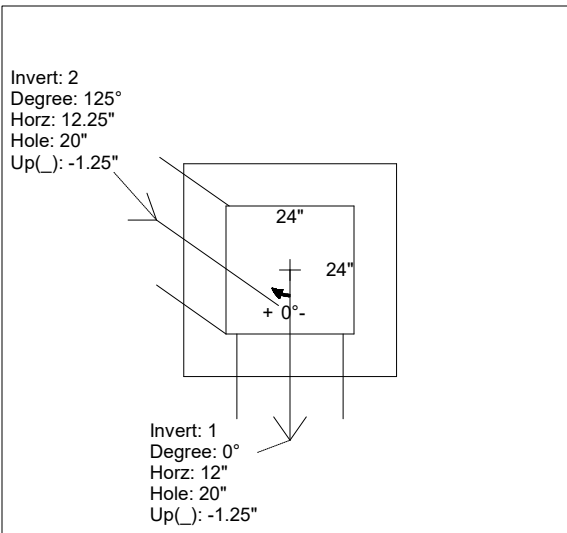
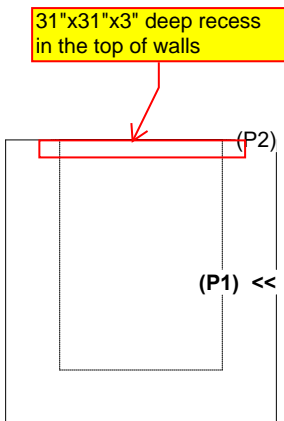

INSIDE WALL DIMENSIONS

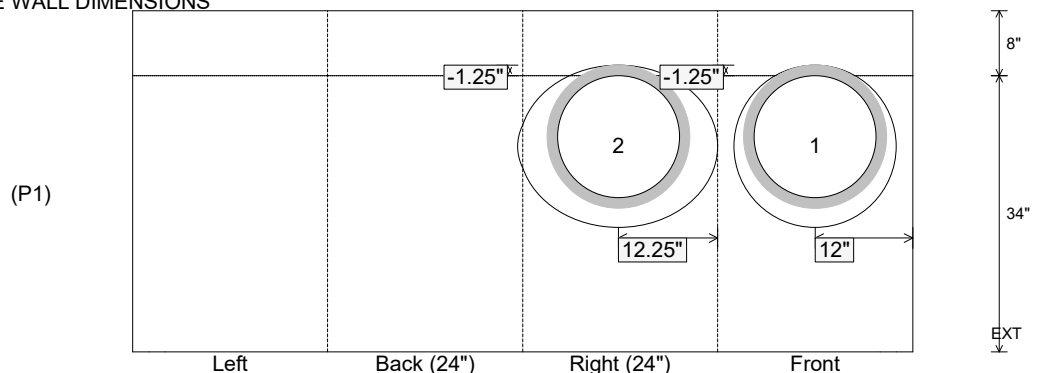

Coating (Int):  
 Coating (Ext):

Seam Up: Flat  
 Seam Dn: n/a

Wall Thickness: 8"  
 Floor Height: 8"

Height (Int): 34"  
 Height (Ext): 42"

Weight (Net): 3526 lb  
 Volume (Net): 0.9cu.yd

Job Name: 26-1232 - Mustang Village Apartments Ph.1  
 Job Location: Paducah, KY  
 Contractor: Wood Brothers

Plant: 100  
 4/21/2026 8:03:18 PM

Tech: Jared - F  
 PC: T. Lewis



**Structure ID: S29-29 DBI13G**

**P1 BX3636-08BA60**

**BOX BASE 8inW, 8inF F/n**

- P3) 15" x 27" - P.I.P. - BY OTHERS - 8"
- P2) 36" x 36" - CB FT REDUCER 15"X27" HOLE T/F - 8"
- P1) 36" x 36" - BOX BASE 8inW, 8inF F/n - 60"
- 1) CASTING - HOE KY-230-G F/G (GRADE)
- 1) 36" x 36" - Conseal CS-102 1.00"
- 1) 15" x 27" - Conseal CS-102 1.00"
- 1) Hole - 30
- 1) Hole - 18
- 1) Hole - 24
- 2) Hole - 4

0 lb  
 1543 lb  
 7889 lb  
 237 lb  
 0 lb  
 0 lb  
 0 lb  
 0 lb  
 0 lb  
 0 lb  
 0 lb  
 -----  
 Structure Total: 9669 lb

**Structure Notes:**  
 1. KYTC DBI TYPE 13G / ASTM C-913 SPEC'S.  
 2. CONCRETE = 4,000 PSI AT 28 DAYS.  
 3. CASTING BY ICAST (HOE KY-230-G F/G (GRADE)).

REINFORCING PER ASTM A615 (GRADE 60).  
 - TRANS. SLAB (As .62) #5 BARS AT 6" C.C.E.W. (DBL MAT).  
 - WALLS (As .31) #5 BARS AT 12" C.C.E.W..  
 - FLOOR (As .31) #5 BARS AT 12" C.C.E.W.

Rim: 379.93' Rim to Invert: 6.55' Slack: 2.6" Sump: 0" Step Position:

Position	Elev	Angle	Ext. (cw)	Pipe	Pipe OD	Connector	Hole	Horz Size	Up ( )	Offset
Invert 1	373.38'	335°	22.375"	24" HDPE	27.8"	Hole 30	30"	33.101"	-1.875"	7.75"
Invert 2	376.09'	90°	26"	12" HDPE	14.5"	Hole 18	18"	18"	31.25"	0"
Invert 3	373.38'	180°	26"	18" HDPE	21.2"	Hole 24	24"	24"	-1.625"	0"
Invert 4	377.71'	0°	26"	4" WEEP HOLE	4"	Hole 4	4"	4"	52"	0"
Invert 5	377.71'	180°	26"	4" WEEP HOLE	4"	Hole 4	4"	4"	52"	0"
Invert 6										
Invert 7										
Invert 8										

RIGHT-SIDE UP VIEW (int. dimensions)

UPSIDE-DOWN VIEW (int. dimensions)

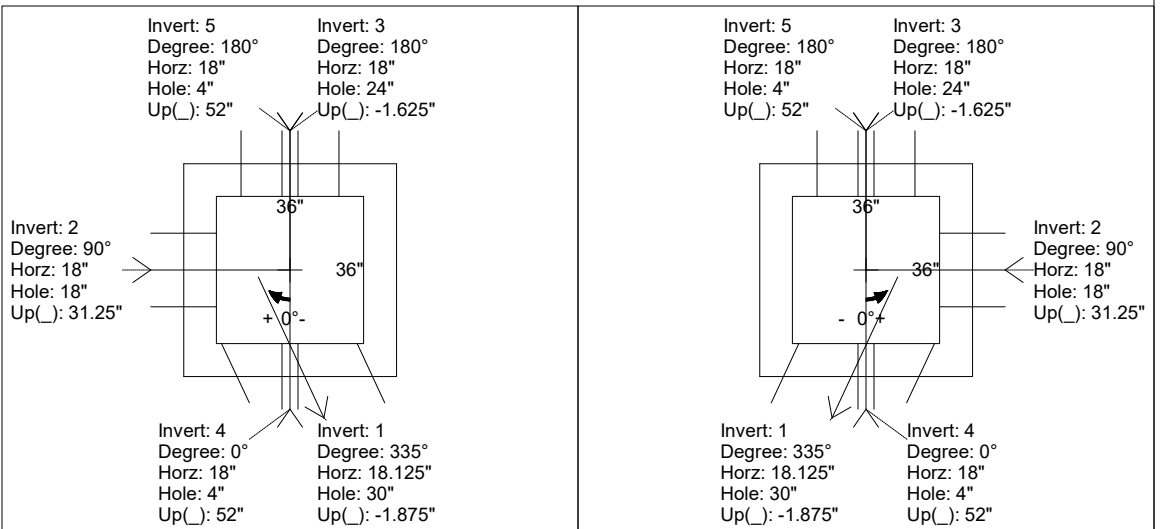

INSIDE WALL DIMENSIONS

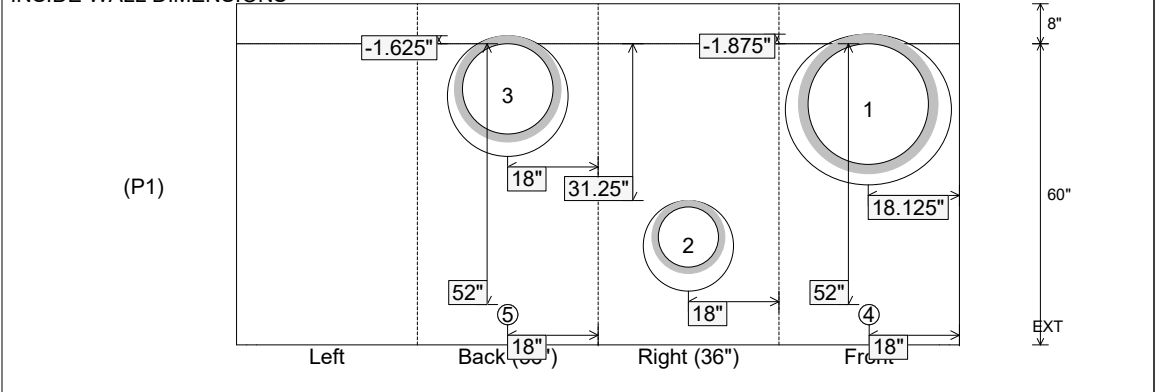

Coating (Int): Coating (Ext):	Seam Up: Flat Seam Dn: n/a	Wall Thickness: 8" Floor Height: 8"	Height (Int): 60" Height (Ext): 68"	Weight (Net): 7889 lb Volume (Net): 2.02cu.yd
----------------------------------	-------------------------------	--	--	--

Job Name: 25-1431 - Georgetown Commons  
 Job Location: Georgetown, KY  
 Contractor: Winwater Hartford KY Co.

Plant: Beaver Dam

4/23/2026 11:19:54 AM

Tech: J. Coppage

PC: A. Chambers



**Structure ID: SCI 40**

**P1 BX24300808VF**

**BOX BASE 8inW, 8inF, Variable Ht**

- P2) 24" x 24" - CASTING HEIGHT - 6"
- P1) 24" x 30" - BOX BASE 8inW, 8inF, Variable Ht - 33"
- 1) CASTING - HOE 360 Set (F/G/H)
- 1) 24" x 30" - SGL 1"x14.5' Butyl
- 1) Hole - 18

- Structure Notes:
1. JR HOE HOE-360 PROVIDED BY ICAST.
  2. PER ASTM C913 SPECIFICATIONS.
  3. CONCRETE = 4,000 PSI AT 28 DAYS.
  4. REINFORCING PER ASTM A615 (GRADE 60).  
 - WALLS (As .12) #5 BARS AT 12" C.C.E.W.  
 - FLOOR (As .31) #5 BARS AT 12" C.C.E.W.

Structure Total: 4528 lb

Rim: 867.35' Rim to Invert: 3.35' Slack: 2.45" Sump: 1.25" Step Position:

Position	Elev	Angle	Ext. (cw)	Pipe	Pipe OD	Connector	Hole	Horz Size	Up ( )	Offset
Invert 1	864'	270°	23"	12" HDPE	14.5"	Hole 18	18"	18"	0"	0"
Invert 2										
Invert 3										
Invert 4										
Invert 5										
Invert 6										
Invert 7										
Invert 8										

RIGHT-SIDE UP VIEW (int. dimensions)

UPSIDE-DOWN VIEW (int. dimensions)

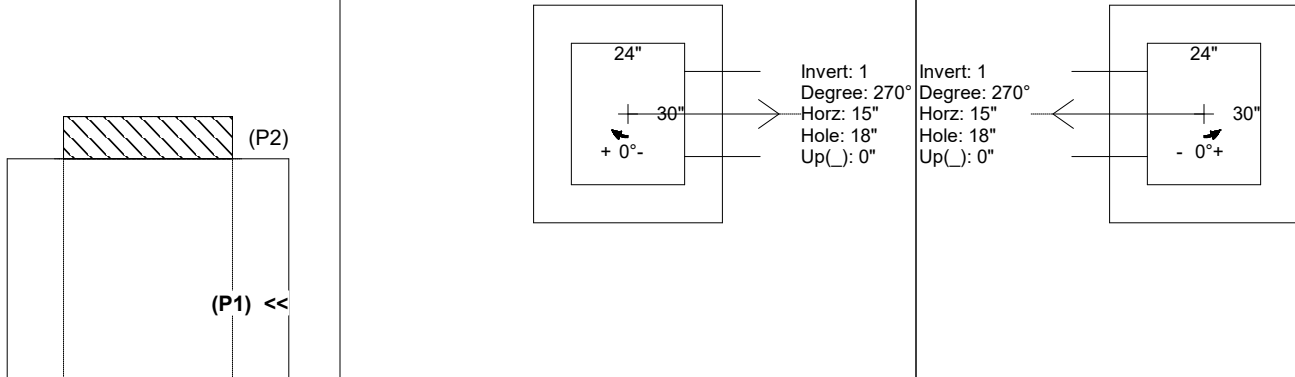

INSIDE WALL DIMENSIONS

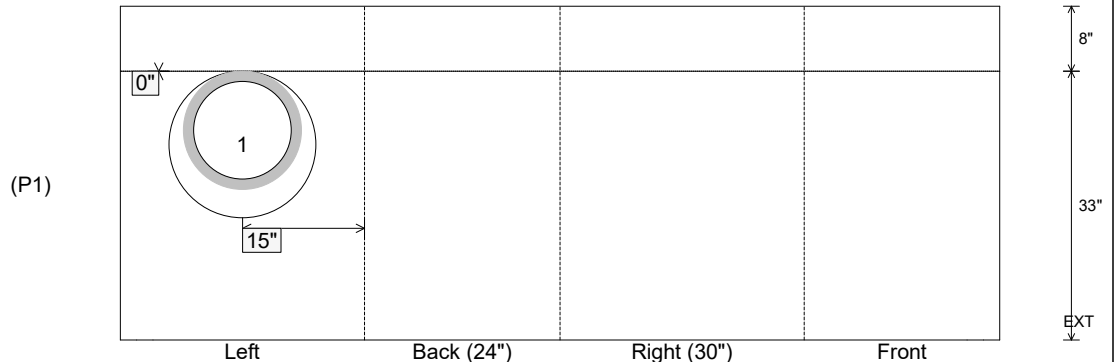

Coating (Int):  
 Coating (Ext):

Seam Up: Flat  
 Seam Dn: n/a

Wall Thickness: 8"  
 Floor Height: 8"

Height (Int): 33"  
 Height (Ext): 41"

Weight (Net): 4166 lb  
 Volume (Net): 1.06cu.yd

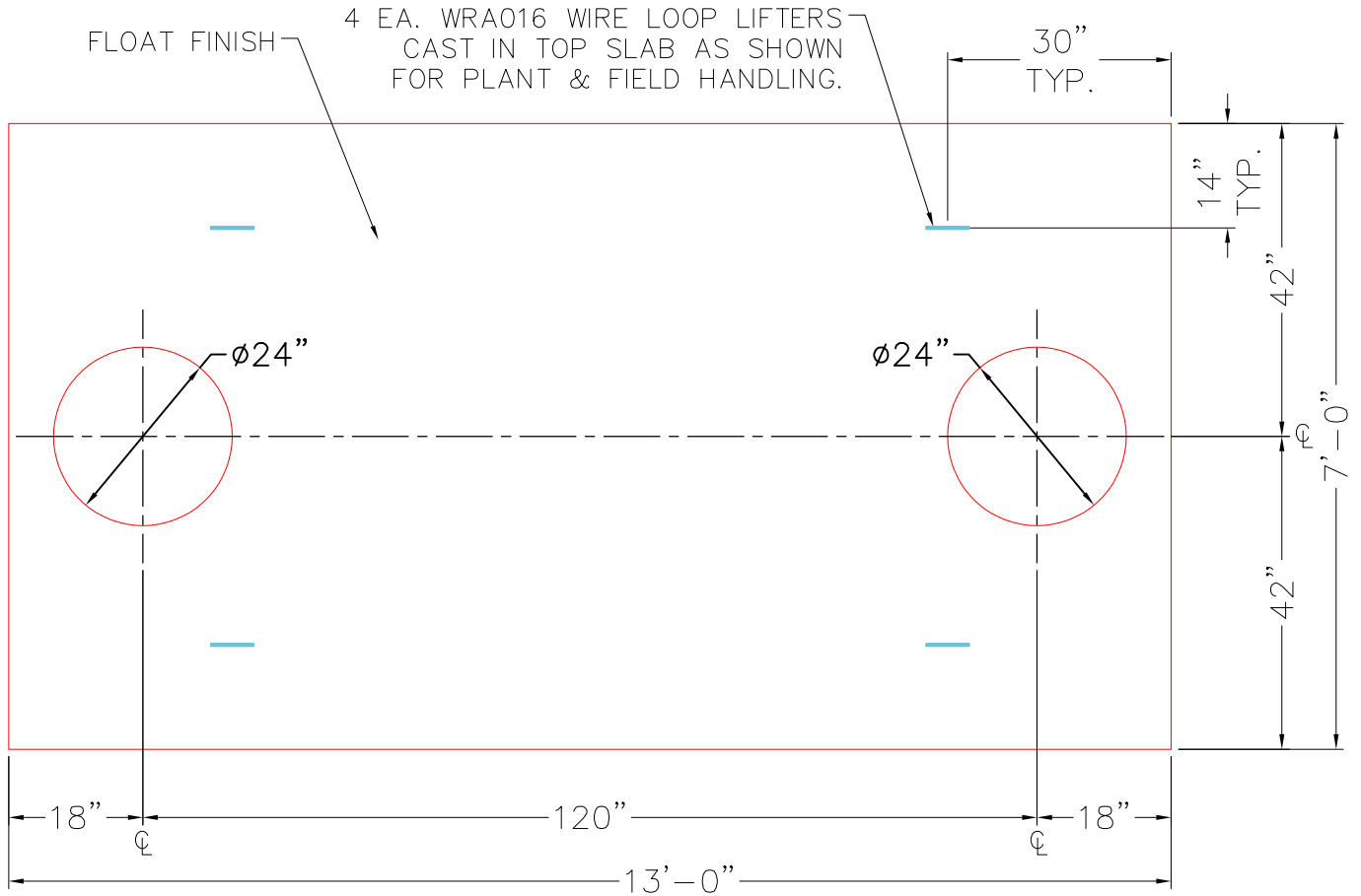

**TOP VIEW**

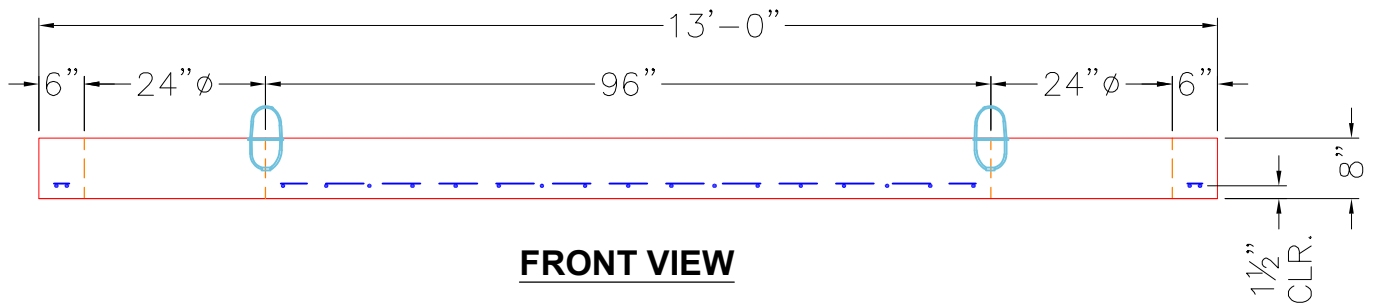

**FRONT VIEW**

**NOTES:**

1. PER ASTM C-890-13 LATEST REVISION.  
(H-20 TRAFFIC RATED DESIGN)
2. CONCRETE = 5,000 PSI AT 28 DAYS.
3. REINFORCING: #5 BAR @ 8" C/C E.W. (GRADE 60).  
PER ASTM A615

PRODUCTION WORK ORDER		PRODUCT I.D.: BX072177-08LD06S	DESCRIPTION: 84" X 156" X 8" GREASE TRAP TOP SLAB		
	QUALITY CONTROL CHECKLIST	PRODUCT VIEW: RIGHT SIDE UP	CUSTOMER: CORE & MAIN LP		
	<input type="checkbox"/> ALL DIMENSIONS CORRECT.	PLANT: BEAVER DAM, KY.	PROJECT: GUTHRIE KY. CONVENIENCE STORE		
	<input type="checkbox"/> LIFTERS INSTALLED.	WEIGHT: 8,475 LBS.	STRUCTURE: 1,500 GAL GREASE TRAP		
	<input type="checkbox"/> HOLE LOCATION(S) CORRECT.	TOP SECTION JOINT: N/A	ORDER NO: 25-2023		
	<input type="checkbox"/> REINFORCING CORRECT.	BASE SECTION JOINT: N/A	PC: T. LEWIS	DRAWING: S. FELLETTER	
	<input type="checkbox"/> FLAT ON BOTTOM OF SLAB.	QC CHECK INITIALS:	DATE: 05/05/26	SCALE: NTS	PG. 1 of 1
<input type="checkbox"/> LIGHT BRUSHED FINISH.					
<input type="checkbox"/> SURFACE QUALITY ACCEPTABLE.					

Job Name: 26-1232 - Mustang Village Apartments Ph.1  
 Job Location: Paducah, KY  
 Contractor: Wood Brothers

Plant: 100  
 4/21/2026 8:04:33 PM

Tech: Jared - F  
 PC: T. Lewis



**Structure ID: S37-37 DBI13G**

**P2 BX024036-08TS015027**

**CB FT REDUCER 15"X27" HOLE T/F**

- P3) 15" x 27" - P.I.P. - BY OTHERS - 8"
- P2) 24" x 36" - CB FT REDUCER 15"X27" HOLE F/F - 8"
- P1) 24" x 36" - BOX BASE 8inW, 8inF, Variable Ht F/n - 34"
- 1) CASTING - HOE KY-230-G F/G (GRADE)
- 1) 24" x 36" - Conseal CS-102 1.00"
- 1) 15" x 27" - Conseal CS-102 1.00"
- 2) Hole - 18
- 2) Hole - 4

0 lb  
 1124 lb  
 4469 lb  
 237 lb  
 0 lb  
 0 lb  
 0 lb  
 0 lb  
 Structure Total: 5831 lb

**Structure Notes:**  
 1. KYTC DBI TYPE 13G / ASTM C-913 SPEC'S.  
 2. CONCRETE = 4,000 PSI AT 28 DAYS.  
 3. CASTING BY ICAST (HOE KY-230-G F/G (GRADE)).

REINFORCING PER ASTM A615 (GRADE 60).  
 - TRANS. SLAB (As .62) #5 BARS AT 6" C.C.E.W. (DBL MAT).  
 - WALLS (As .31) #5 BARS AT 12" C.C.E.W..  
 - FLOOR (As .31) #5 BARS AT 12" C.C.E.W.

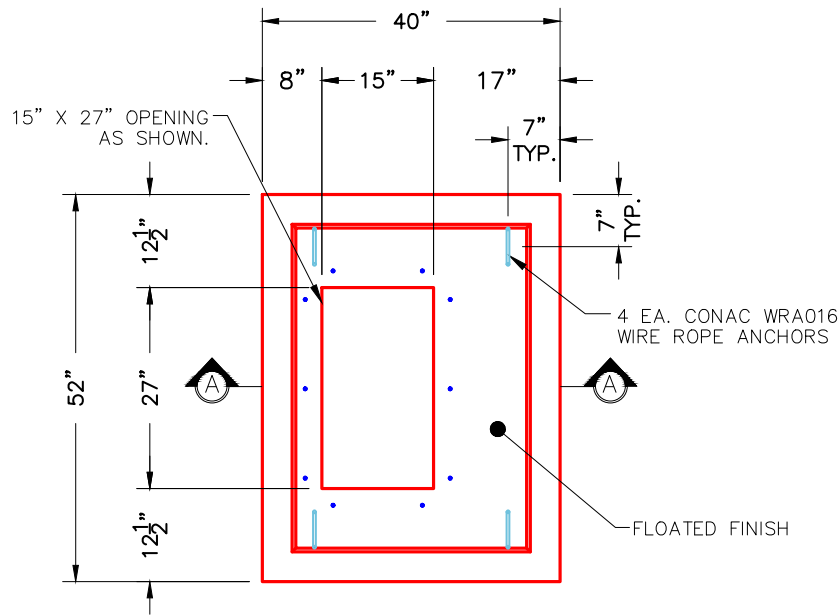

**PLAN VIEW**

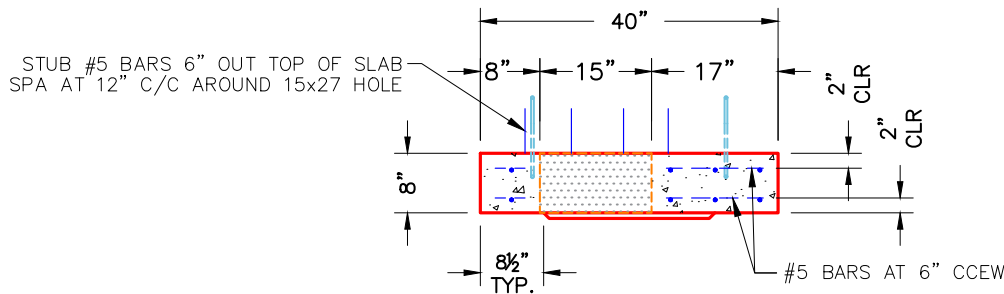

**SECTION A-A**

**NOTES:**

1. MANUFACTURED TO ASTM C-913 (LATEST REVISION).
2. CONCRETE: 4,000 PSI AT 28 DAYS.
3. REINFORCING: #5 BAR @ 6" O.C. E.W. (DOUBLE MAT) (GRADE 60).

Coating (Int):  
 Coating (Ext):

Seam Up: Flat  
 Seam Dn: Flat

Wall Thickness: 8"

Height (Ext): 8"

Weight (Net): 1124 lb  
 Volume (Net): 0.29cu.yd

Job Name: 26-1232 - Mustang Village Apartments Ph.1  
 Job Location: Paducah, KY  
 Contractor: Wood Brothers

Plant: 100  
 4/21/2026 8:04:32 PM

Tech: Jared - F  
 PC: T. Lewis



**Structure ID: S31-31 DBI13G**

**P2 BX036036-08TS015027**

**CB FT REDUCER 15"X27" HOLE T/F**

- P3) 15" x 27" - P.I.P. - BY OTHERS - 8"
- P2) 36" x 36" - CB FT REDUCER 15"X27" HOLE F/F - 8"
- P1) 36" x 36" - BOX BASE 8inW, 8inF, Variable Ht F/n - 53"
- 1) CASTING - HOE KY-230-G F/G (GRADE)
- 1) 36" x 36" - Conseal CS-102 1.00"
- 1) 15" x 27" - Conseal CS-102 1.00"
- 2) Hole - 24
- 1) Hole - 18
- 2) Hole - 4

0 lb  
 1543 lb  
 7251 lb  
 237 lb  
 0 lb  
 0 lb  
 0 lb  
 0 lb  
 0 lb  
 0 lb  
 Structure Total: 9031 lb

**Structure Notes:**  
 1. KYTC DBI TYPE 13G / ASTM C-913 SPEC'S.  
 2. CONCRETE = 4,000 PSI AT 28 DAYS.  
 3. CASTING BY ICAST (HOE KY-230-G F/G (GRADE)).

REINFORCING PER ASTM A615 (GRADE 60).  
 - TRANS. SLAB (As .62) #5 BARS AT 6" C.C.E.W. (DBL MAT).  
 - WALLS (As .31) #5 BARS AT 12" C.C.E.W..  
 - FLOOR (As .31) #5 BARS AT 12" C.C.E.W.

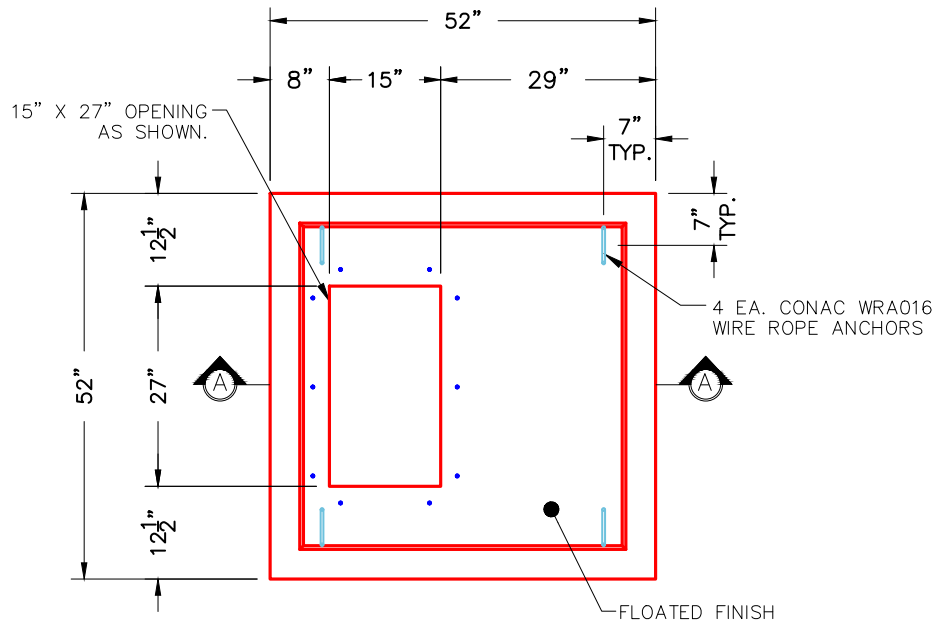

**PLAN VIEW**

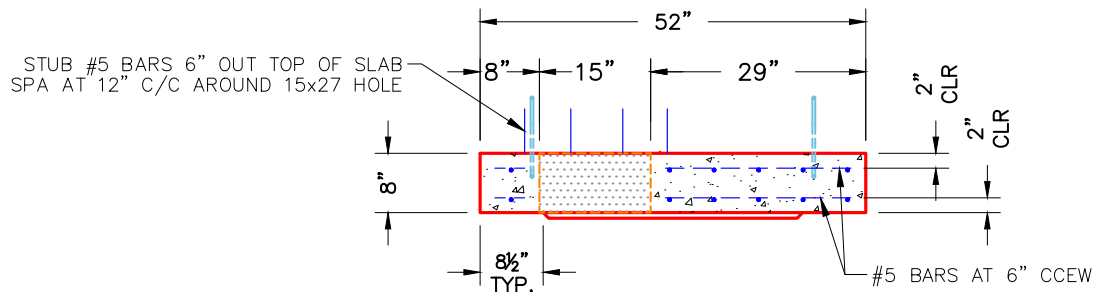

**SECTION A-A**

**NOTES:**

- 1. MANUFACTURED TO ASTM C-913 (LATEST REVISION).
- 2. CONCRETE: 4,000 PSI AT 28 DAYS.
- 3. REINFORCING: #5 BAR @ 6" O.C. E.W. (DOUBLE MAT) (GRADE 60).

Coating (Int):  
 Coating (Ext):

Seam Up: Flat  
 Seam Dn: Flat

Wall Thickness: 8"

Height (Ext): 8"

Weight (Net): 1543 lb  
 Volume (Net): 0.39cu.yd

Job Name: 26-1582 - Wyelea Commons Water Vault  
 Job Location: Franklin, TN  
 Contractor: Core & Main LP

Plant: 100

5/1/2026 1:12:54 PM

Tech: Jared - A

PC: T. Lewis



**Structure ID: 2 (3)**

**P1 BX7296-06W06F-BA42**

**BOX BASE 6inW, 6inF T/n**

P4) 48" x 72" - HATCH (CAST FLUSH) - 3"	0 lb
P3) 72" x 96" - CB FLAT TOP 6"W w/48"x72" HATCH F/F - 6"	3000 lb
P2) 72" x 96" - BOX RISER 6inW, Variable Ht FT F/G - 30"	5437 lb
P1) 72" x 96" - BOX BASE 6inW, 6inF T/n - 42"	12041 lb
1) This Structure Includes a Cast-in Item - 48" X 72" Hatch (Supplied by Others)	0 lb
1) This Structure Includes a Cast-in Item - M.A. Industries Sump Pan & Lid (Supplied by iCast)	0 lb
1) SUMP DISH - M.A. Industries Sump Pan & Lid	0 lb
2) 72" x 96" - Conseal CS-102 1.00" (Double)	0 lb
2) Hole - 12	0 lb
6) MH Step ML-10-TDS-NCR - 10"	0 lb
<b>Structure Total:</b>	<b>20478 lb</b>

- Structure Notes:**
- PER ASTM C-913 SPECIFICATIONS
  - CONCRETE: 5,000 PSI AT 28 DAYS
  - REINFORCEMENT: #4 BAR @ 8" C.C. E.W. (GRADE 60) - 2" MIN. REBAR CLEARANCE (TYP)
  - STEPS AT 270 DEGREES
  - M.A. INDUSTRIES SUMP PAN & LID SUPPLIED BY ICAS - TO BE CAST INTO BASE FLOOR
  - 8" DIA. OPENING REQUIRED IN BASE FLOOR FOR 4" PVC FLOOR DRAIN
  - LIFTERS: 4 EA. 5CA14 CONAC A-ANCHORS FOR PLANT & FIELD HANDLING - INSTALLED AS SHOWN

Rim: 6.5' Rim to Invert: 4.75' Slack: 0" Sump: 21" Step Position: 270°

Position	Elev	Angle	Ext. (cw)	Pipe	Pipe OD	Connector	Hole	Horz Size	Up (L)	Offset
Invert 1	1.75'	0°	42"	8" DI	9"	Hole 12	12"	12"	19"	0"
Invert 2	1.75'	180°	42"	8" DI	9"	Hole 12	12"	12"	19"	0"
Invert 3										

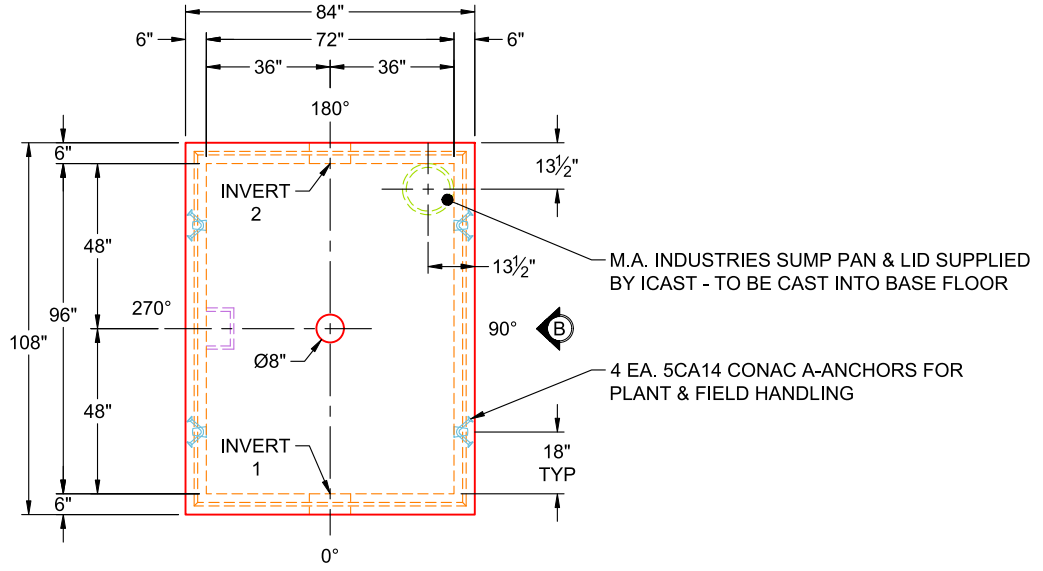
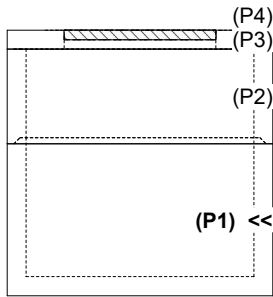

**PLAN VIEW (UPSIDE DOWN)**

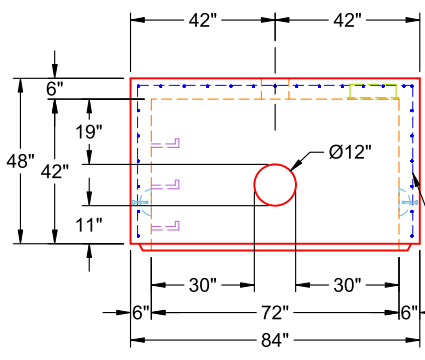

**VIEW A (UPSIDE DOWN)**

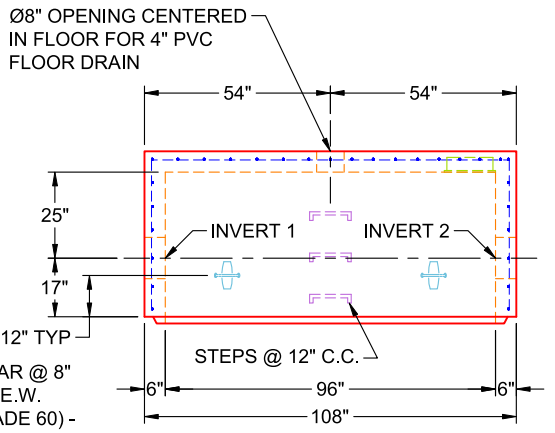

**VIEW B (UPSIDE DOWN)**

Coating (Int): Coating (Ext):	Seam Up: Tongue Seam Dn: n/a	Wall Thickness: 6" Floor Height: 6"	Height (Int): 42" Height (Ext): 48"	Weight (Net): 12041 lb Volume (Net): 3.08cu.yd
----------------------------------	---------------------------------	--	--	---

**Job Number:**

26-1582

**Job Name:**

Wyelea Commons Water Vault

**Structure:**

2 (3)

**Note:**

M.A. Industries Sump Pan & Lid  
Supplied By iCast To Be Cast Into  
Base Floor

Job Name: 26-1582 - Wyelea Commons Water Vault  
 Job Location: Franklin, TN  
 Contractor: Core & Main LP

Plant: 100

Tech: Jared - A

5/1/2026 1:13:20 PM

PC: T. Lewis



**Structure ID: 2 (2)**

**P3 BX072096-06LD06S**

**CB FLAT TOP 6"W w/48"x72" HATCH F/F**

- P4) 48" x 72" - HATCH (CAST FLUSH) - 3"
- P3) 72" x 96" - CB FLAT TOP 6"W w/48"x72" HATCH F/F - 6"
- P2) 72" x 96" - BOX RISER 6inW, Variable Ht FT F/G - 30"
- P1) 72" x 96" - BOX BASE 6inW, 6inF T/n - 42"
- 1) This Structure Includes a Cast-in Item - 48" X 72" Hatch (Supplied by Others)
- 1) This Structure Includes a Cast-in Item - M.A. Industries Sump Pan & Lid (Supplied by iCast)
- 1) SUMP DISH - M.A. Industries Sump Pan & Lid
- 2) 72" x 96" - Conseal CS-102 1.00" (Double)
- 2) Hole - 12
- 6) MH Step ML-10-TDS-NCR - 10"

0 lb  
 3000 lb  
 5437 lb  
 12041 lb  
 0 lb  
 0 lb  
 0 lb  
 0 lb  
 0 lb  
 0 lb  
 0 lb  
 20478 lb

- Structure Notes:**
1. PER ASTM C-913 SPECIFICATIONS
  2. CONCRETE: 5,000 PSI AT 28 DAYS
  3. REINFORCEMENT: #4 BAR @ 6" C.C. E.W. (GRADE 60) - 2" MIN. REBAR CLEARANCE (TYP)
  4. 48" X 72" HATCH SUPPLIED BY OTHERS - TO BE CAST INTO FLAT LID
  5. LIFTERS: 4 EA. 5CA14 CONAC A-ANCHORS FOR PLANT & FIELD HANDLING - INSTALLED AS SHOWN
  6. TOP SURFACE TO RECEIVE LIGHT BRUSH FINISH

Structure Total:

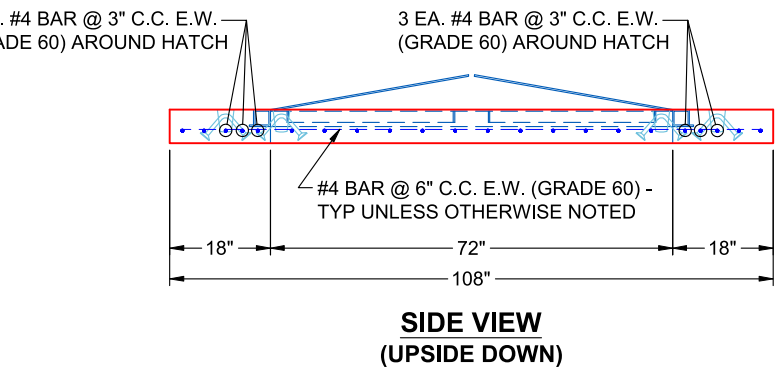
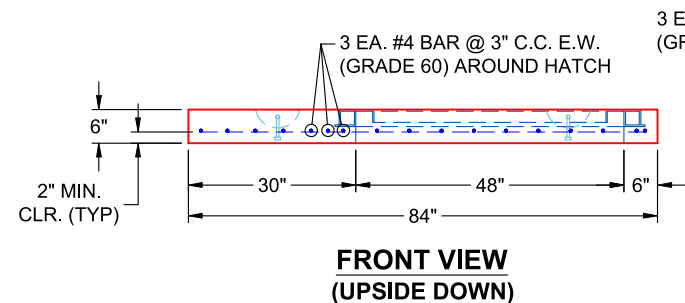
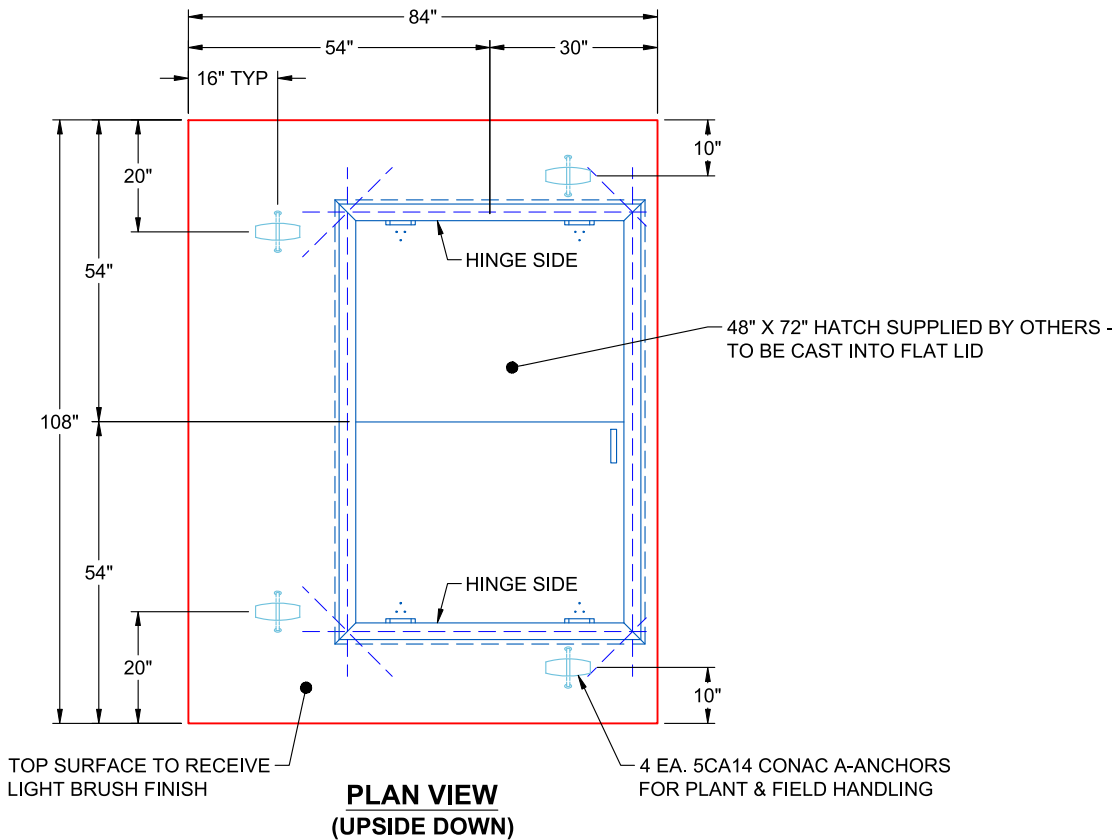

Coating (Int): Coating (Ext):	Seam Up: Flat Seam Dn: Flat	Wall Thickness: 6"	Height (Ext): 6"	Weight (Net): 3000 lb Volume (Net): 0.77cu.yd
----------------------------------	--------------------------------	--------------------	------------------	--

**Job Number:**

26-1582

**Job Name:**

Wyelea Commons Water Vault

**Structure:**

2 (2)

**Note:**

48" x 72" Hatch Supplied By Others  
To Be Cast Into Flat Lid

Job Name: 26-1582 - Wyelea Commons Water Vault  
 Job Location: Franklin, TN  
 Contractor: Core & Main LP

Plant: 100

5/1/2026 1:13:19 PM

Tech: Jared - A

PC: T. Lewis



**Structure ID: 2 (1)**

**P3 BX072096-06LD06S**

**CB FLAT TOP 6"W w/48"x72" HATCH F/F**

- P4) 48" x 72" - HATCH (CAST FLUSH) - 3"
- P3) 72" x 96" - CB FLAT TOP 6"W w/48"x72" HATCH F/F - 6"
- P2) 72" x 96" - BOX RISER 6inW, Variable Ht FT F/G - 30"
- P1) 72" x 96" - BOX BASE 6inW, 6inF T/n - 42"
- 1) This Structure Includes a Cast-in Item - 48" X 72" Hatch (Supplied by Others)
- 1) This Structure Includes a Cast-in Item - M.A. Industries Sump Pan & Lid (Supplied by iCast)
- 1) SUMP DISH - M.A. Industries Sump Pan & Lid
- 2) 72" x 96" - Conseal CS-102 1.00" (Double)
- 2) Hole - 12
- 6) MH Step ML-10-TDS-NCR - 10"

Structure Total: 20478 lb

Structure Notes:

1. PER ASTM C-913 SPECIFICATIONS
2. CONCRETE: 5,000 PSI AT 28 DAYS
3. REINFORCEMENT: #4 BAR @ 6" C.C. E.W. (GRADE 60) - 2" MIN. REBAR CLEARANCE (TYP)
4. 48" X 72" HATCH SUPPLIED BY OTHERS - TO BE CAST INTO FLAT LID
5. LIFTERS: 4 EA. 5CA14 CONAC A-ANCHORS FOR PLANT & FIELD HANDLING - INSTALLED AS SHOWN
6. TOP SURFACE TO RECEIVE LIGHT BRUSH FINISH

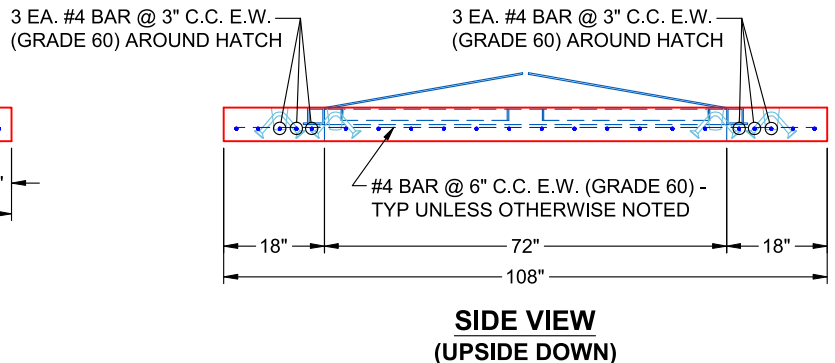
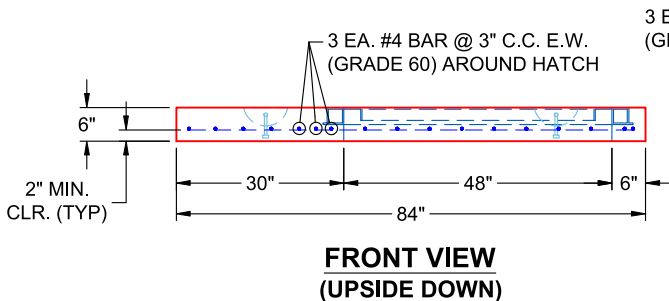
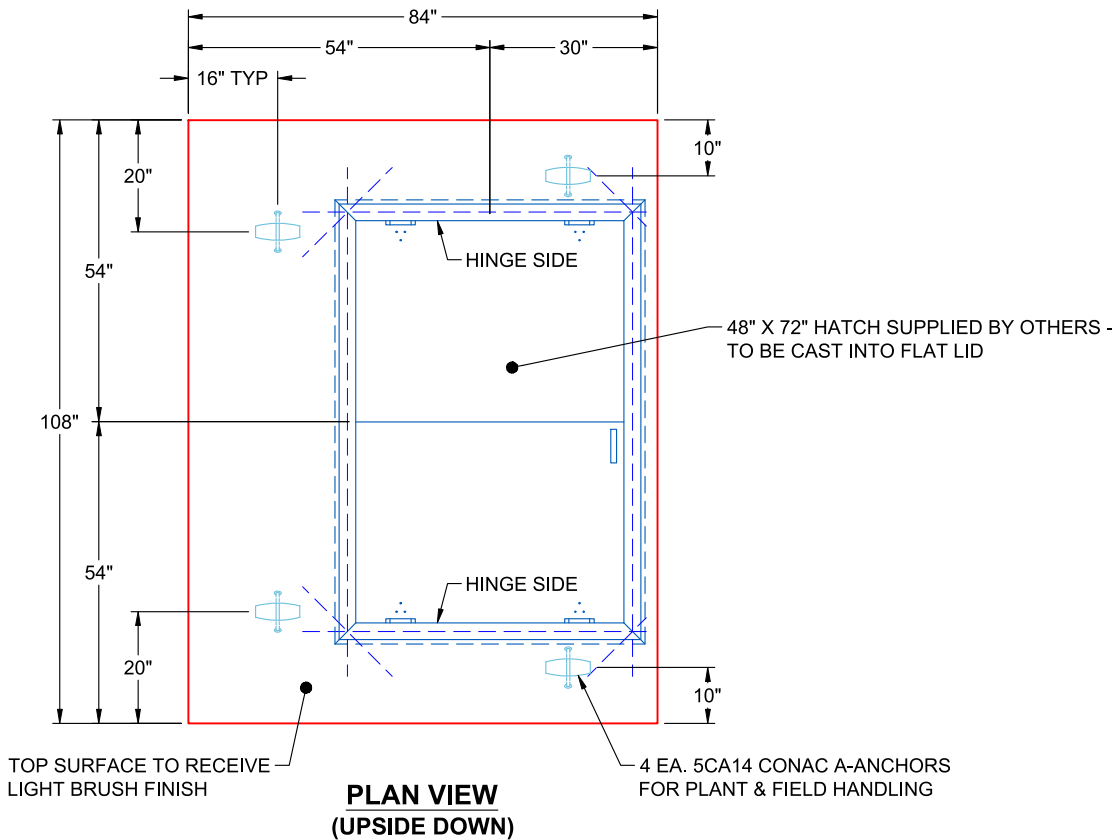

Coating (Int):  
Coating (Ext):

Seam Up: Flat  
Seam Dn: Flat

Wall Thickness: 6"

Height (Ext): 6"

Weight (Net): 3000 lb  
Volume (Net): 0.77cu.yd

**Job Number:**

26-1582

**Job Name:**

Wyelea Commons Water Vault

**Structure:**

2 (1)

**Note:**

48" x 72" Hatch Supplied By Others  
To Be Cast Into Flat Lid

Job Name: 25-3531 - Crescent Hill Filtration Plant Carbon Storage  
 Job Location: Louisville, KY  
 Contractor: Dugan & Meyers, LLC

Plant: Beaver Dam, KY  
 3/30/2026 9:45:21 AM

Tech: K. Cardwell  
 PC: J. Jarvis



**Structure ID: V-005**

**P3 BX60120-08LD08-S**

**BX FLAT TOP 8"W w/60"x120" HATCH**

- P4) 60" x 120" - HATCH (CAST FLUSH) - 3"
- P3) 60" x 120" - BX FLAT TOP 8"W w/60"x120" HATCH - 8"
- P2) 60" x 120" - BOX RISER 8inW, Variable Ht - 27"
- P1) 60" x 120" - BOX BASE 8inW, 8inF, Variable Ht - 31"
- 1) HATCH (Alum.) - HALLIDAY H2R 48"x48"
- 1) This Structure Includes a Cast-In Item (Hatch)
- 3) 60" x 120" - Conseal CS-102 1.00"
- 8) Hole - 6.5
- 5) MH Step ML-10-TDS-NCR - 10"

100 lb  
 2105 lb  
 7105 lb  
 14918 lb  
 235 lb  
 0 lb  
 0 lb  
 0 lb  
 0 lb  
 -----  
 Structure Total: 24463 lb

**Structure Notes:**  
 1. PER ASTM C913 SPECIFICATIONS.  
 2. CONCRETE = 4,000 PSI AT 28 DAYS.  
 3. NO INVERT CHANNEL.  
  
 REINFORCING PER ASTM A615 (GRADE 60).  
 - TOP SLAB (As .62) #5 BARS AT 6" C.C.E.W.  
 - WALLS (As .31) #5 BARS AT 12" C.C.E.W.  
 - FLOOR (As .31) #5 BARS AT 12" C.C.E.W.

**GENERAL NOTES:**

1. MANUFACTURED TO ASTM C-913 (LATEST REVISION) & DESIGNED TO MEET ASTM C857 & ACI 318 REQUIREMENTS.
2. CONCRETE: 5,000 PSI AT 28 DAYS
3. REINFORCEMENT  
 - FLAT LID: #5 BAR @ 6" C.C. E.W. (GRADE 60)
4. HALLIDAY S2S 120" X 60" HATCH SUPPLIED BY ICAST TO BE CAST INTO FLAT LID
5. JOINT SEALANT: CONSEAL CS-102

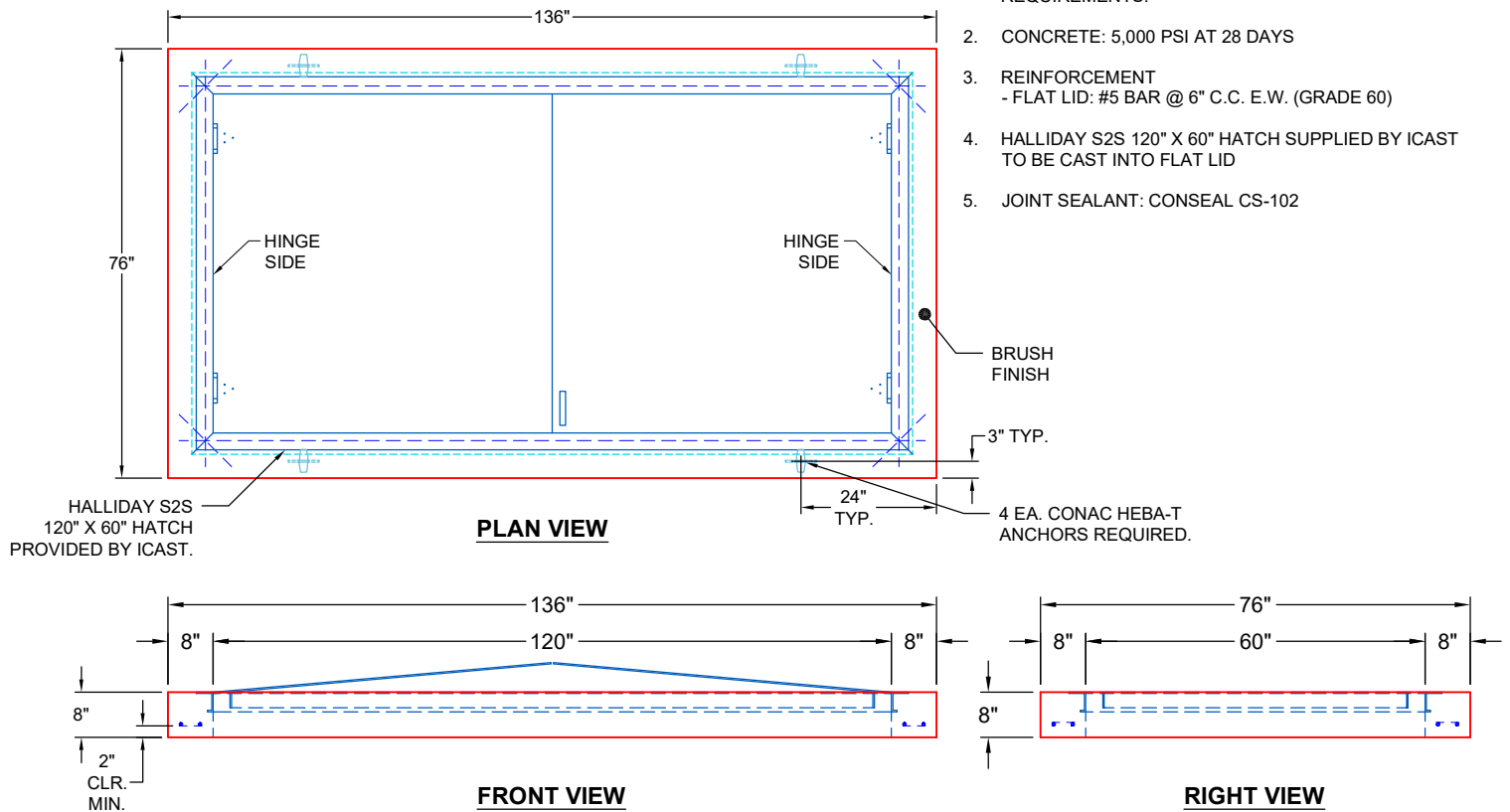

Coating (Int): Coating (Ext):	Seam Up: Flat Seam Dn: Flat	Wall Thickness: 8"	Height (Ext): 8"	Weight (Net): 2105 lb Volume (Net): 0.54cu.yd
----------------------------------	--------------------------------	--------------------	------------------	--

Job Name: 25-3531 - Crescent Hill Filtration Plant Carbon Storage  
 Job Location: Louisville, KY  
 Contractor: Dugan & Meyers, LLC

Plant: Beaver Dam, KY  
 3/30/2026 9:45:22 AM

Tech: K. Cardwell  
 PC: J. Jarvis



**Structure ID: V-008**

**P4 BX60120-08LD08-S**

**BX FLAT TOP 8"W w/60"x120" HATCH**

- P5) 60" x 120" - HATCH (CAST FLUSH) - 3"
- P4) 60" x 120" - BX FLAT TOP 8"W w/60"x120" HATCH - 8"
- P3) 60" x 120" - BOX RISER 8inW, Variable Ht - 38"
- P2) 60" x 120" - BOX RISER 8inW, Variable Ht - 47"
- P1) 60" x 120" - BX Separate Base Slab - 8"
- 1) HATCH (Alum.) - HALLIDAY H2R 48"x48"
- 1) This Structure Includes a Cast-In Item (Hatch)
- 4) 60" x 120" - Conseal CS-102 1.00"
- 1) DOGHOUSE - 44"x44"
- 2) Hole - 6.5
- 1) Hole - 11
- 8) MH Step ML-10-TDS-NCR - 10"

100 lb  
 2105 lb  
 9891 lb  
 11241 lb  
 6085 lb  
 235 lb  
 0 lb  
 0 lb  
 0 lb  
 0 lb  
 0 lb  
 0 lb

**Structure Notes:**  
 1. PER ASTM C913 SPECIFICATIONS.  
 2. CONCRETE = 4,000 PSI AT 28 DAYS.  
 3. NO INVERT CHANNEL.  
 REINFORCING PER ASTM A615 (GRADE 60).  
 - TOP SLAB (As .62) #5 BARS AT 6" C.C.E.W.  
 - WALLS (As .31) #5 BARS AT 12" C.C.E.W.  
 - FLOOR (As .31) #5 BARS AT 12" C.C.E.W.

Structure Total: 29658 lb

**GENERAL NOTES:**

1. MANUFACTURED TO ASTM C-913 (LATEST REVISION) & DESIGNED TO MEET ASTM C857 & ACI 318 REQUIREMENTS.
2. CONCRETE: 5,000 PSI AT 28 DAYS
3. REINFORCEMENT  
 - FLAT LID: #5 BAR @ 6" C.C. E.W. (GRADE 60)
4. HALLIDAY S2S 120" X 60" HATCH SUPPLIED BY ICAST TO BE CAST INTO FLAT LID
5. JOINT SEALANT: CONSEAL CS-102

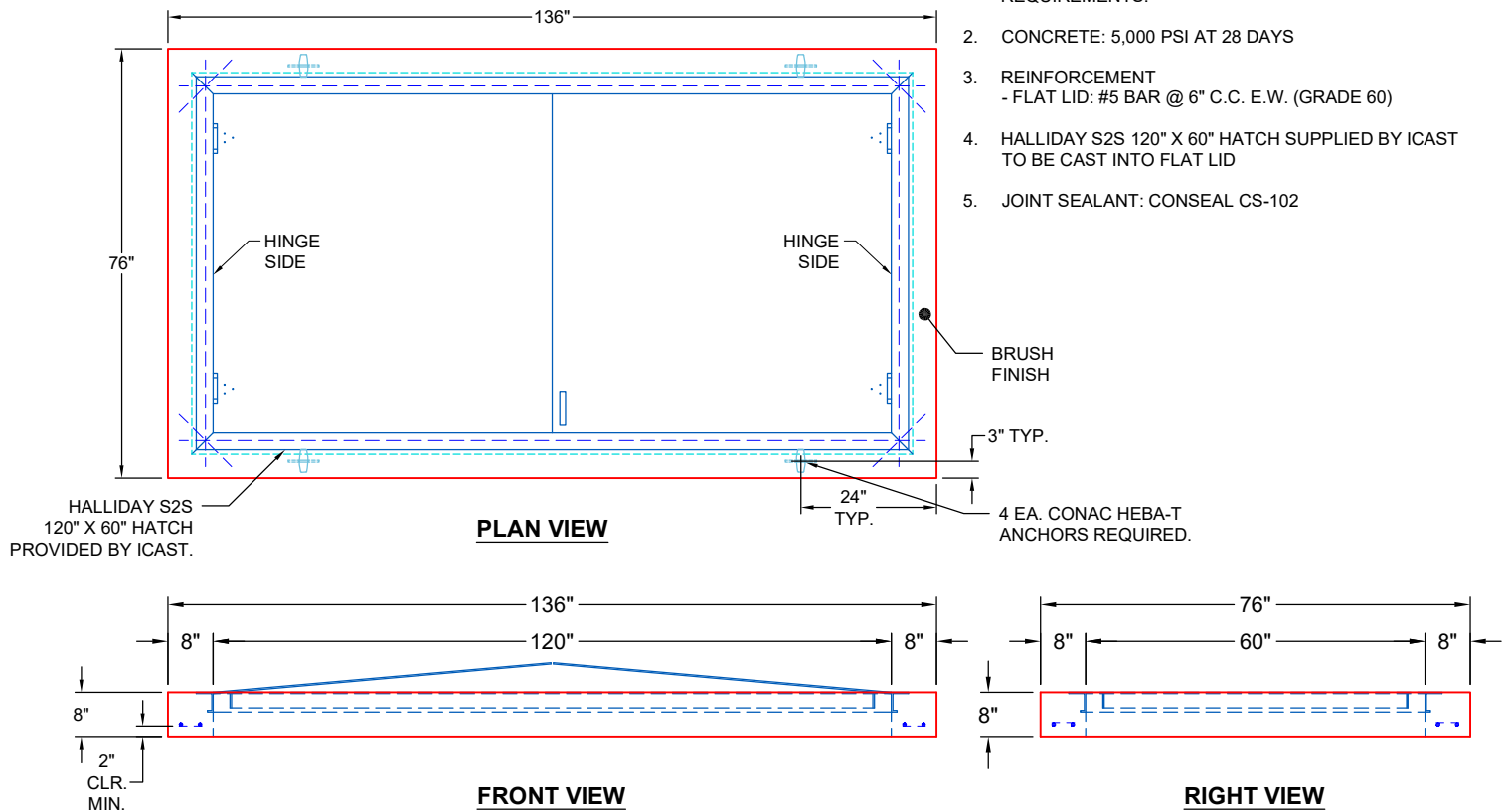

Coating (Int): Coating (Ext):	Seam Up: Flat Seam Dn: Flat	Wall Thickness: 8"	Height (Ext): 8"	Weight (Net): 2105 lb Volume (Net): 0.54cu.yd
----------------------------------	--------------------------------	--------------------	------------------	--

Job Name: 25-3531 - Crescent Hill Filtration Plant Carbon Storage  
 Job Location: Louisville, KY  
 Contractor: Dugan & Meyers, LLC

Plant: Beaver Dam, KY  
 3/30/2026 9:45:22 AM

Tech: K. Cardwell  
 PC: J. Jarvis



**Structure ID: V-007**

**P4 BX060060-08LD08-S**

**CB FLAT TOP 8"W w/48"x48" HATCH**

- P5) 48" x 48" - HATCH (CAST FLUSH) - 3"
- P4) 60" x 60" - CB FLAT TOP 8"W w/48"x48" HATCH - 8"
- P3) 60" x 60" - BOX RISER 8inW, Variable Ht - 71"
- P2) 60" x 60" - BOX RISER 8inW, Variable Ht - 70"
- P1) 60" x 60" - BX Separate Base Slab - 8"
- 1) HATCH (Alum.) - HALLIDAY H2R 48"x48"
- 1) This Structure Includes a Cast-In Item (Hatch)
- 3) 60" x 60" - Conseal CS-102 1.00"
- 1) 48" x 48" - Conseal CS-102 1.00"
- 1) DOGHOUSE - 44"x44"
- 2) Hole - 6.5
- 13) MH Step ML-10-TDS-NCR - 10"

100 lb	<b>Structure Notes:</b> 1. PER ASTM C913 SPECIFICATIONS. 2. CONCRETE = 4,000 PSI AT 28 DAYS. 3. NO INVERT CHANNEL.  REINFORCING PER ASTM A615 (GRADE 60). - TOP SLAB (As .62) #5 BARS AT 6" C.C.E.W. - WALLS (As .31) #5 BARS AT 12" C.C.E.W. - FLOOR (As .31) #5 BARS AT 12" C.C.E.W.
2331 lb	
12964 lb	
11518 lb	
3877 lb	
235 lb	
0 lb	
0 lb	
0 lb	
0 lb	
0 lb	
0 lb	
0 lb	
Structure Total:	31025 lb

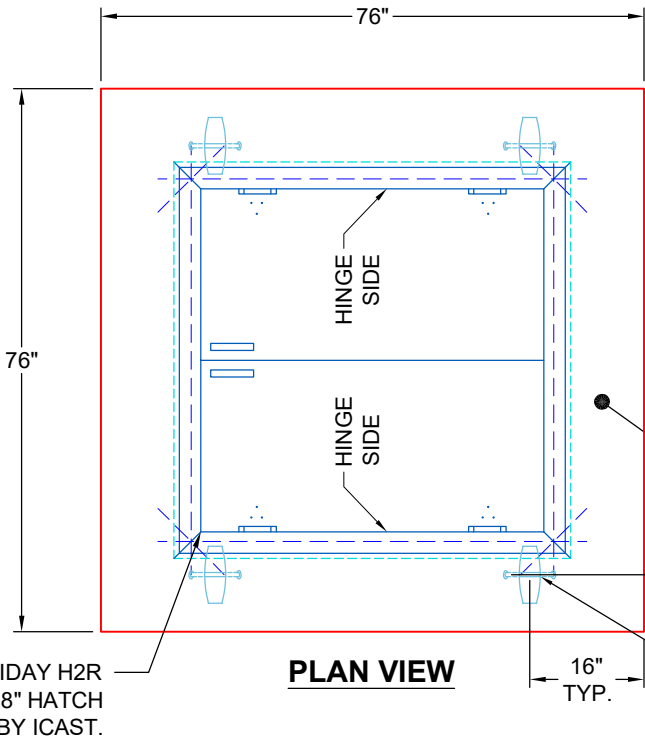

- GENERAL NOTES:**
1. MANUFACTURED TO ASTM C-913 (LATEST REVISION) & DESIGNED TO MEET ASTM C857 & ACI 318 REQUIREMENTS.
  2. CONCRETE: 5,000 PSI AT 28 DAYS
  3. REINFORCEMENT  
- FLAT LID: #5 BAR @ 6" C.C. E.W. (GRADE 60)
  4. HALLIDAY H2R 48" X 48" HATCH SUPPLIED BY ICAST. CAST- IN
  5. JOINT SEALANT: CONSEAL CS-102

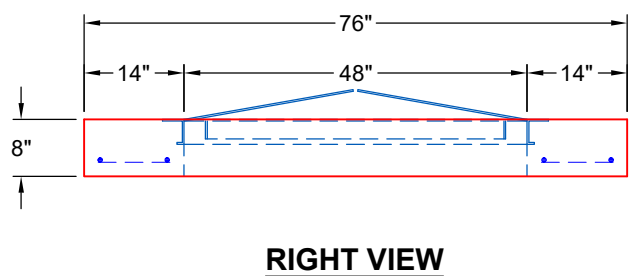
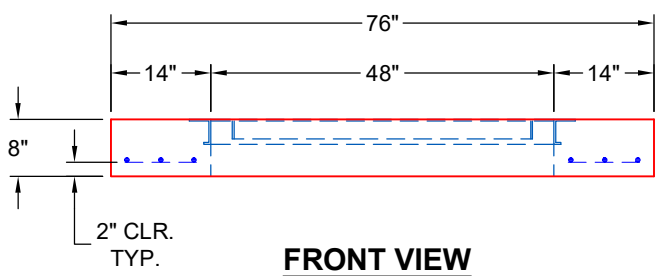

Coating (Int): Coating (Ext):	Seam Up: Flat Seam Dn: Flat	Wall Thickness: 8"	Height (Ext): 8"	Weight (Net): 2331 lb Volume (Net): 0.6cu.yd
----------------------------------	--------------------------------	--------------------	------------------	---