

Job Name: 25-2898 - Hunter's Ridge Ph.1
 Job Location: Owensboro, KY
 Contractor: Ernie Davis & Sons Mechanical, Inc.

Plant: 100
 5/29/2026 8:45:52 AM

Tech: Jared - A
 PC: A. Chambers



Structure ID: AA-4 - AF-1

P2 MH048LD07-24X36RECT

MH FLAT TOP w/24"x36" Hole F/F

- P3) 24" x 36" - CASTING HEIGHT - 6"
- P2) 48" - MH FLAT TOP w/24"x36" Hole F/F - 7"
- P1) 48" - MH BASE F/n - 42"
- 1) 48" - Conseal CS-102 1.00"
- 1) 24" x 36" - Conseal CS-102 1.00"
- 2) Hole - 32
- 1) Hole - 26
- 3) MH Step ML-10-TDS-NCR - 10"

0 lb
 1044 lb
 3304 lb
 0 lb
 0 lb
 0 lb
 0 lb
 0 lb

 4349 lb

Structure Total:

- Structures Notes:
1. PER ASTM C-478 SPECIFICATIONS
 2. CONCRETE: 4,000 PSI AT 28 DAYS
 3. REINFORCEMENT: #4 BAR @ 10" C.C. E.W. (GRADE 60) - 2" MIN. REBAR CLEARANCE (TYP)
 4. HOE-525 FRAME, GRATE, & CURB HOOD SUPPLIED BY OTHERS
 5. LIFTERS: 4 EA. WRA016 CONAC WIRE ROPE ANCHORS FOR PLANT & FIELD HANDLING
 6. TOP SURFACE TO RECEIVE FLOATED FINISH

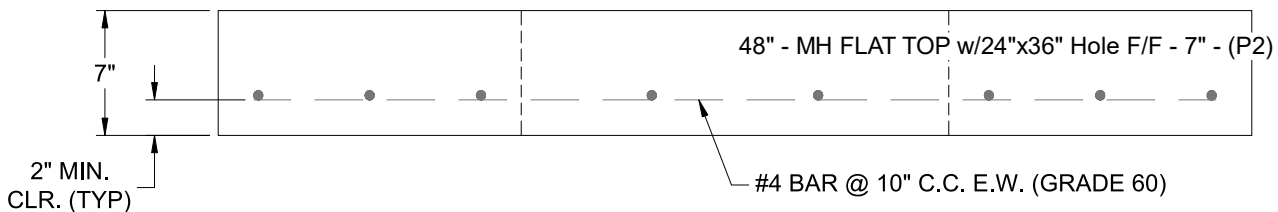
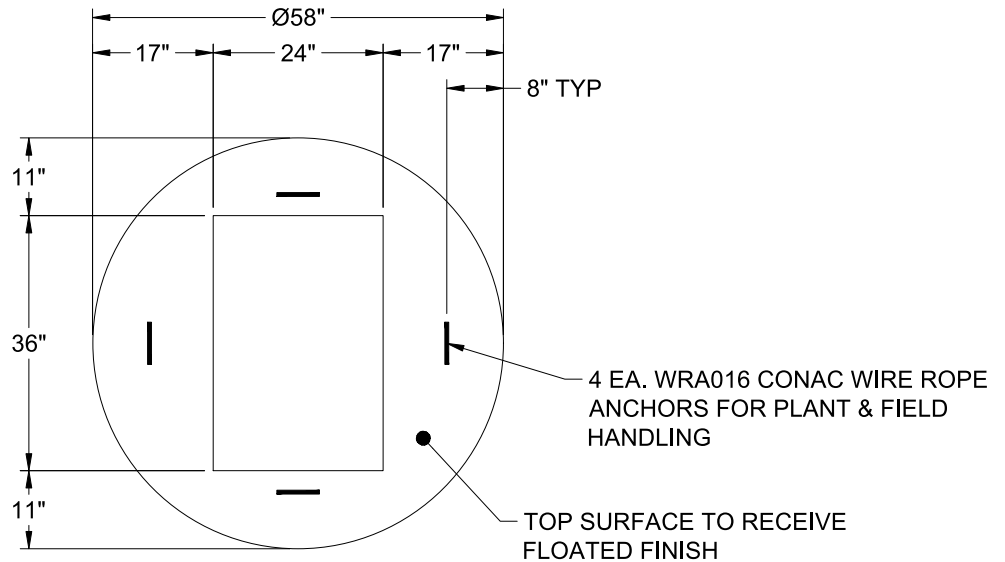

Coating (Int): Coating (Ext):	Seam Up: Flat Seam Dn: Flat	Wall Thickness: 5"	Height (Ext): 7"	Weight (Net): 1044 lb Volume (Net): 0.27cu.yd
----------------------------------	--------------------------------	--------------------	------------------	--