

**Structure ID: AA-3 - AB-1**

**P1 MH072BAVF**

**MH BASE Custom Ht F/n**

P3) 24" x 70" - CASTING HEIGHT - 6" P2) 72" - MH FLAT TOP w/24"x70" Hole F/F - 10" P1) 72" - MH BASE Custom Ht F/n - 75" 1) 72" - Conseal CS-102 1.00" 1) Hole - 48 1) Hole - 22 1) Hole - 34 6) MH Step ML-10-TDS-NCR - 10"	<table style="width:100%; border-collapse: collapse;"> <tr><td style="text-align: right;">0 lb</td><td></td></tr> <tr><td style="text-align: right;">3465 lb</td><td></td></tr> <tr><td style="text-align: right;">12909 lb</td><td></td></tr> <tr><td style="text-align: right;">0 lb</td><td></td></tr> <tr><td style="text-align: right;">0 lb</td><td></td></tr> <tr><td style="text-align: right;">0 lb</td><td></td></tr> <tr><td style="text-align: right;">0 lb</td><td></td></tr> <tr><td style="text-align: right;">0 lb</td><td></td></tr> <tr><td style="text-align: right;">0 lb</td><td></td></tr> <tr><td style="text-align: right;">-----</td><td></td></tr> <tr><td style="text-align: right;">16374 lb</td><td></td></tr> </table> <p style="text-align: right;">Structure Total: 16374 lb</p>	0 lb		3465 lb		12909 lb		0 lb		0 lb		0 lb		0 lb		0 lb		0 lb		-----		16374 lb	
0 lb																							
3465 lb																							
12909 lb																							
0 lb																							
0 lb																							
0 lb																							
0 lb																							
0 lb																							
0 lb																							
-----																							
16374 lb																							

**Structures Notes:**

1. PER ASTM C-478 SPECIFICATIONS
2. CONCRETE: 4,000 PSI AT 28 DAYS
3. REINFORCEMENT: PER ASTM A615
4. NO STORM INVERT
5. STEPS AT 255 DEGREES
6. HOE-525 DOUBLE FRAMES, GRATES, & CURB HOODS SUPPLIED BY OTHERS

Rim: 424.8'    Rim to Invert: 7.3'    Slack: 0.6"    Sump: 4"    Step Position: 255°

Position	Elev	Angle	Ext. (cw)	Pipe	Pipe OD	Connector	Hole	Horz Size	Up ( )	Offset
Invert 1	417.5'	0°	0"	36" RCP B WALL	44"	Hole 48	48"	52.54"	0"	0"
Invert 2	421'	63°	47.25"	15" RCP B WALL	19.5"	Hole 22	22"	22.358"	43.75"	0"
Invert 3	418.5'	150°	112.625"	24" RCP B WALL	30"	Hole 34	34"	35.41"	13"	0"
Invert 4										
Invert 5										
Invert 6										
Invert 7										
Invert 8										

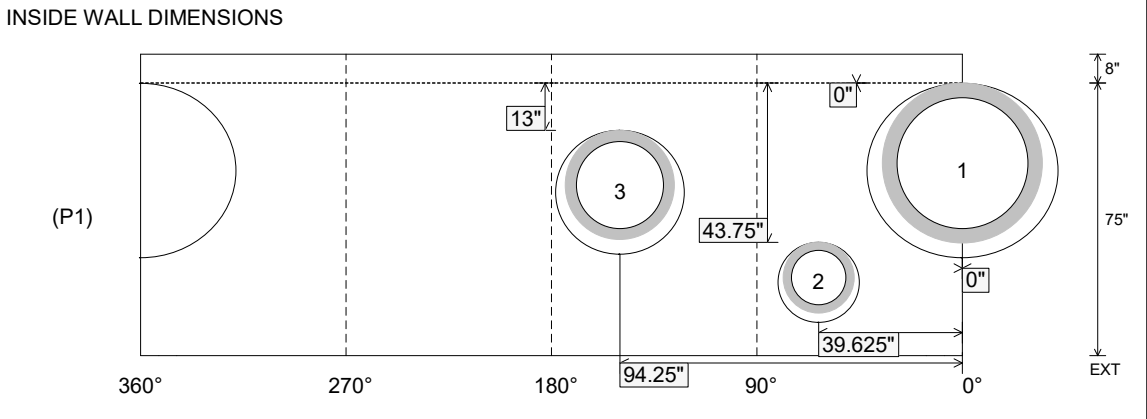
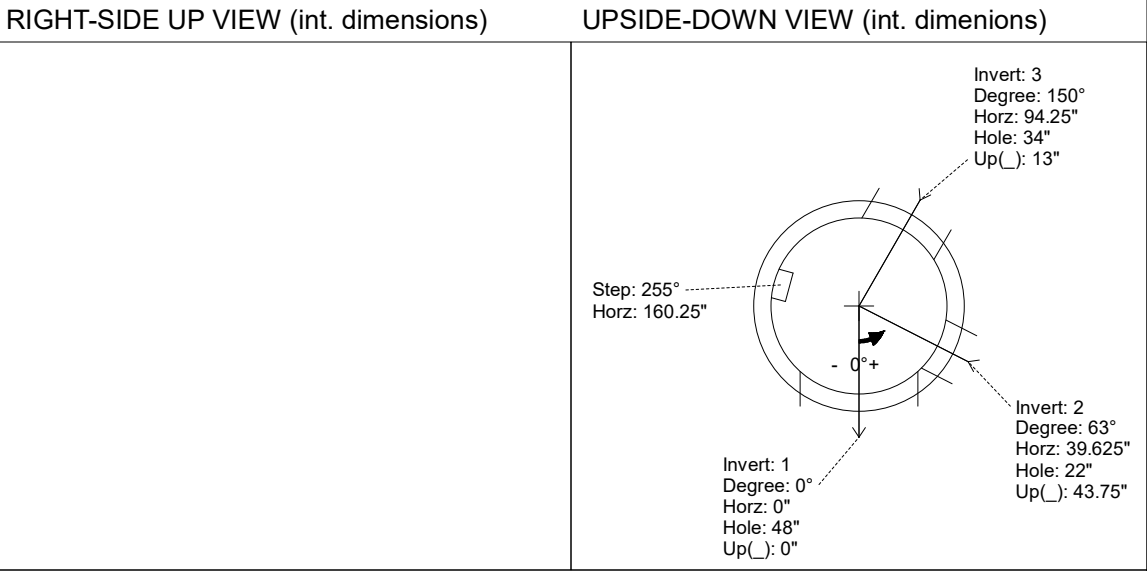

Coating (Int): Coating (Ext):	Seam Up: Flat Seam Dn: n/a	Wall Thickness: 7" Floor Height: 8"	Height (Int): 75" Height (Ext): 83"	Weight (Net): 12909 lb Volume (Net): 3.3cu.yd
----------------------------------	-------------------------------	--	--	--